

RIA-76-U55  
Part II

# ARO Report 75-2

## PROCEEDINGS OF THE TWENTIETH CONFERENCE ON THE DESIGN OF EXPERIMENTS IN ARMY RESEARCH DEVELOPMENT AND TESTING PART 2

19971103 136



TECHNICAL  
LIBRARY

Approved for public release; distribution unlimited.  
The findings in this report are not to be construed  
as an official Department of the Army position, un-  
less so designated by other authorized documents.

DTIC QUALITY INSPECTED 3

Sponsored by  
The Army Mathematics Steering Committee  
on Behalf of

THE CHIEF OF RESEARCH, DEVELOPMENT AND ACQUISITION

U. S. Army Research Office

Report No. 75-2  
June 1975

PROCEEDINGS OF THE TWENTIETH CONFERENCE  
ON THE DESIGN OF EXPERIMENTS

Part 2

Sponsored by the Army Mathematics Steering Committee

HOSTS

U. S. Army Operational Test and Evaluation Agency

and

U. S. Army Engineer Center at Fort Belvoir

23-25 October 1974

Approved for public release; distribution unlimited.  
The findings in this report are not to be construed  
as an official Department of the Army position,  
unless so designated by other authorized documents.

U. S. Army Research Office  
P. O. Box 12211  
Research Triangle Park, North Carolina

**DTIC QUALITY INSPECTED 3**

TABLE OF CONTENTS

Parts 1 and 2

(Part 2 starts on page 463)

Title	Page
Foreword . . . . .	iii
Table of Contents . . . . .	v
Program . . . . .	ix
Samuel S. Wilks and the Army Experiment Design Conference Series Churchill Eisenhart . . . . .	1
The Information in Contingency Tables Solomon Kullback . . . . .	49
Multi-Dimensional, Non-Gaussian, Random Processes with Specified Covariance and Probability Density Functions James W. Wright . . . . .	55
Design of Experiments for the Evaluation of Materiel Performance in Worldwide Environments Bob O. Benn . . . . .	81
Short Pulse Testing of EEDs and the Bruceton Problem Ramie H. Thompson and Burton V. Frank . . . . .	107
Target Visibility and Decision Optimization Timothy M. Small . . . . .	127
Optimizing a Production Line for Cost and Quantity Eileen M. R. Weigand . . . . .	143
An Application of the Weibull-Gnedenko Distribution Function for Generalizing Conditional Kill Probabilities of Single Fragment Impacts on Target Components William P. Johnson . . . . .	155
Decision Theory Approach to Grading Binomial Populations Paul Williams . . . . .	171
Pseudo-Bayesian Intervals for Reliability of a Series System Given Weibull Component Data Ronald L. Racicot . . . . .	181
The Unique Application of Bayesian Statistics to High Reliability Testing Charles A. Pleckaitis and Erwin Biser . . . . .	195
Robustness Studies for Bayesian Developments in Reliability Chris P. Tsokos and A.N.V. Rao . . . . .	273

A Bayesian Approach to Reliability Growth Analysis John G. Mardo . . . . .	303
Experimental Collection of Statistics by Computer Simulation: The Autovon Network Egon Marx . . . . .	323
An Analysis of Buffers in a Production System Anton Hauschild . . . . .	331
Statistical Model for Controller Performance Measures for an Air Traffic Automated System (ATMAC) Erwin Biser . . . . .	339
A Flexible, General Purpose Covariance Computer Program Clifford J. Maloney and Lucille A. Carver . . . . .	403
Computation of Moments of a Log Rayleigh Distributed Random Variable William L. Shepherd . . . . .	441
Type II Error of the 2x2 Contingency Table Chi-Square Statistic Robert L. Launer . . . . .	449
Daniel Awarded the 1974 Samuel S. Wilks Memorial Medal Frank E. Grubbs . . . . .	459
Progress to Date on Computing Regression Based Estimates of Climatic Changes Following Volcanic Eruptions John Bart Wilburn . . . . .	463
Principal Component Regression Analysis John Bart Wilburn . . . . .	487
Predicting Metastasis of Eucleated Small Ophthalmic Melanomas by Discriminant Function Walter D. Foster . . . . .	525
Forecasting Models for Mosquito Population Behavior Stephen Smeach and Chris P. Tsokos . . . . .	531
Curve Fitting of Discrete Points by Legendre Polynomials Oskar M. Essenwanger . . . . .	543
Fire Control Sensitivity Analysis Using a Programmable Calculator Thomas O. McIntire . . . . .	561
Applications of Sequential Sensitivity Test Strategies and Estimation Using a Weibull Response Function for Extreme Probabilities and Percentage Points Gertrude Weintraub . . . . .	579

Statistical Analysis and Modeling of Sensitivity Augmentation in Cutaneous Communications R. D'Accardi and H. S. Bennett . . . . .	601
Multivariate Data Analysis Herbert Solomon . . . . .	609
Skip-Lct Procedure Formulation Using the Simplified Markov Chain Method Richard M. Brugger . . . . .	647
Semi Markov Chains Applied to Markov Chain Models of Continuous Sampling Plans David L. Arp . . . . .	657
Tracking Reliability Growth Larry H. Crow . . . . .	741
Minimum Variance Solution of a Polynomial Function of Two Noisy Random Variables Oren N. Dalton . . . . .	755
The Probability of Motor Case Rupture Ronald S. Downs and Paul C. Cox . . . . .	801
On the Nonexistence of Some Incomplete Block Designs Alan W. Benton . . . . .	825
Some Uses of Order Statistics H. A. David . . . . .	833
Optimal Resource Allocation for Maximizing System Reliability Gerald J. Lieberman . . . . .	845
Simple Statistical Alternatives to the Method of Least Squares for the Determination of X-Intercept and Slope Joseph F. Hannigan and Mary L. Powers . . . . .	857
A Statistical Approach to Loading and Failure of Structures Ronald G. Merritt . . . . .	875
Strain Gage Instrumentation for Ammunition Testing Paul D. Flynn . . . . .	887
Statistical Investigation into Pulse Charging of Nickel- Cadmium Batteries Walter Kasian and Erwin Biser . . . . .	889
Optical Characterization of Surface Roughness Eugene L. Church and John M. Zavada . . . . .	913
Ranking and Selection Procedures Robert E. Bechhofer. . . . .	929

Maximum Information From Field Experiments  
Marion R. Bryson . . . . . 951

Sample Size Trade-Offs and The Constrained Maximization of  
Information  
William S. Mallios . . . . . 963

Attendees List for the Twentieth Conference on the Design of  
Experiments . . . . . 977

PROGRESS TO DATE ON COMPUTING REGRESSION BASED ESTIMATES  
OF CLIMATIC CHANGES FOLLOWING VOLCANIC ERUPTIONS

John Bart Wilburn  
US Army Electronic Proving Ground  
Fort Huachuca, Arizona 85613

ABSTRACT

Report and invite comments on: Problem addressed, method of analysis, and results to date.

Intent of project is to produce regression based estimates of seasonal temperatures and precipitation at several locations by: Performing a multivariate analysis of Tree Ring data from selected sites in North America and perform a subsequent multivariate regression of the Tree Ring data against meteorological data.

## PURPOSE:

The purpose of this project is to detect tree growth anomalies following volcanic eruptions by analyzing tree ring growth patterns and using modern meteorological data with coincident tree ring data to develop transfer functions for reconstructing climate anomalies following volcanic eruptions.

These climate anomaly patterns can be compared with other derived paleoclimate anomalies for further understanding of the environment.

## PROCEDURE:

The procedure involves several steps of analysis. First the analysis of the tree ring data to detect statistically significant responses of tree sites to volcanic eruptions. The volcanic eruption data was selected from H. H. Lamb (1969), Volcanic Dust in the Atmosphere. (1) The tree ring data were selected from Schulman (1956) (2) and were restricted to Douglas Fir trees with good intercorrelation, high sensitivity, and with sufficient length of sample to incorporate most of the volcanic data. The tree ring data was selected from ten sites (fig. 1) to span a significant portion of the Western North American Continent so as to obtain a good sample of a large scale climatic condition. (29°N - 52°N, 105°W - 121°W).

These tree ring data (percent of normal growth) were then arranged into a 14—year lagged array. That is to 1st column in years 1 (referenced to the beginning of the chronology) to 14. The second columns are years 2 to 15 and so on to the last row of  $M - 13$  to  $M$  for a chronology of  $M$  years. This array is referred to as The Total Ring Data array. From this array, for each site, was extracted a subset referred to as The Ring Signal Data Array.

A second subset is created by implication of the first. That second subset is the remainder of the Total Ring Data and is referred to as The Background Ring Data array. These arrays are denoted by:  $D_{NM}^t$ , Total Ring Array;  $D_{NP}^S$ , Ring Signal Array; and  $D_{NR}^b$ , Background Array.

The  $D^S$  are picked from  $D^t$  in the following manner. The volcanic eruptions are parameterized by date of eruption in years, location in latitude and longitude and magnitude of eruptions denoted by a dust veil index (d.v.i) devised by H. H. Lamb. (pp. 471-473)

A class of eruptions is specified by bounds on these parameters. The dates of the eruptions within these bounds are translated to column numbers of  $D^t$ . These columns of  $D^t$  selected in this manner are extracted from  $D^t$  and comprise the array  $D^S$  of  $N$  rows and the number of columns determined by the number of eruptions in the specified class called for.

The test for significant responses is a two-fold test. First, a CHI—SQUARE test was performed as follows: A CHI—SQUARE test was performed on the row averages of  $D^S$  against the hypothesis of being indistinguishable from the row averages of (a)  $D^t$  and (b)  $D^b$ . At the same time, a CHI—SQUARE test was performed on the row averages of  $D^b$



THE WORLD 1:135,000,000

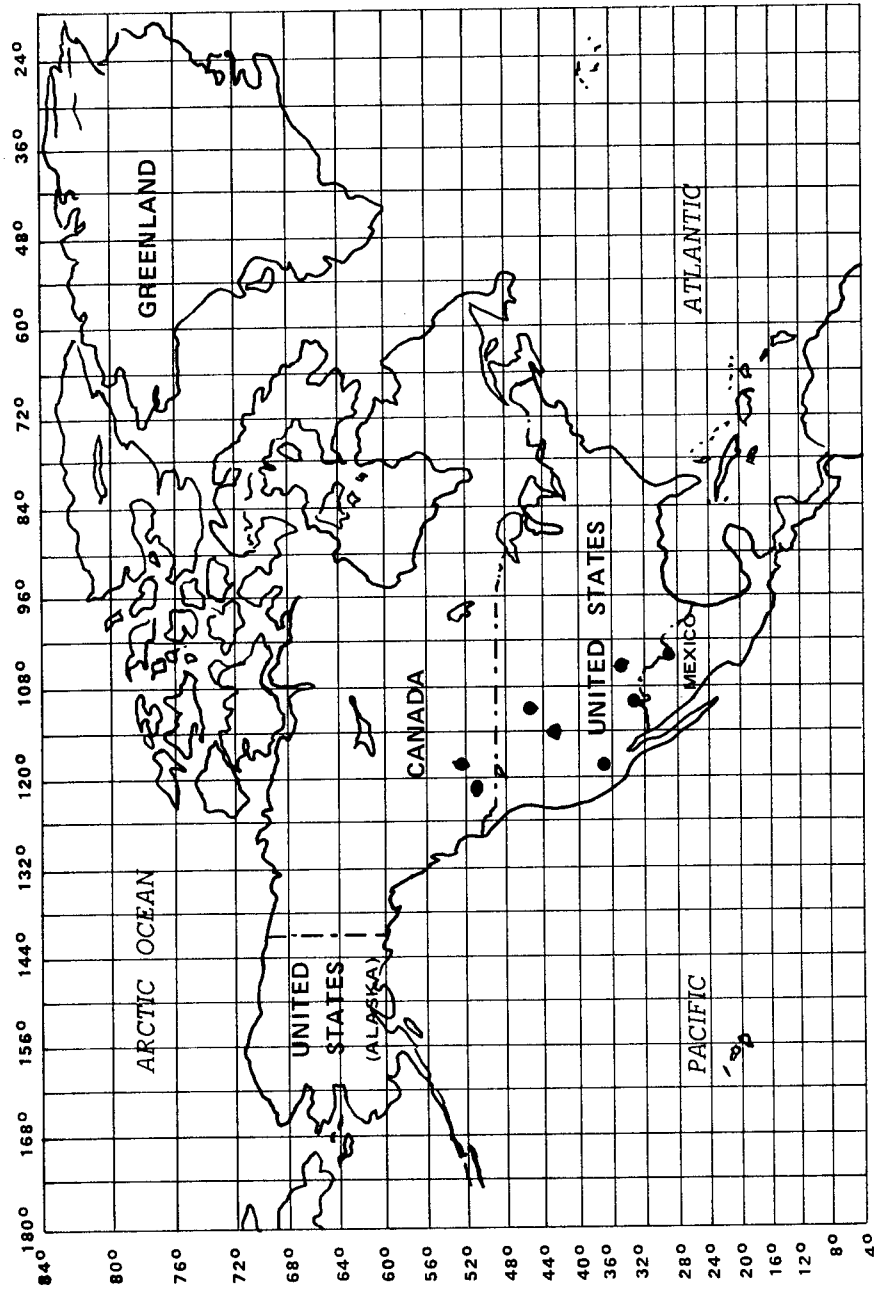


Figure 1

against the hypothesis of being distinguishable from the row average of (c)  $D^t$ , and a CHI-SQUARE test on the row averages of  $D^t$  against the hypothesis of being distinguishable from the average of the total tree ring chronology (d). If all hypothesis are rejected, that is the probability of  $D^S$  being a chance variation of  $D^t$  or  $D^b$  is low while at the same time the probability of  $D^b$  being a chance variation of  $D^t$  is high and that rows of  $D^t$  are all chance variation of the total ring average, then the set  $D^S$  is labeled as a candidate for the second test.

An example of this first test is seen below (fig. 2). The error terms are standard deviations. The example picked is the Tree Ring chronology from the Fraser River Basin. The volcanic criteria was: Magnitude 500 - 5000 d.v.i., latitude  $20^\circ\text{N}$  -  $90^\circ\text{N}$ , longitude  $0^\circ$  to  $135^\circ\text{W}$ .

The second test involved an eigenvector comparison. The software which built the Arrays  $D^t$ ,  $D^S$  and  $D^b$  and computed the CHI-SQUARE test was extended to perform a correlation matrix calculation and an eigenvector extraction. An example of the printout is seen in figure 3 for the correlation matrix  $C^t_{MN} = \frac{1}{M-1} D_{NM} D'_{MN}$ , the eigenvector set  $E^t$  and the eigenvalues  $\Lambda^t$ . This computation was performed for correlation matrices and their associated set of eigenvector/eigenvalues, for variance about the row averages of each of the arrays. That is, the data for  $D^t$ ,  $D^S$  and  $D^b$  were normalized with respect to their own row averages.

There were some interesting developments from these eigenvectors as seen in figures 4, 5, and 6. These vectors are from  $D^t$ , the total ring array. Each eigenvector appears to be a composite of sinusoids of increasing complexity. The first and second vectors being predominately half waves of a fundamental and increasing from there on. The explanation of this behavior is not settled as yet.

Some comments on what is being done as an aid in interpretation are due here. The matrices,  $D^t$ , as well as the others, are correlated by rows.

That is, we are looking at the correlation of a pattern of growth beginning in one year and running sequentially with a pattern of growth beginning in another year and running sequentially. In short, we have a type of autocorrelation. In this context, however, we might explain it as the correlation of a growth sequence with any set of previous growth conditions of each element of the sequence. The eigenvectors depict the relative contribution of the respective rows to the total variance of  $D^t$  accounted for as indicated by the relative magnitude of their associated eigenvalues, or the mode of variance associated with that eigenvalue.

The notion of the mode of variance in years following the year of the first row is particularly useful when we are interpreting the average growth  $\bar{d}^S_j$  and eigenvector of the Ring Signal array  $D^S$ . This is because now we are talking about modes of variance in years following an eruption in a specific class of volcanic eruptions.



## VOLCANIC CRITERIA

MAG. LIMITS		LAT 90					LONG 135						
LOCATION	500	FRASER RIV	TOTAL RING	J = 1	FRASER RIV	TOTAL RING	J = 1	FRASER RIV	TOTAL RING	J = 1	FRASER RIV	TOTAL RING	
		CORRELATION MATRICES											
		J = 1											
1.00	.31	.17	.13	.06	.09	.03	-.02	-.08	-.07	-.03	-.05	-.02	
0.00	1.00	.31	.18	.13	.06	.09	.03	-.02	-.08	-.07	-.03	-.02	
0.00	0.00	1.00	.31	.18	.13	.06	.09	.03	-.02	-.08	-.07	-.03	
0.00	0.00	0.00	1.00	.31	.18	.13	.06	.09	.03	-.02	-.08	-.07	
0.00	0.00	0.00	0.00	1.00	.31	.18	.13	.06	.09	.03	-.02	-.08	
0.00	0.00	0.00	0.00	0.00	1.00	.31	.18	.13	.06	.09	.03	-.02	
0.00	0.00	0.00	0.00	0.00	0.00	1.00	.31	.18	.13	.06	.09	.03	
0.00	0.00	0.00	0.00	0.00	0.00	0.00	1.00	.31	.18	.13	.06	.09	
0.00	0.00	0.00	0.00	0.00	0.00	0.00	0.00	1.00	.31	.18	.13	.06	
0.00	0.00	0.00	0.00	0.00	0.00	0.00	0.00	0.00	1.00	.31	.18	.13	
0.00	0.00	0.00	0.00	0.00	0.00	0.00	0.00	0.00	0.00	1.00	.31	.18	
0.00	0.00	0.00	0.00	0.00	0.00	0.00	0.00	0.00	0.00	0.00	1.00	.31	
0.00	0.00	0.00	0.00	0.00	0.00	0.00	0.00	0.00	0.00	0.00	0.00	1.00	
EIGENVALUES	J = 1												
2.29	.51	.57	2.12	.65	1.36	.67	1.00	.70	.99	.70	.95	.80	.70
EIGENVECTORS													
J = 1													
.07	-.11	-.24	-.27	.33	-.42	.00	.16	.09	.15	-.09	-.44	.49	-.26
.12	.19	.42	-.34	-.23	-.41	-.23	.24	-.15	-.07	-.01	-.25	-.18	.45
.19	-.23	-.37	-.35	-.31	-.28	.08	.01	.08	-.31	.21	.13	-.42	-.35
.25	.27	.23	-.33	.32	-.09	.47	-.35	.09	-.26	-.30	.29	.06	.03
.30	-.31	-.13	-.27	.21	.11	-.43	-.46	-.35	.12	.19	.16	.12	.24
.35	.35	.15	-.18	-.32	.18	-.16	-.15	.45	.47	.16	.00	.10	-.25
.38	-.34	-.10	-.07	-.21	.19	.30	.31	.16	.39	-.50	.05	-.07	.15
.38	.34	-.08	.04	.31	.18	.14	.50	-.33	-.04	.46	.10	.00	-.07
.36	-.34	.15	.15	.18	-.17	.25	.25	.56	-.42	-.03	.01	.08	.15
.32	.31	.17	.24	-.25	.10	-.26	-.15	-.31	-.39	-.40	-.27	.13	-.24
.27	-.27	.24	.31	-.18	-.08	.47	-.31	-.08	-.03	.38	-.42	.09	.06
.21	.22	-.37	.34	.31	-.26	-.03	-.17	.23	.23	-.08	-.17	-.49	.27
.15	-.18	.45	.33	.16	-.41	-.20	.02	-.17	.19	-.11	.31	-.14	-.46
.09	.10	-.26	.27	-.32	-.42	.04	.05	.06	-.01	.09	.48	-.47	.30

AMOUNT OF VARIANCE ACCOUNTED FOR 96 PERCENT    NUMBER OF EIGENVALUES = 13

AVERAGE PRINCIPLE COMPONENTS -- 95 PERCENT PLUS -- (PCEV) XT2

4.08E-14	-2.86E-14	-9.56E-15	5.48E-15
1.03E-15	2.82E-15	2.15E-15	-4.84E-15
		1.29E-15	-1.01E-14

1.07E-14    2.02E-15

Figure 3

TOTAL RING  
Eigen Vector Plot.  
Fraser Riv. Total Ring 0-5000,  $\pm 90^\circ$ Lat,  $\pm 180^\circ$ Long.

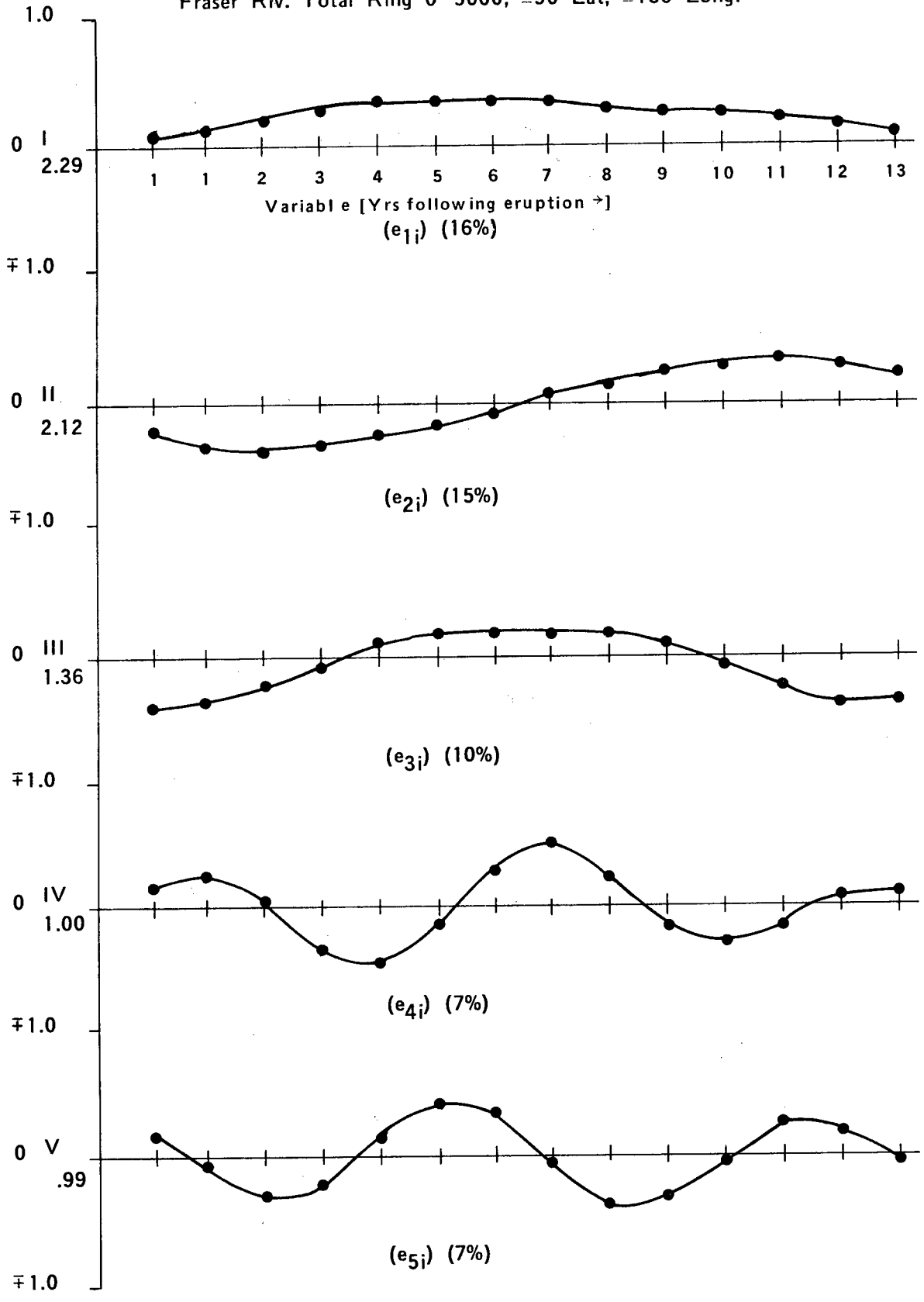


Figure 4

FRASER RIV TOTAL RING (Continued)

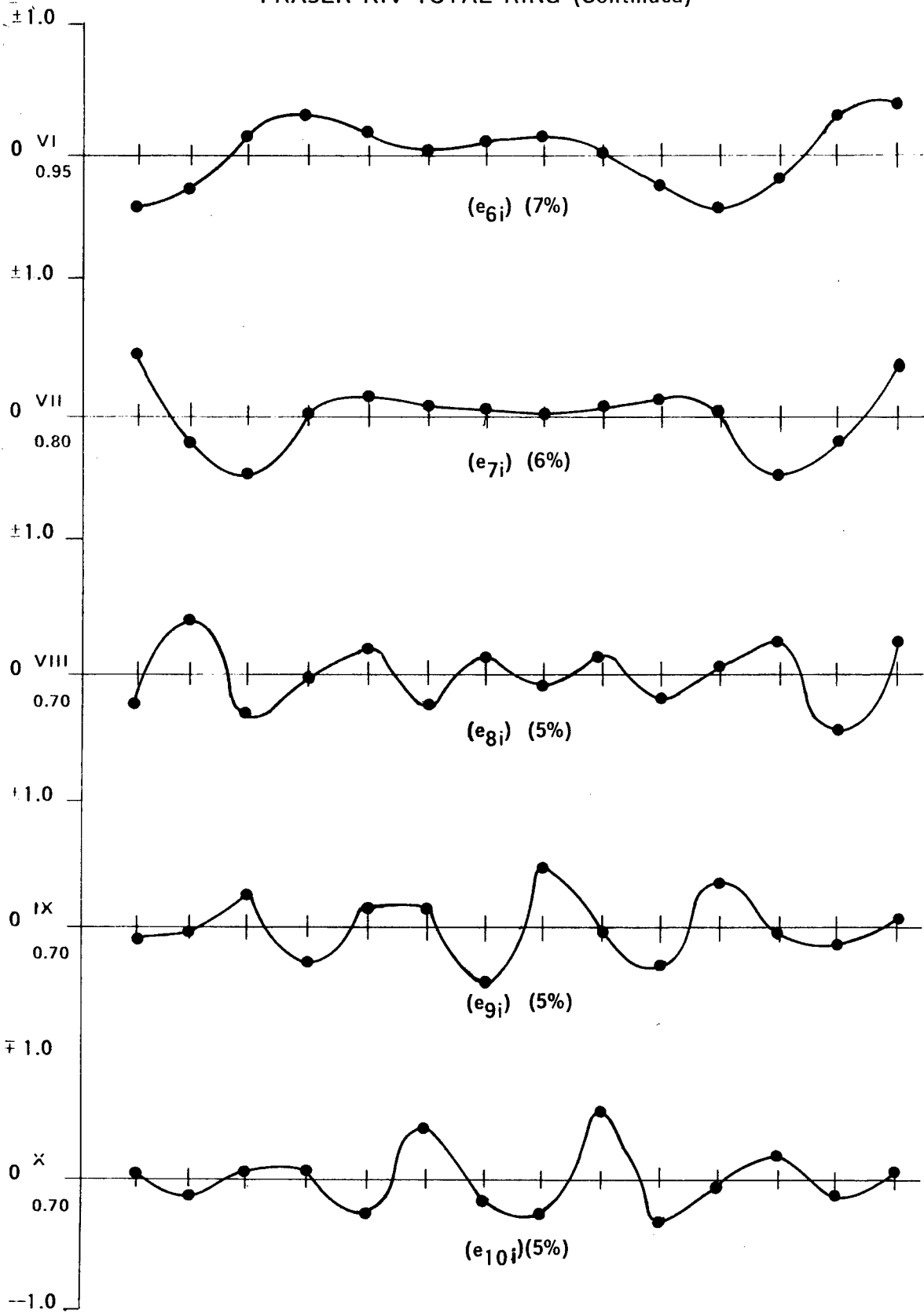


Figure 5

FRASER Riv (Cont'd) Total Ring

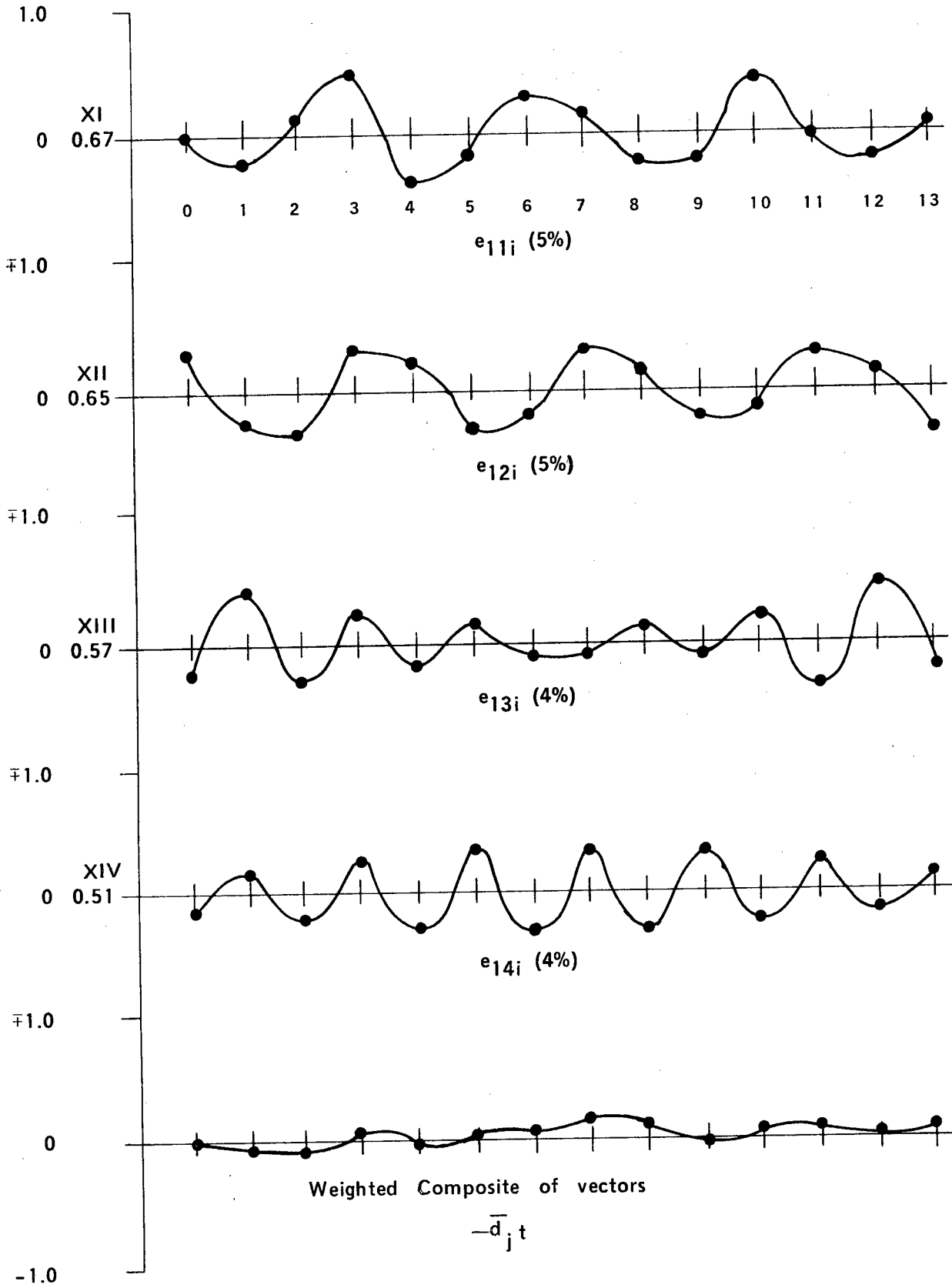


Figure 6

This brings us to the second test for significance - - the comparison of eigenvectors. The Ring Signal arrays  $D^S$  were analyzed a second time. This time the row averages of  $D^t$  were subtracted from the elements of identical rows of  $D^S$  and then a covariance matrix was computed from the new array  $D^S$  and the eigenvectors extracted from the covariance matrix. To insure that we were not comparing unrelated quantities, the eigenvectors of the covariance matrix of  $D^t$ ,  $D^S$  and  $D^b$  were recomputed using their own row averages of their respective arrays as used previously for the correlation matrix computation. The eigenvectors computed from the covariance matrix were nearly identical with those from the correlation matrix. This was to be expected since variances of the row variables are nearly the same.

The rationale behind this move was the following. The eigenvectors extracted from the correlation matrix of  $D^S$  using its own row averages comprise a description of the modes of variance about the response signal of the trees to volcanos, if there is one; whereas, the eigenvectors extracted from the covariance matrix of  $D^S$  using the row averages of  $D^t$  comprise a description of the variance of the response signal of the trees about the background signal of tree growth. Based on this reasoning, if the two sets of eigenvectors are nearly the same, then the array  $D^S$  is labeled as a type I error and rejected. There are more rigorous statistical techniques for comparing the eigenvectors (4) but the situation here does not seem to warrant that degree of rigor. If the two sets of eigenvectors are significantly different, then the array  $D^S$  is labeled as a significant response signal to volcanoes and the eigenvectors of the covariance matrix are considered as the modes of variance of the response. Note that because the variance is indicated by the square of eigenvector component, a mirror image is considered as the same mode.

An example of this comparison is seen in figure 7 which shows the average growth ( $\bar{d}^S_j$ ) of the Fraser River Chronology for 14 years following an eruption specified by the class 500 - 5000 d.v.i., 0 - 135° Long, 20 - 90°N Lat, and the eigenvector,  $E_v$ , extracted from the covariance matrix and the eigenvector,  $E_v$ , extracted from the correlation matrix.

The results of these tests were the selection of four sites, one with two cases, making a total of five cases. The sites and their case were:

Fraser River Basin:	500 — 5000 d.v.i. 20° — 90°W lat. 0° — 135°W long.
Saskatchewan River Basin:	500 — 5000 d.v.i. 20° — 90°N lat. 0° — 135°W long.
Missouri River Basin:	500 — 5000 d.v.i. 20° — 90°N lat. 0° — 135°W long.



FRASER RIVER 500-5000 d.v.i.; 20°N-90°N; 0°-135°W LONG.

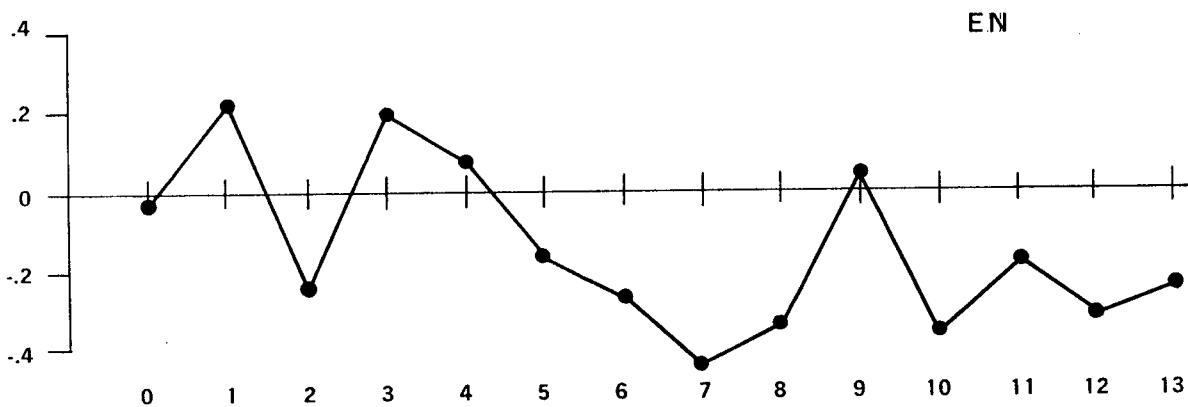
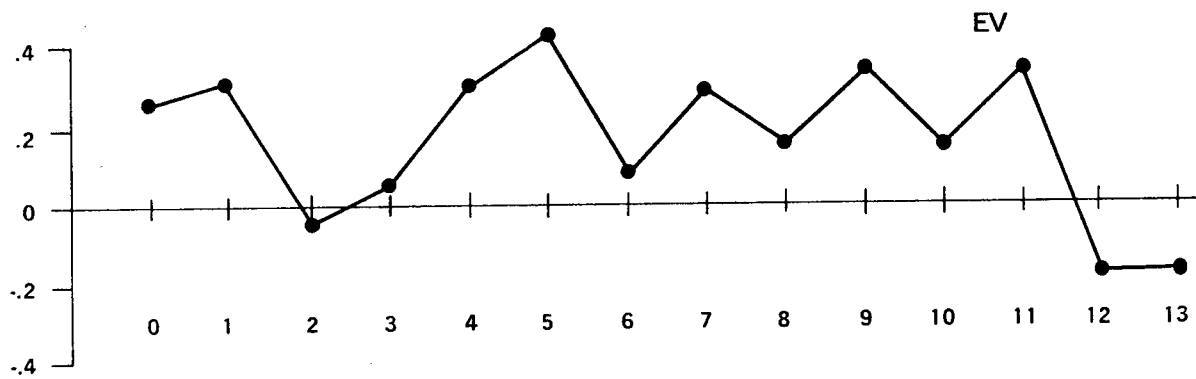
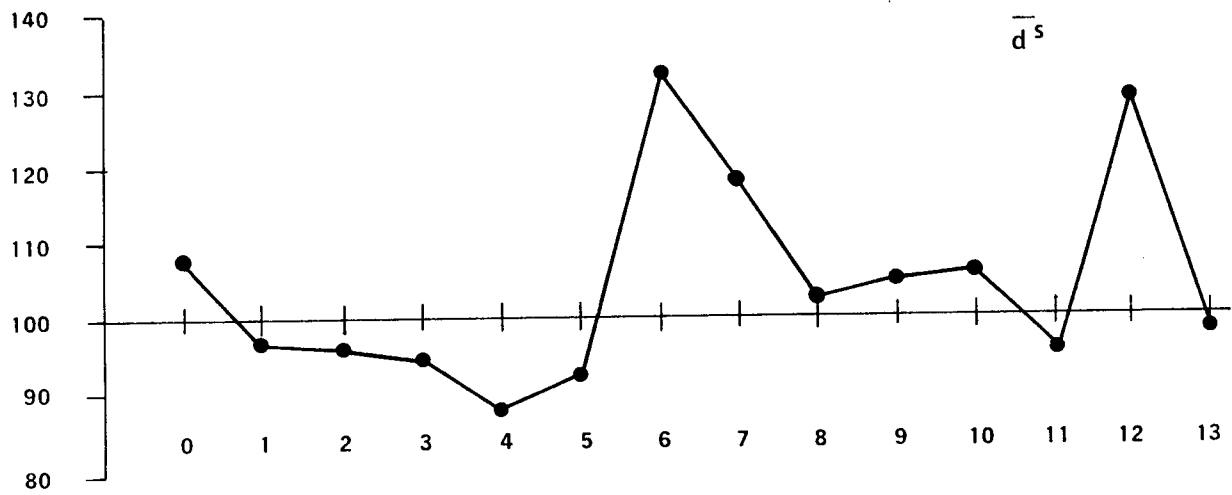


Figure 7

Big Bend:                    500 — 5000 d.v.i.  
                                   20° — 90°N lat.  
                                   0 — 135°W long.

                                  0 — 500 d.v.i.  
                                   ± 20°N lat.  
                                   ± 180°W long.

Note that with four of the cases, a latitudinal dependance may be investigated.

Their average growth curves ( $\bar{d}_j^S$ ) and their first eigenvector (Ev) are shown in figures 8 and 9 respectively. There does not seem to be anything consistent in the growth curves but the eigenvectors indicate a definite similarity of modes of variances between Fraser River and Saskatchewan River and between Missouri River and Big Bend chronologies. One must remember that the growth curves depict the result of change from a previous set of initial conditions of growth and climate, whereas the eigenvectors depict the mode, or mechanism, of that change.

### METHOD

The next part of the project was to use these chronologies from the four sites to estimate the seasonal temperature and precipitation at or near the tree sites during the 14 years following the eruptions. Because of the nature of the tree growth physiology, the seasonal data was referenced to the preceding year. For example, precipitation during the winter season preceding the year of the tree growth (8). The seasons were divided into: (a) preceding year ending 30 May; (b) preceding summer consisting of months June, July, August and September; (c) preceding winter consisting of months October, November, January, and February; and (d) the preceding spring consisting of months March, April, and May.

The regression based estimate was performed by a regression analysis technique referred to as, "Principal Component Regression Analysis." It is described in detail in a paper (5) to be published separately and is included as an appendix in this clinical report.

The essence of the principal component regression analysis is that it allows the physical phenomena, considered as a system, to be partitioned into independent and orthogonal modes of variance, or principal components, and then to allow only those modes of variance of the regressand phenomena which correlate well with all of the allowed modes of variance of the regressor phenomena to be used in the estimate of the regressand. This technique further allows a selective reduction of error in the regressand estimate.

All of the properties mentioned above are consequences of the orthogonality and independence of the principal components of original data.

Quantitatively, the regression rationale is as follows in a brief outline. We have a set of tree ring data  $D_{NM}^t$  from which a complete set  $D_{NU}^t$  can be selected which matches, chronologically, a set of meteorological data  $F_{NU}$  also formatted into a lagged array. The meteorological data is from a station at or near the tree site. From these two sets of data are

# AVERAGE TREE GROWTH

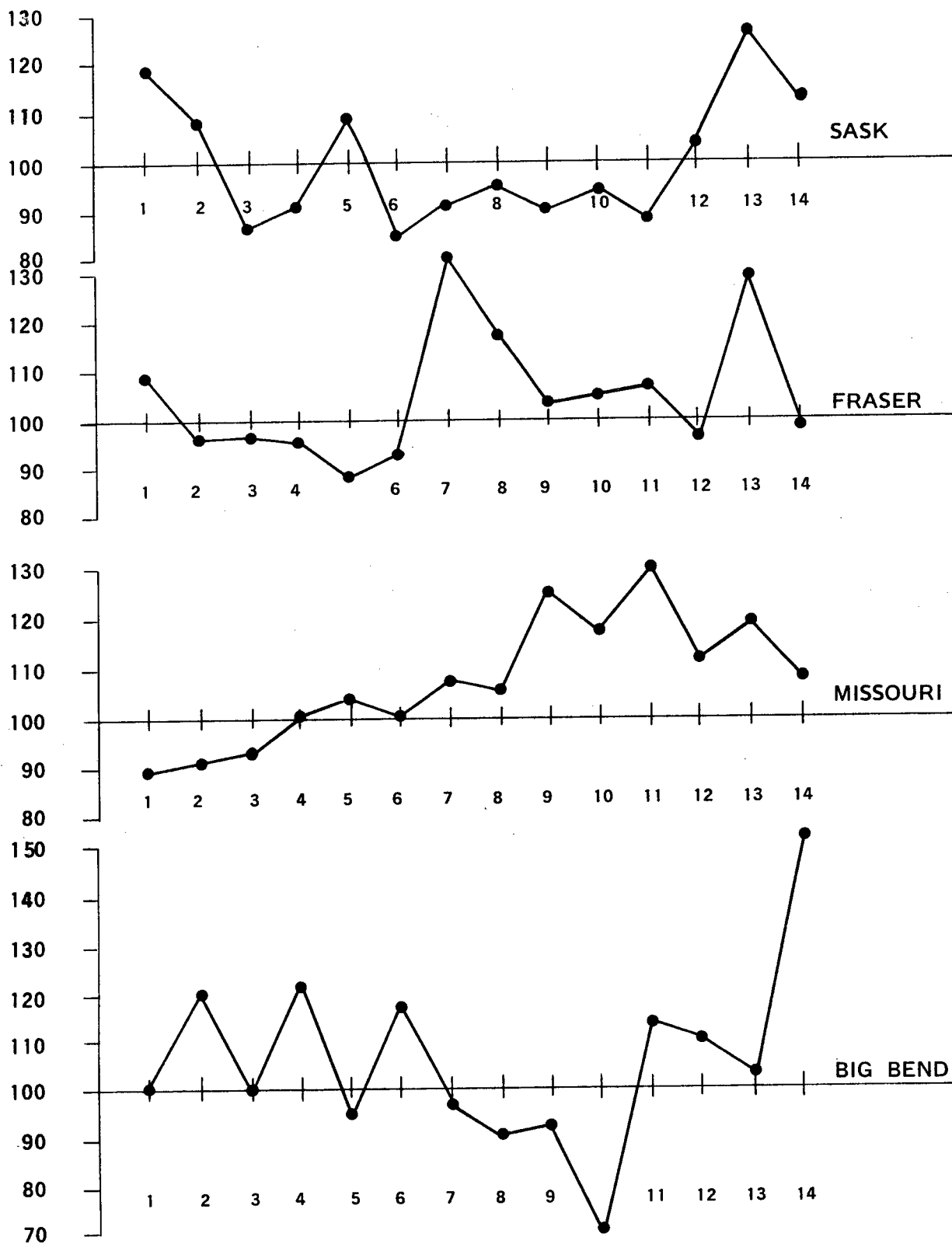


Figure 8

# PLOT OF 1ST EIGENVECTOR $E_V$

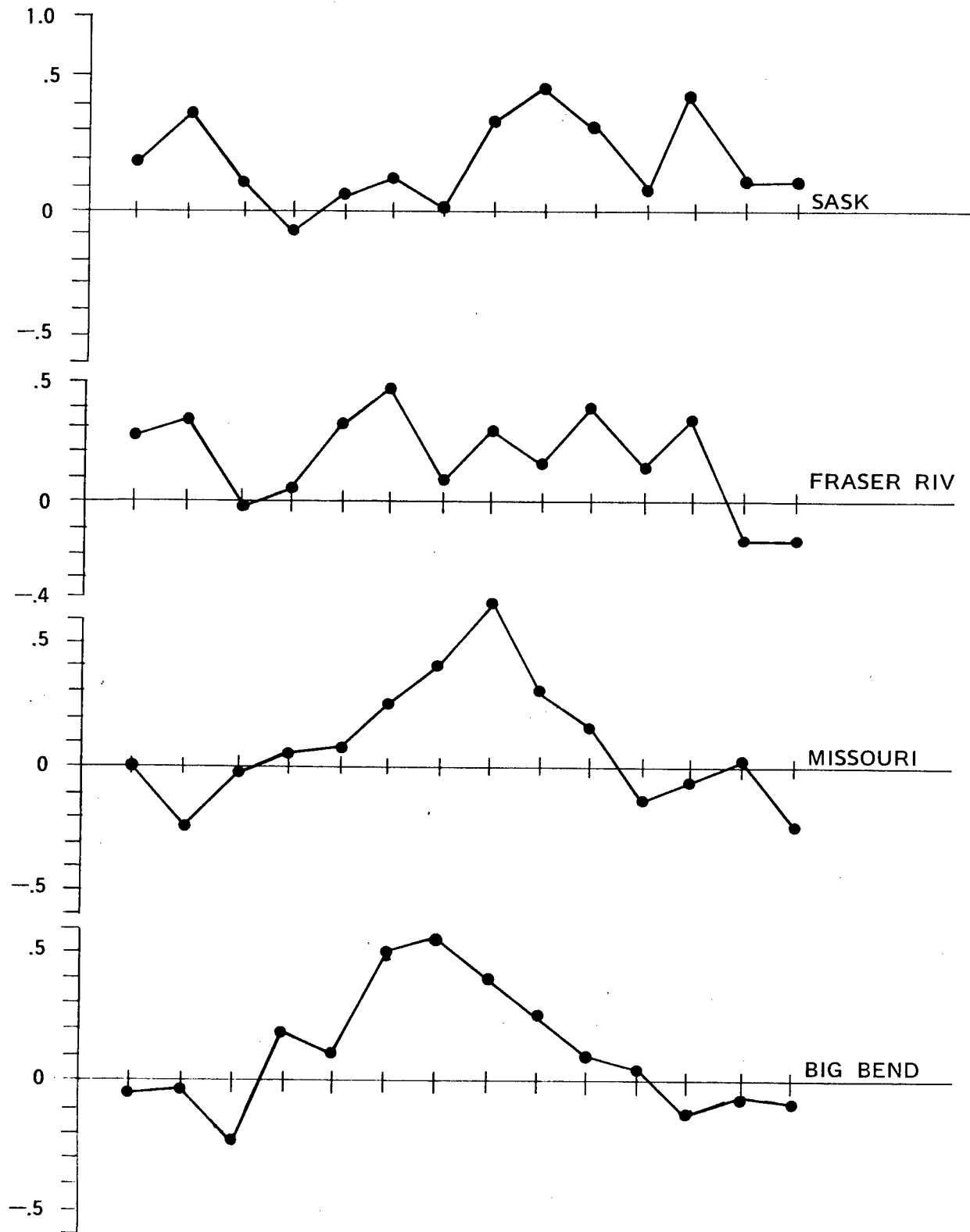


Figure 9

computed the correlation matrices  $C^d_{NN}$  and  $C^f_{NN}$  and subsequently the eigenvector sets are extracted satisfying the equations:

$$C^d_{NN} E_{NN} = E_{NN} \Lambda_{NN}$$

$$C^f_{NN} G_{NN} = G_{NN} \Omega_{NN}$$

The unitary transformation of D and F into their respective principal components is performed by:

$$X_{NU} = E'_{NN} D^t_{NU}$$

$$Y_{NU} = G'_{NU} F_{NU} \quad (1)$$

Now then, from  $X_{NU}$  we select a specified number of components  $q$  accounting for the amount of variance requested. This is determined from the knowledge of the fact that the amount of variance accounted for by the  $i^{\text{th}}$  principal component,  $X_{iU}$ , is given by

$$V_U(X_{iU}) = \frac{\Lambda_i}{\text{tr} \Lambda_{NN}}$$

Thus all have a set  $X_{qU}$  accounting for a specified amount of variance given by:

$$V_U(X_{qU}) = \sum_{i=1}^q \frac{\lambda_i}{\text{tr} \Lambda_{NN}}$$

A set of regression equations  $\hat{\beta}_{Nq}$  are calculated such that we have a regression model of

$$\hat{Y}_{NU} = \hat{\beta}_{Nq} X_{qU} + \epsilon_{NN} \quad (2)$$

It is worth noting that because the  $X_{NU}$  are all independent, the  $q$  coefficients of the  $N^{\text{TH}}$  equation are completely independent. Also, the multiple correlation coefficients,  $R^2_N$  are unambiguous because the joint confidence region of the regression equation is unambiguous. In any case, recalling the transformation (1), (2) can be restated as

$$F_{NP} = G_{NN} \beta_{Nq} E'_{qq} D^S_{qp} \quad (3)$$

Those equations  $\hat{\beta}_{Nq}$  which fail an F-test against the hypothesis  $C \hat{\beta} = 0$  are set to zero. This amounts to a kind of stepwise regression except that the variables rejected are those modes of variance of the system of F which have an insignificant statistical relationship with any combination of all of the modes of variance of the system of D.

The confidence bounds (90%) of the estimate,  $F_{NP}$ , indicated by  $\delta F_{NP}$  are computed from the confidence bounds of  $\beta_{Nq}$  indicated by  $V^K_{qq}$ ;  $K = 1, N$ . The

FLOW CHART OF THE REGRESSION

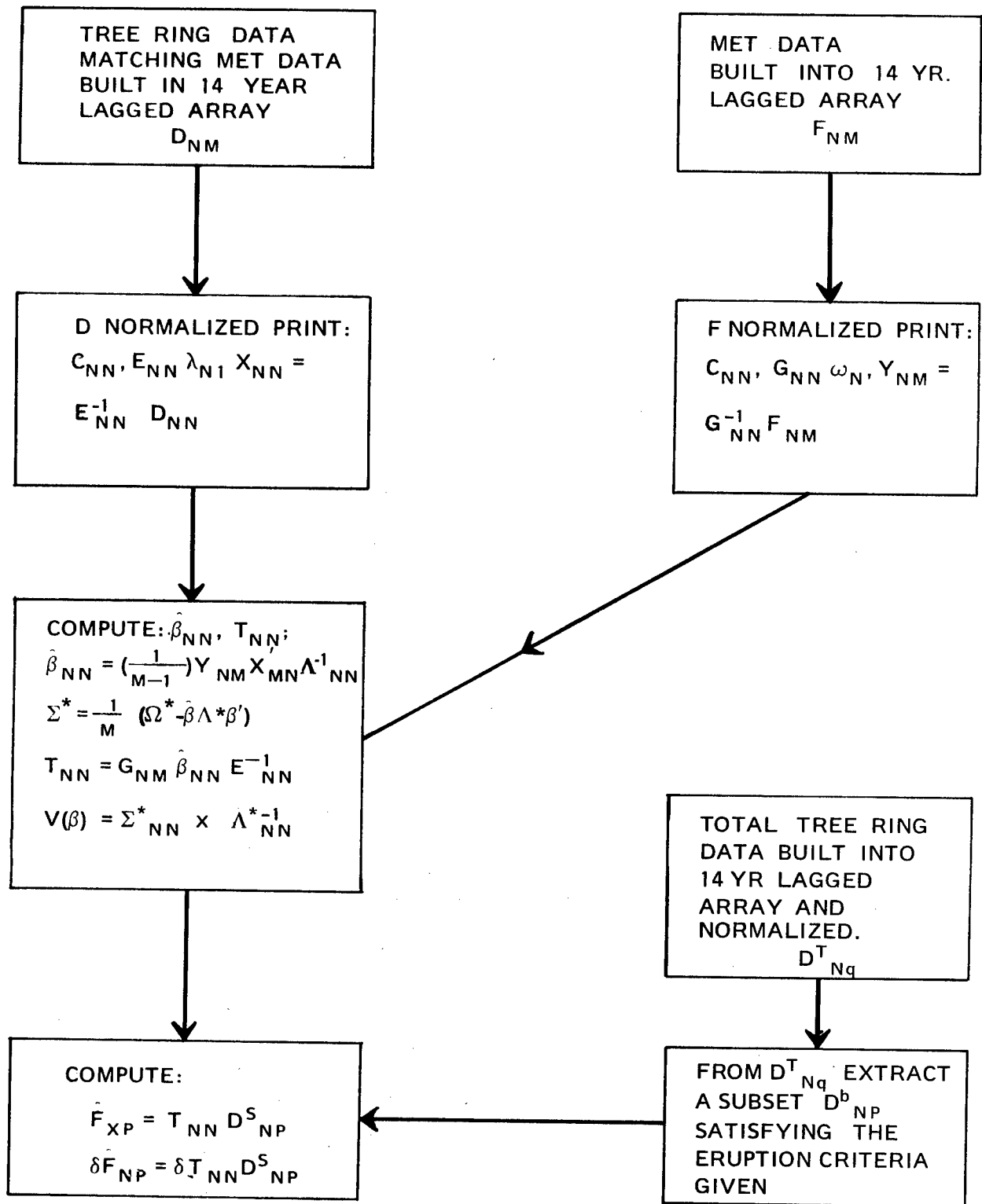


Figure 10

computation is performed by (Cf.5)

$$\delta \hat{F}_{NP} = G_{NN} \left\{ t(p-q-1, 1-\alpha/2) [C_{iq} [D_{PN}^S E_{Nq}' V_{qq}^K E_{qN}' D_{NP}^S]^{1/2}] \right\} \quad (4)$$

Summarizing, the estimation of  $F_{NP}$  from  $D_{NP}^S$  can be performed by transfer function  $T_{NN}$

$$T_{NN} = G_{NN} \beta_{qq} E_{qN}'$$

and the calculation of the confidence bound of the estimate  $F_{NP}$  can be performed by an operator function of  $\delta F_{NP}$  on  $D_{NP}^S$  as indicated in (4).

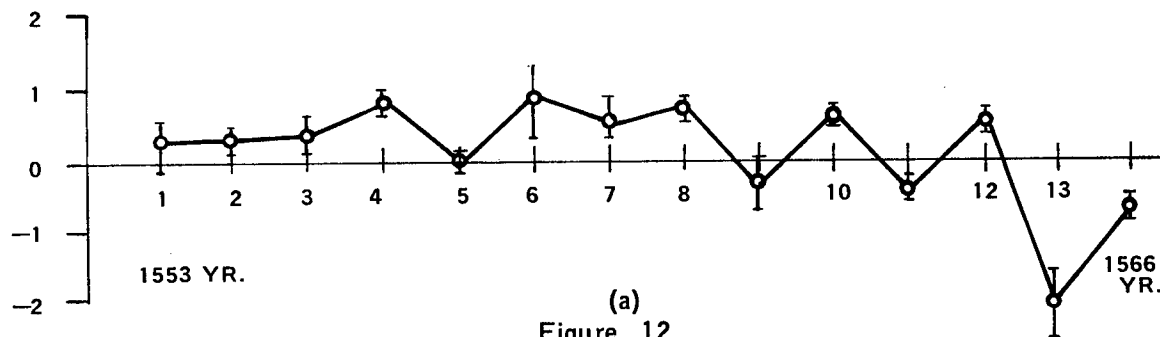
This analysis was implemented in the manner indicated by the flow chart shown in figure 10.

The results to date are for data selected from the Fraser River Chronology for the class of eruptions specified by 500 - 5000 d.v.i.,  $0^\circ$  -  $135^\circ$  W Long,  $20^\circ$  -  $90^\circ$  N Lat. The meteorological data tested was the pre-summer precipitation from Kamloops, Alberta, Canada.

The regression based estimates of the pre-summer precipitation in Kamloops, Canada was made by using the best estimates for each of the 14 years selected from the regressions specifying: 80 percent, 90 percent, 95 percent and 100 percent of the variance of the Tree Ring data system and accepting the regression equations which pass the 90 percent confidence F-test.

Figure 11 (Plate 10) of Appendix A is an example printout of the principal component regression computer program run of a CDC 6500 for the case of 80 percent variance requested. Note the program computes the estimate twice; once before the F-test rejection and then again incorporating the F-test rejection.

Figure 12 illustrates the estimates of the pre-summer precipitation. These estimates are the composite of the best results of all four cases (80%, 90%, 95% and 100% of Tree Ring data variance).



(a)  
Figure 12

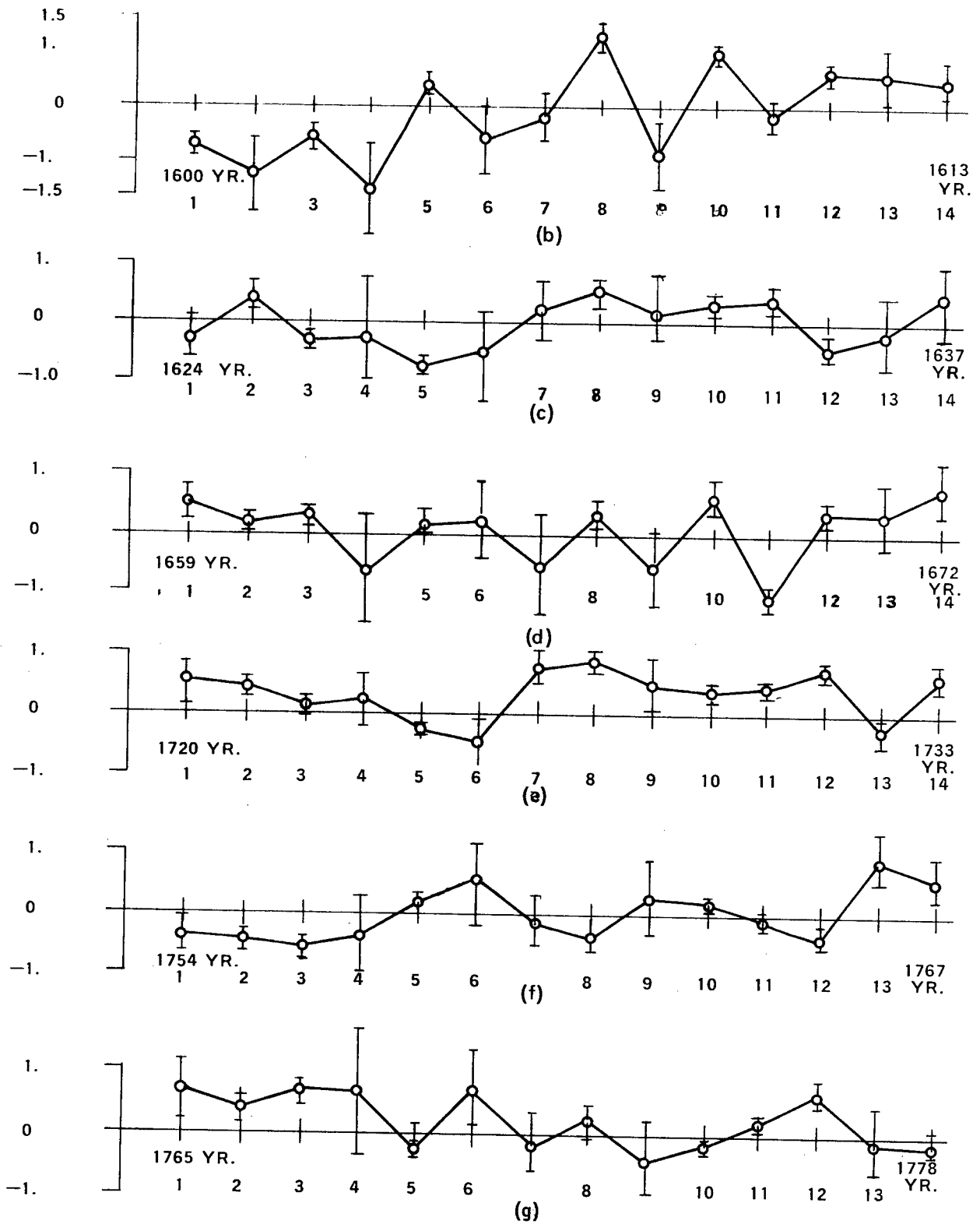


Figure 12 (Continued)



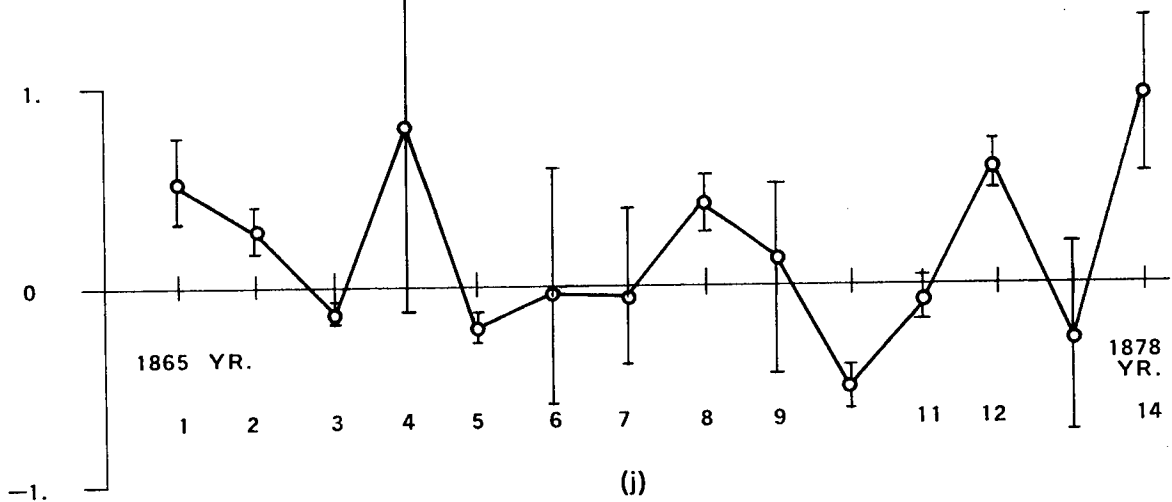
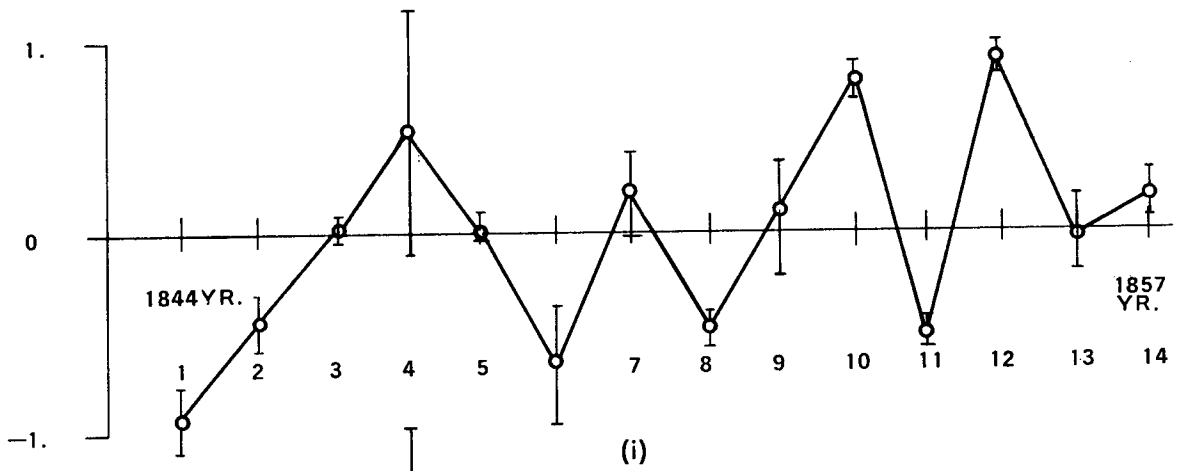
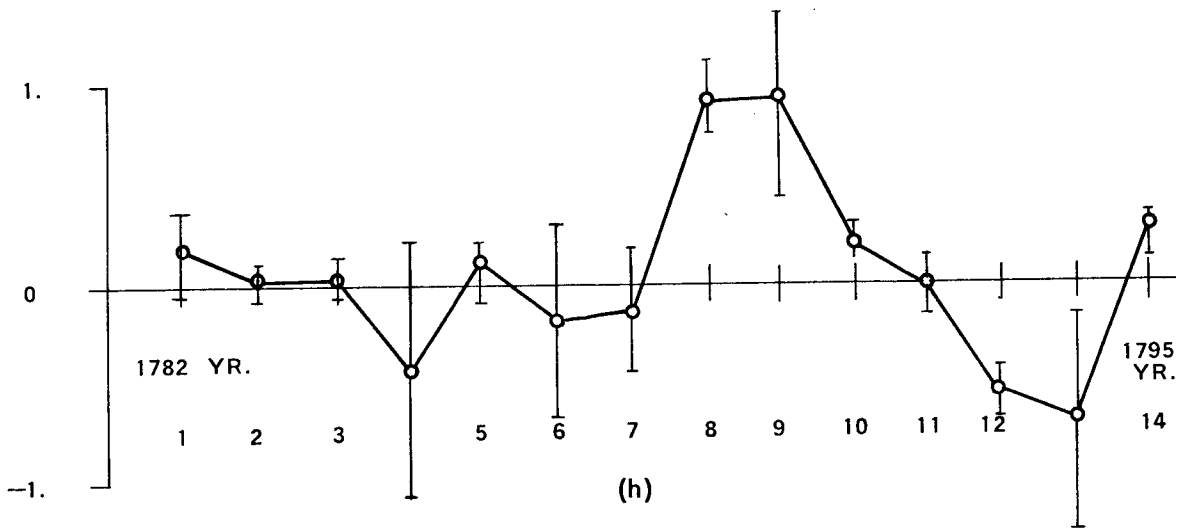


Figure 12 (Continued)

Regression based estimates of summer precipitation in Kamloops, Canada during: (a) 1553-1566, (b) 1600-1613, (c) 1624-1637, (d) 1659-1672, (e) 1720-1733, (f) 1754-1767, (g) 1765-1778, (h) 1782-1798, (i) 1844-1857, (j) 1865-1878.

Figure 13 is the plot of the average of the regression based estimates of the pre-summer precipitation. This average is averaged over the ten chronologies for each of the 14 years following the eruption. The error bases are the root-mean square of the errors of each of the ten values in the average.

Figure 14 compares the curve plotted in figure 13, re-normalized, to the normalized, average growth,  $\bar{d}^S_j$ , of the Fraser River Basin tree ring chronology. Note that since the precipitation estimates are of the preceding summer of the ring growth index, only 13 values are plotted. The striking feature of this plot is that the curves seem to have a high correlation. It is, in fact, 0.68 which seems to imply that the assumption that the tree growth in any one year is dependent on the precipitation in the summer preceding the growing season rather than on the summer of the current growing season is not strictly true. In fact, the dependence is on both and when one considers trees in the northern latitudes, the dependence on precipitation of the current growing season increases. This can be tested by repeating the experience using summer precipitation from the current growing season and then see which regression produces estimates with the highest precision. However, due to the sampling nature of the decomposition of the data systems into principal components, the components which heavily weight the first row of  $D^t_{NP}$  will not correlate highly with the similar component of  $Y_{NP}$ . For that reason, when one deals with a lagged array, a mistaken assumption on time coincidence does not cause a complete miss on the regression analysis.

The curves of figures 12 and 13 are interpretable as follows. The curve in figure 14 is a general estimate of the summer precipitations following an eruption of a large volcano, whereas the curves of figure 12 are specific estimates. The estimates are given by year with 90% confidence bounds. As one can see, some of the estimates have confidence bounds so large as to constitute essentially no estimate at all. Within the confidence bounds calculated for each point, the curve in figure 13 agrees with most of the curves in figure 12.

$$\bar{F} \pm \delta \bar{F}$$

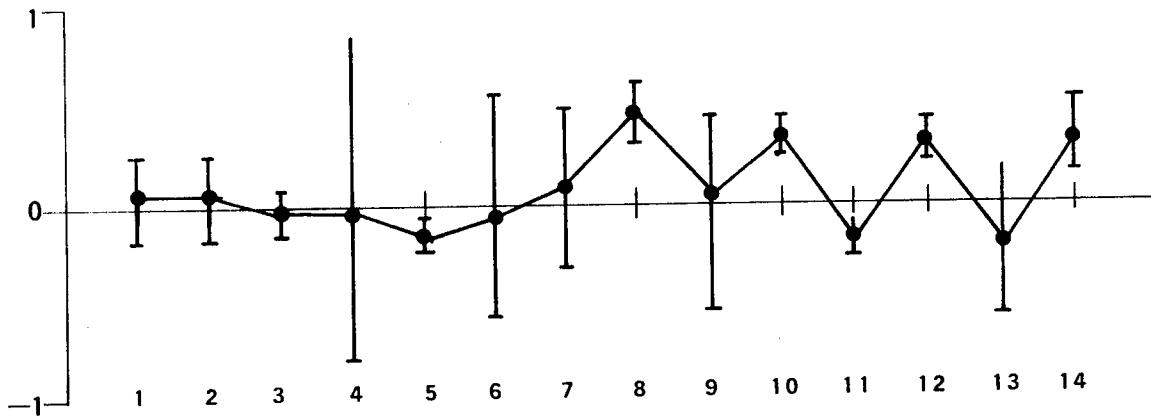


Figure 13

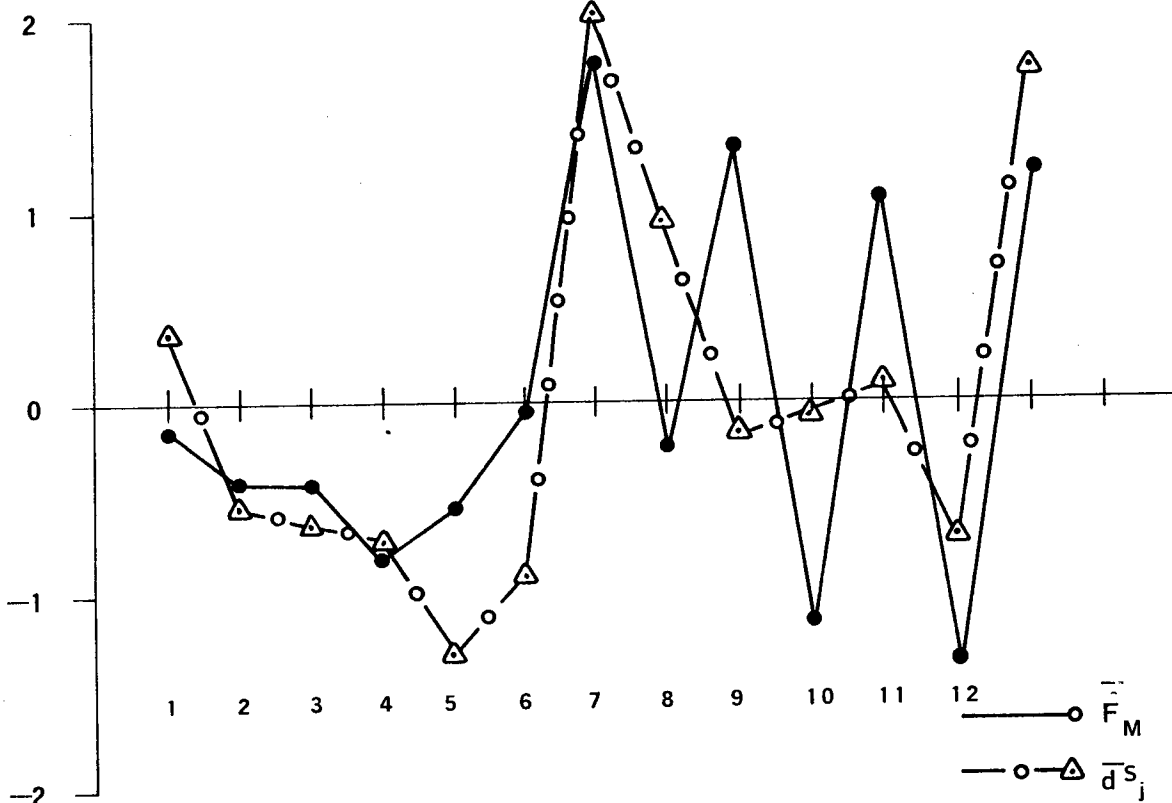


Figure 14

## REFERENCES

- (1) Lamb, H.H., Volcanic Dust in the Atmosphere, Roy. Soc. A., 266(1178), pp 425-533, 2 July 1970.
- (2) Schulman, E., Dendroclimatic changes in Semiarid America. University of Arizona Press, Tucson, Arizona, 1956.
- (3) Fritts, H.C., Computer Programs for Tree-Ring Research. Tree Ring Bulletin, 25 (3-4) 2-7.
- (4) Morrison, D. F., Multivariate Statistical Methods. McGraw-Hill Book Company, 1967.
- (5) Wilburn, J.B., Principal Component Regression Analysis. (In Preparation).
- (6) Fritts, H. C., Bristlecone Pine in the White Mountains of California - Growth and Ring Width Characteristics. Papers of the Laboratory of Tree-Ring Research, No. 4. University of Arizona Press, Tucson, Arizona, 1969.
- (7) Meteorological Data supplied by the Laboratory of Tree-Ring Research, University of Arizona, Tucson, Arizona.
- (8) Fritts, H. C., Dendroclimatology and Dendroecology. Quaternary Research, 1 (4), 1971.

APPENDIX A<sup>\*</sup>

---

\*The next article in these Proceedings is the appendix to the paper entitled "Progress to Date on Computing Regression Based Estimates of Climatic Changes Following Volcanic Eruptions".

# PRINCIPAL COMPONENT REGRESSION ANALYSIS

John Bart Wilburn

United States Army Electronic Proving Ground  
Fort Huachuca, Arizona 85613

**ABSTRACT:** Development of the mathematical rationale of multivariate regression between sets of principal components with a demonstration of a computer program implementing the rationale.

The intent of this paper is to propose a user-oriented method of multivariate linear regression which will reduce the uncertainty of the user by eliminating the unwanted effects of intercorrelation of variables and to enable the user to eliminate unnecessary variables with predictable results.

## Procedure:

The situation is that of two sets of data: Regressor data,  $D_{NM}$ ;  $N$  variables and  $M$  measurements and regressand data;  $F_{NM}$  also of  $N$  variables and  $M$  measurements. In general, the sets  $D$  and  $F$  will not be of the same number of variables, but for purposes of development, they will be considered the same without any loss of generality.

The user supposes that he has two systems,  $D$  and  $F$ , adequately described by the variables in each. The user further acknowledges that the systems are very likely noisy and that he has observed them long enough to have a representative sample of the variance in each and also that normality can be assumed. Having satisfied these assumptions, the user may proceed as follows:

First, compute the variance/co-variance matrices of the two normalized data sets

$$C^D_{NN} = \frac{1}{M-1} D_{NM} D'_{MN}$$

and

$$C^F_{NN} = \frac{1}{M-1} F_{NM} F'_{MN}$$

Next, perform the eigenvalue/eigenvector calculations

$$C^D_{NN} E_{NN} = E_{NN} \Lambda_{NN}$$

$$C_{NN}^F G_{NN} = G_{NN} \Omega_{NN}$$

where E and G are orthonormal sets, e.g.

$$\sum_i e_{ij}^2 = 1 \quad \text{and} \quad \sum_j e_{ij}^2 = 1.$$

The eigenvector sets are used to compute the principal components by the unitary transformation of:

$$X_{NM} = E'_{NN} D_{NM}$$

and

$$Y_{NM} = G'_{NN} F_{NM}.$$

Users from the physical sciences will recognize this as analogous to a principal axis transformation.

Each of these principal component sets consists of vectors which are independent and orthogonal. Furthermore, each of the vectors represents a specific "mode" of variance of the system which is independent and orthogonal to the other  $N - 1$  modes. The time-independent modes themselves are represented by the eigenvectors associated with the principal component in question indicating the relative contribution of each of the original  $N$  variables in  $D$  or  $F$  to that mode.

The following operation demonstrates the orthogonality properties of the principal components and also one other very useful property.

We will use the set  $X$  but the same applies to  $Y$ . Compute the variance/co-variance matrices of the principal components

$$\frac{1}{M-1} X_{NM} X'_{MN} = \frac{1}{M-1} E'_{NN} D_{NM} D'_{MN} E_{NN}.$$

The righthand side of the equation can be seen to be

$$E'_{NN} \left( \frac{1}{M-1} D_{NM} D'_{MN} \right) E_{NN} = E'_{NN} C^D_{NN} E_{NN}$$

which reduces to

$$E'_{NN} C^D_{NN} E_{NN} = \Lambda_{NN}.$$

Thus, the principal components are orthogonal and now we can see that the variance of each of the principal components is given by the eigenvalue associated with the eigenvector used to compute that particular component. Viewed in this way, the total variance of the original data,  $D_{NM}$ , is partitioned by the eigenvectors  $E_{NN}$  with the relative amount of the variance accounted for by the  $i^{\text{TH}}$  principal component given by

$$\text{Relative Var. } (X_{iM}) = \frac{\lambda_i}{\text{tr } \Lambda_{NN}}.$$

It should be noted here that if the variables in  $D$  and  $F$  are of the same units and variance, the correlation matrices  $C$  computed from the normalized data can be replaced by the co-variance matrix computed from unnormalized data. This may appeal to some users. However, under those conditions of equal variance and units, this writer's experience has been that the eigenvectors are very nearly the same as those from the correlation matrix. It is when the variances are not the same that the sampling properties of the eigenvectors differ depending on whether they are extracted from the correlation matrix or from the covariance matrix. It is my feeling that the correlation matrix is best for general use.

These properties, orthogonality, independence, and the partitioning of the variance will be seen to be very useful in the following development of the regression postulating the model of

$$Y_{NM} = \beta_{NN} X_{NM} + \epsilon_{NM}.$$

From the above comments, we now know that both the  $X_{NM}$  and  $Y_{NM}$  are distributed according to  $X_{NM} \sim N(0, \Lambda_{NN})$  and  $Y_{NM} \sim N(0, \Omega_{NN})$ .

Thus, the estimate of  $\beta_{NN}$ ,  $\hat{\beta}_{NN}$  is found by:

$$\hat{\beta}_{NN} = Y_{NM} X'_{MN} (X_{NM} X'_{MN})^{-1}$$

which reduces to

$$\hat{\beta}_{NN} = \frac{1}{M-1} Y_{NM} X_{MN} \Lambda^{-1}_{NN}$$



We can incorporate the factor  $\frac{1}{M-1}$  into the relationship by setting

$$\Lambda^*_{NN} = (M-1) \cdot \Lambda_{NN}$$

and similarly

$$\Omega^*_{NN} = (M-1) \cdot \Omega_{NN} \cdot$$

The matrix of the residual sum of squares  $\Sigma_{NN}$  of the regression estimated by the maximum likelihood method is estimated by  $\hat{\Sigma}_{NN}$  computed as follows:

$$\hat{\Sigma}_{NN} = \frac{1}{M} \{ (Y_{NM} - \hat{\beta}_{NN} X_{NM}) (Y_{NM} - \hat{\beta}_{NN} X_{NM})' \}$$

from which follows

$$\hat{\Sigma}_{NN} = \frac{1}{M} \{ Y_{NM} Y'_{MN} - \hat{\beta}_{NN} X_{NM} X'_{MN} \hat{\beta}'_{NN} \}$$

this reduces to

$$\hat{\Sigma}_{NN} = \frac{1}{M} \{ \Omega^*_{NN} - \hat{\beta}_{NN} \Lambda^*_{NN} \hat{\beta}'_{NN} \}$$

An unbiased estimate of  $\Sigma_{NN}$  is given by

$$\hat{\Sigma}^*_{NN} = \frac{M}{M-N} \hat{\Sigma}_{NN} \cdot$$

From the above formulation, we can identify the total sum of squares as the diagonal matrix  $\Omega^*_{NN}$  and the sum of squares due to regression as  $\hat{\beta}_{NN} \Lambda^*_{NN} \hat{\beta}'_{NN}$ .

#### GEOMETRIC INTERPRETATION:

The matrix  $\hat{\beta}_{NN} \Lambda^*_{NN} \hat{\beta}'_{NN}$  is the matrix of the vector products of the regression based estimates:  $\hat{Y}_{NM}$ .

This can be seen as

$$\hat{Y}_{NM} \hat{Y}'_{MN} = \hat{\beta}_{NN} X_{NM} X'_{MN} \hat{\beta}'_{NN}$$

where  $X_{NM} X'_{MN}$  is identified as  $\Lambda^*_{NN}$ . Viewed in the geometrical context, the diagonal terms of  $\hat{\beta}_{NN} \Lambda^*_{NN} \hat{\beta}'_{NN}$  are the lengths of the vectors  $\hat{Y}_{NM}$ . The off diagonal terms are the vector products  $\hat{Y}_{iM} \cdot \hat{Y}_{jM}$ ;  $i \neq j$ .

Thus

$$\hat{Y}_{iM} \cdot \hat{Y}_{jM} = |\hat{Y}_{iM}| \cdot |\hat{Y}_{jM}| \cos \phi .$$

Thus the off diagonal terms may be negative if  $\cos \phi < 0$ . However, since the vectors  $Y_{NM}$  are ideally orthogonal, the angle  $\phi$  is an error. By this argument, it is of no great consequence that the off-diagonal terms of  $\Sigma_{NN}$  may be negative in the computation.

While interpreting the regression geometrically, consider  $\hat{\beta}_{NN} X_{NM}$  as the projection into X space of  $Y_{NM}$  in Y space. Then  $|\hat{\beta} X|/|Y|$  is the cosine of the angle between  $Y_{NM}$ , and its projection  $\hat{\beta}_{NN} X_{NM}$ . Graphically, this would appear as follows considered in two dimensions.

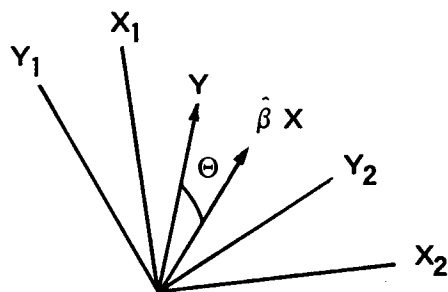


Figure 1

where

$$|Y| \cos \Theta = |\hat{\beta} X| .$$

Thus

$$\cos^2 \Theta = \frac{\hat{\beta}_{NN} X_{NM} X'_{MN} \hat{\beta}'_{NN}}{Y_{NM} Y'_{MN}}$$

or

$$\cos^2 \Theta = \frac{\hat{\beta}_{NN} \Lambda^*_{NN} \hat{\beta}'_{NN}}{\Omega^*_{NN}}$$

this can be identified

$$R^2_{NN} = \frac{\hat{\beta}_{NN} \Lambda^*_{NN} \hat{\beta}'_{NN}}{\Omega^*_{NN}}$$

Since the vectors  $\hat{Y}_{NM}$  are not, in general, completely orthogonal, and that the matrix  $\Omega_{NN}^*$  is a diagonal matrix, the off-diagonal elements of  $R_{NN}^2$  may be negative. However, we are actually only concerned with the diagonal elements; therefore, we can compute

$$R_{NN}^2 = \beta_{NN} \Lambda_{NN}^* \hat{\beta}'_{NN} \Omega_{NN}^{*-1} \delta_{NN}$$

The quantity  $R_{NN}^2$  is interpretable as the square of the multiple correlation coefficients of the regression equations  $\hat{\beta}_{NN}$ .

An F — test against the hypothesis  $C \hat{\beta} = 0$  can be provided from  $R^2$  by

$$\frac{R^2}{1 - R^2} \cdot \frac{M - N}{N - 1} \geq F_{N-1, M-N} (\gamma)$$

which is equivalent to

$$\frac{\hat{\beta}_{NN} \Lambda_{NN}^* \hat{\beta}'_{NN}}{M \hat{\Sigma}_{NN}} \cdot \frac{M - N}{N - 1} \geq F_{N-1, M - N} (\gamma).$$

Note that for the off-diagonal elements, the F — ratio is negative.

The multiple correlation coefficient squares, interpreted as the amount of variance of  $Y_{iM}$  explained by  $\hat{\beta}_{iN} X_{NM}$ , can be transformed into the coordinate system of  $F_{NM}$  so that the amount of variance of F variables explained by the D variables can be estimated. The transformation is simply the diagonal terms of

$$V(\hat{F}) = \frac{1}{t_r \Omega} \left\{ G_{NN} \Omega_{NN} (I_{NN} R_{NN}^2) G'_{NN} \right\}.$$

However, it is not clear just how useful this information is. What is useful to the user is a regression transformation from D to F and an expression for the confidence intervals on the estimates  $\hat{F}_{NM}$ .

The transfer function for computing  $\hat{F}$  is simply

$$\hat{F}_{NM} = (G_{NN} \hat{\beta}_{NN} E'_{NN}) D_{NM}$$

where the expression  $G_{NN} \hat{\beta}_{NN} E'_{NN}$  is identified as the transfer function

$$T_{NN} = G_{NN} \hat{\beta}_{NN} E'_{NN}$$

The calculation of the confidence intervals proceeds as follows and will illuminate some very useful consequences of the independence and orthogonality properties of the principal components.

The variance/co-variance of the regression equations can be computed by the following procedure:

$$V(\hat{\beta}_{ij}) = \xi (\beta_i - \hat{\beta}_i) (\beta_j - \hat{\beta}_j)'$$

$$V(\hat{\beta}_{ij}) = \xi \left\{ \sum_{\alpha} (Y_{i\alpha} - \hat{Y}_{i\alpha})(Y_{j\alpha} - \hat{Y}_{j\alpha})' X_{N\alpha} X'_{\alpha N} X \Lambda^*_{NN}^{-1} \Lambda^*_{NN}^{-1} \right\}$$

$$V(\hat{\beta}_{ij}) = \xi \left\{ \sum_{\alpha} (Y_{i\alpha} - \hat{Y}_{i\alpha})(Y_{j\alpha} - \hat{Y}_{j\alpha})' \Lambda^*_{NN}^{-1} \right\}$$

$$V(\hat{\beta}_{ij}) = \sigma_{ij} \cdot \Lambda^*_{NN}^{-1}$$

For  $i, j = 1, N$  this becomes

$$V(\hat{\beta}_{NN}) = \hat{\Sigma}^*_{NN} X \Lambda^*_{NN}^{-1}$$

Where  $\hat{\Sigma}^*_{NN}$  is the unbiased estimate of  $\Sigma_{NN}$ .

Recalling the previous argument regarding the off-diagonal elements of  $\hat{\beta}_{NN} \Lambda^*_{NN} \hat{\beta}'_{NN}$ , we may ignore them in which case  $V(\hat{\beta}_{NN})$  is a diagonal matrix of dimension  $N^2 \times N^2$ . It is worth noting that, in general, the off-diagonal elements are usually at least one or more orders of magnitude down from  $\hat{\beta}_{11} \Lambda^*_{11} \hat{\beta}'_{11}$ .

The matrix  $V(\hat{\beta})$  can be partitioned as:

$$V(\hat{\beta}) = \begin{bmatrix} v^1_{NN} & & & & \\ & v^2_{NN} & & & \\ & & \circ & & \\ & & & \ddots & \\ & & \circ & & v^N_{NN} \end{bmatrix}$$

Where the submatrix  $v_{NN}^k$  is a diagonal matrix for the  $k^{th}$  row of  $\hat{\beta}_{NN}, \hat{\beta}_{KN}$ . The submatrices are found by

$$v_{NN}^k = \sigma_{KK} \begin{bmatrix} \lambda_1^{*-1} & & & & & \\ & \lambda_2^{*-1} & & & & \\ & & \circ & & & \\ & & & \ddots & & \\ & & & & \lambda_N^{*-1} & \end{bmatrix}$$

where  $\sigma_{KK}$  is the  $k^{th}$  diagonal element of  $\hat{\Sigma}_{NN}^{*-1}$  and  $\lambda_j^{*-1}$  are the diagonal elements of  $\Lambda_{NN}^{*-1}$ . Thus, it is clear that

$$\text{COV}(\hat{\beta}_{k\ell}, \hat{\beta}_{kM}) = 0, \ell \neq M$$

as a consequence of the orthogonality of  $X_{NM}$ . This implies that the joint confidence regions of each of the regression equations are entirely unambiguous. This is vital to the interpretation of the confidence intervals of the estimates;  $\hat{F}_{NM}$ , as legitimate intervals. We can also see how the variance of the  $\hat{\beta}$  increases for the less important components of  $X$  for any given component in  $\hat{Y}$ .

The independence of the  $\hat{\beta}_{iN}$  for any given  $i$ , is of great help in the application of the regression analysis. This comes about when one recalls how the principal component transformation, in addition to its properties of independence and orthogonality, also possesses the property of having partitioned the variance of  $D$  and  $F$  into modes of variance which form a decreasing series of relative contribution to the total variance of the original data,  $D$  and  $F$ . Of concern here is the set  $D$  leading to  $X$ . If the set  $X_{NM}$  is too large in the dimension  $N$  as to be undesirable one can select those components which contain a prescribed amount of variance less than 100 percent. Thus,  $X_{NM}$  is replaced by  $X_{pM}; p < N$ . The assumption that the principal components have to be sorted has been made.

This selection of  $p$  components will cause the regression equation  $\hat{\beta}_{NN}$  to be  $\hat{\beta}_{pN}$ . What is important here is that the remaining  $p$  coefficients are unaffected by the rejection of the last  $N - p$  coefficients. Of course, the  $R^2_{NN}$  is lowered, but then the  $F$  - ratio may be increased because of the change in the degrees of freedom involved. The price paid for this reduction in the number of variables in  $X$  is that one may not know a priori which modes of variance in  $X$  will correlate with any one of the modes of variance in  $Y_{NM}$ . The decision must be made on the results of seeing all, or at least those allowed by computer limits tried first. For this reason, an interaction of the user is required in the use of this analysis. Also the  $F$  - test (as will be seen later) can be used in conjunction with the selection of  $p$  to improve the confidence interval calculation. The set  $Y_{NM}$  may also be reduced leading to  $\hat{\beta}_{qp}, q < N, q \leq p$ . However, this would preempt the  $F$  - test and therefore should be used only to satisfy the computer limits.

This confidence interval calculation proceeds as follows. We start with the confidence interval calculation of  $\hat{\beta}_{NN}$  :

$$\text{Conf } (1-\alpha, \hat{\beta}_{NN}) = t(M-N-1, 1-\alpha/2) \cdot \sqrt{V(\hat{\beta})}$$

For an individual row of the regression matrix this becomes

$$\text{Conf } (1-\alpha, \hat{\beta}_{KN}) = t(M-N-1, 1-\alpha/2) \sqrt{v^k_{NN}}$$

This can be expanded to compute the confidence interval of the results if an operation indicated by  $\xi_{1M}$  is performed to convert the  $M \times M$  matrix computed by

$$\text{Conf } (1-\alpha, \hat{Y}_{KM}) = t(M-N-1, 1-\alpha/2) \cdot \left[ X'_{NM} v^k_{NN} X_{NM} \right]^{1/2}$$

into a  $1 \times M$  matrix corresponding to the  $k^{\text{th}}$  row of  $Y_{NM}$ .

That is

$$\text{Conf } (1-\alpha, \hat{Y}^k_{1M}) = t(M-N-1, 1-\alpha/2) \cdot \left\{ \xi_{1M} \left[ X'_{MN} v^k_{NN} X_{NM} \right]^{1/2} \right\}$$

which can be re-written as

$$\delta Y^k_{1M} = t(M-N-1, 1-\alpha/2) \cdot \left\{ \xi_{1M} \left[ D'_{MN} E_{NN} v^k_{NN} E'_{NN} D_{NM} \right]^{1/2} \right\}$$

If this operation is done  $K = 1, N$  times,  $\delta Y^k_{1M}$  becomes a matrix  $\delta \hat{Y}_{NM}$  of confidence intervals of  $\hat{Y}_{NM}$ . Note that  $\delta Y$  decreases as the rank of  $v^k_{NN}$  decreases. This matrix of intervals can then be transformed back into  $F$ -space by  $G_{NN}$ . Thus we get the  $1-\alpha$  confidence intervals of  $F_{NM}$  by

$$\delta \hat{F}_{NM} = G_{NN} \delta \hat{Y}_{NM}$$

If the calculation of  $\delta \hat{Y}_{NM}$  is performed using independent data,  $D^*_{Nq}$  as would be applied to  $T_{NN}$ , the calculation would appear as

$$\hat{F}^*_{Nq} = T_{NN} D^*_{Nq}$$

and

$$\delta \hat{F}_{Nq}^* = G_{NN} \delta \hat{Y}_{Nq}^*$$

where

$$\delta \hat{Y}_{Nq}^* = \left[ t(M-N-1, 1-\alpha/2) \cdot \left\{ \xi_{1M} \left[ D_{qN}^* E'_{NN} v_{NN}^K E'_{NN} D_{Nq}^* \right]^{1/2} \right\} \right]_{K=1,N}$$

Note that E and G are from the calibration data, D and F, used to compute  $T_{NN}$  and  $v(\hat{\beta}_{NN})$ . The condition on  $D_{Nq}^*$  is that it comes from the same distribution as did  $D_{NM}$ . Note that if E and G come from the correlation matrix, then the estimates  $\hat{F} \pm \delta \hat{F}$  are in units of standard deviations.

A further refinement in the accuracy of the regression (over that of eliminating unnecessary components in  $X_{NM}$ ) can be introduced by using the F-test to reject (suppress to zero) entire regression equations. This has the effect of setting to zero components of  $\hat{Y}_{NM}$  which have insufficient probability of being more meaningful than zero. This amounts to a kind of stepwise regression except that the elimination of some of the components estimated in  $Y_{NM}$  leaves the remaining components unaffected since they are independent.

The application of the F-test rejection involves the calculation of  $R_{Np}^2$ ;  $p < n$  according to the amount of variance desired by the user based on experience. From the  $R_{Np}^2$ , the F-ratio is calculated. Those F-ratios failing the minimum value (95 % confidence level) cause the corresponding rows of  $\hat{\beta}_{NN}$  and submatrices  $v_{NN}^K$  to be set to zero and the calculation of  $T_{NN}$ ,  $\hat{F}_{NN}$ , and  $V(F_{NN})$  is repeated. The user can then manipulate  $p = p$  (% var. F) until the confidence intervals of  $\hat{F}_{NN}$  appear to be optimum. It should be noted that in most cases the values of  $t(M-N-1, 1-\alpha/2)$  do not change to much for changes in  $N$  to  $p$  amounting to a few integers, if  $M$  is several times as large as  $N$ . The value of the F-ratio,  $F_{M-p, p-1}(\gamma)$ , can be estimated from a simple polynomial in  $(M-p)$  with sufficient accuracy for use here.

The Var (F) can be estimated as mentioned earlier compounded by the amount of variance corresponding to the number of principal components  $\hat{Y}_{sq}^*$  passing the F-test rejection.

It is important to realize the physical implication of the means by which the accuracy of the regression is improved. By the initial assumptions about the data  $D_{NM}$  and  $F_{NM}$ , we claim normality and a representative sample of the behavior of the observed phenomena for all time. Further, we postulate a modal nature of the behavior or variance of the system as described by the  $N$ -variables. The modal nature of the variance is further postulated to be multimodal with modes numbering up to  $N$  and, in general, being of differing relative magnitude which linearly add up to comprise the total variance of the system.

With these observations in mind, we can now understand what is happening in the regression situation. When one or more of the least important principal components of  $X_{NM}$  are omitted, we are claiming that those modes of variance of  $D$  have an insignificant statistical relationship to any of the modes of variance of  $F$ . When we reject any of the regression equations by the  $F$ -test rejection, we are claiming that the mode of variance of  $F$  represented by that regression equation has an insignificant statistical relationship to all of the modes of variance of  $X$  used in the equation. It is important to reaffirm that one cannot say a priori which components of  $X$  will correlate highly with which components of  $Y$ . This will be clearer upon inspection of the demonstrated regression following. In any case, we can now understand that we are using as many as possible of the modes of variance of  $X$  that seem to have some significant statistical relationship to at least one of the modes of  $Y$  which passes the  $F$ -test. Further, we are allowing only those modes of variance of  $Y$  to be estimated which have a significant probability of not having been estimated by chance to be used to reconstruct the regressand  $F$ . In this way, we can see that it may well be possible that the modes of variance of  $X$  and  $Y$  that have a significant statistical relationship may or may not be the dominate modes in each and in any case the regression based estimate of  $F$  is a composite of significant modes estimated in  $Y$  without the interference of the insignificant ones. It may be possible to further improve the estimate by selectively eliminating the components of  $X$  for each regression equation in which the associated regression coefficient is insignificant. However, this would cause the degrees of freedom for each estimate  $\hat{Y}_{iM}$  to be, in general, different than for the other estimates. This would cause a rather cumbersome complication in the software and it is not clear just how beneficial it would be since the primary impact is on the confidence interval and not the estimate. Perhaps further work on the problem may answer these questions.

#### APPLICATION:

The regression analysis described in this paper has been implemented into two matching software packages: CORMAT and REGRESS. Attendant to these packages are two subroutines; CLEAR, which simply zero's out an array, and a CDC library subroutine MATRIX which performs matrix operations. The programs CORMAT and REGRESS are written so as to be used as subroutines themselves in a parent program which reads and formats the data  $D_{NM}$  and  $F_{NN} \cdot D_{Nq}^*$  is selected and formatted by another subroutine: SIGNAL.

The program CORMAT computes the correlation, or co-variance, matrix, depending on how it is called and also the eigenvalues/eigenvector and the principal components. The number of components computed is determined by the amount of variance requested to be accounted for. The maximum number of components is limited by the length of data and the size limitations of the machine. It is worth noting that the program CORMAT will compute the co-variance matrix about a mean value given to it which may be other than the mean value of the data supplied. In this way, one may investigate the modes of variance about a mean value from another distribution.



The output of CORMAT is the correlation, or co-variance, matrix, the list eigenvalues, the set of eigenvectors and the set of principal components computed accounting for the prescribed amount of variance of the input data. CORMAT writes the principal components, the reduced (if variance accounted for < 100%) set of eigenvectors and the list of eigenvalues used on a random access file and then returns. The number of eigenvectors used to compute the principal component are transferred between subroutines.

Subroutine REGRESS uses the principal component sets, the eigenvector sets and the independent regressor data (referred to as signal data) to compute the regression coefficients, the transfer function, the multiple correlation coefficients, the F-ratio and the regression based estimates of the regressand from the signal data. Subroutine REGRESS also performs the F-test rejection computation.

For an example application, the situation is the regression of tree ring data, the regressor, taken from the Fraser River Basin against matching precipitation data; the regressand, occurring during the summer months at Kamloops Meteorological Station, Kamloops, Alberta, Canada. The calibration data runs for 49 years from 1896 to 1944. The two data sets are lagged by 14 years. That is, the first column contains years 1 (referred to 1896) through 14, the second column years 2 through 15 and so on to column 36 containing years 36 to 49. The signal data,  $D_{NQ}^*$ , is composed of columns selected from  $D_{NM}$ , the tree ring data dating from 1500 to 1944, such that the tree ring indices in row 1 correspond to years in which a large volcano erupted in the region prescribed by the limits of long  $0^\circ$  to  $135^\circ$ W, latitude  $20^\circ$ N to  $90^\circ$ N. In appendix A are copies of the printout of the program with the conditions on percent of variance accounted for and F-test as described in the printout. Two other calculations were performed requesting 100% and 80% of the variance in  $D_{NS}$ . The effect can be seen in Figure 2 where the plots of  $F_{NS} + \delta \bar{F}_{NS}$  for the estimated precipitation in years 1783 - 1796 are shown as an example. The curves are: (a) 100% variance, with no F-test, (b) 100% variance with F-test, (c) 95% variance with F-test, (d) 90% variance with F-test and (e) 80% variance with F-test.

Upon inspection of Figure 2 we can see several effects at work, all of which involve the user as a student of the phenomena being analyzed rather than as a purely detached statistician.

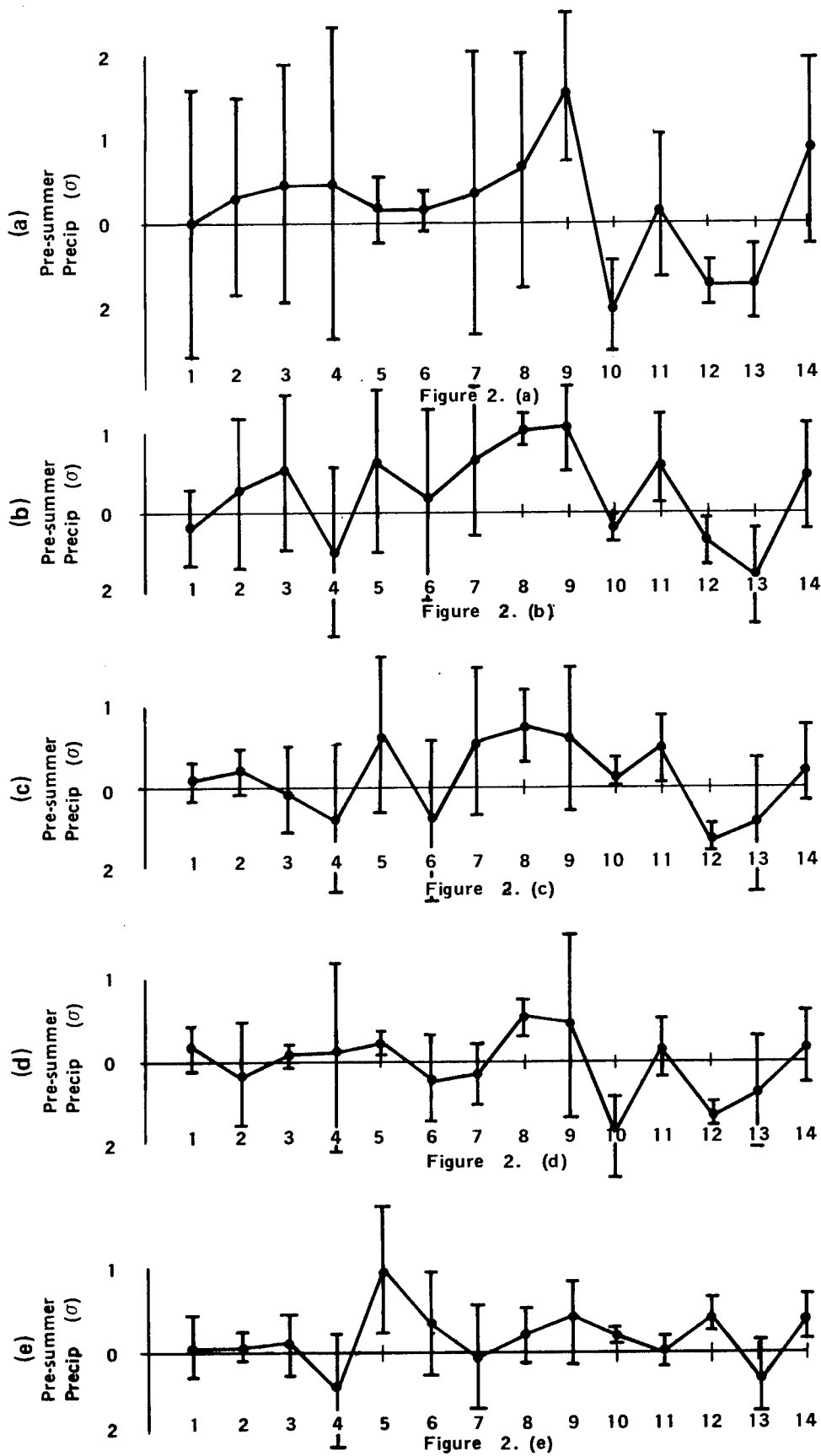


Figure 2

First, one sees the changing nature of the estimate  $\hat{F}_{iS}$  as fewer modes, or principal components, of  $X$  are allowed in the regression. Secondly, one notices that the 90% confidence bounds,  $\delta \hat{F}$ , of  $\hat{F}$  vary from one element to another within each of the rows of  $\hat{F}$  for each case (variance accounted for in  $X$ ). This is to be expected when one recalls the modal nature of the decomposition of the data into principal components. For any given mode of variance some of the variables may be emphasized and others may not. This is evident upon inspection of the associated eigenvectors. This is equivalent to identifying which variables are contributing significant amounts of variance to a particular mode and which are simply supplying noise.

On the other hand, if the noise is evenly distributed among the variables and if the entire mode is essentially a noise mode with none of the variables containing any significant amounts of signal, then none of the elements of the associated eigenvector will be prominent. If the noise is not evenly distributed, some of the elements may be prominent in a noise mode. However, remember that noise is random and unlikely to correlate with another set of data. Thus the coefficient  $\hat{\beta}$  will be small and the variance  $V_{NN}^K(B)$  will be large.

When one remembers that the modes are themselves partitioned with respect to the variance of the original data, it is easy to see how a variable contributing mostly noise in a dominate mode (dominated itself by signal) may still overpower the contribution of that same variable contributing mostly signal in a lesser mode.

Another fact which must be considered finally when inspecting the estimates  $\hat{F}$  is whether or not the noise evidenced by  $\delta \hat{F}$  is caused by uncertainty in  $\hat{\beta}$  or by the physical phenomena itself. This problem is largely self correcting to be one and the same when one assumes that the noise should be highly uncorrelated between the sets  $D$  and  $F$  and also recalls that the  $\hat{\beta}$  are independent within each regression equation. Thus, the regression coefficients should be essentially zero for noise and this in turn will cause  $V_{NN}^K$  to be large. Therefore, by disregarding an estimate in one case (variance accounted for) because of a large  $\delta \hat{F}$ , one is always sure of not overlooking a valid signal and by the same argument, keeping an estimate  $\hat{F}_{ij}$  from one case because of a small  $\delta \hat{F}$  and plotting it with another similarly good estimate  $\hat{F}_{iK}$  from a different case, each with their original  $\delta \hat{F}$ 's, one is simply combining good estimates of  $\hat{F}$  from  $D$  and disregarding noise. In a sense, one is simply keeping those components of  $X$  and  $\hat{Y}$  which contain mostly signal and discarding those which contain mostly noise.

Using these arguments, the final regression based estimate of pre-summer precipitation in Kamloops, Canada, for 14 years after the Icelandic volcano eruption in 1783 appears as shown in figure 3. The units are standard units of deviation about the mean and the error bars are 95% confidence bounds.

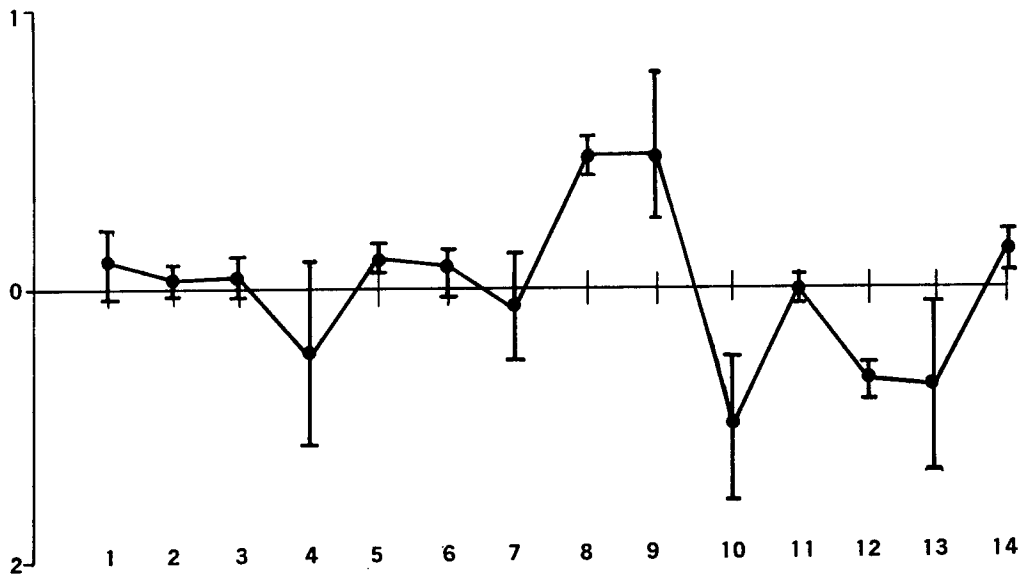


Figure 3

Before leaving the topic of inspection of results, note the transfer function itself (plates 6, 7 and 10). The reader will note the occurrence of "ridges" and "valleys" running diagonally from rows 1 and 6 and column 6.

Inspections such as this of the transfer function and also the eigenvectors, can reveal the likelihood of physical relationship between and within the sets F and D worthy of future causal investigations.

## ACKNOWLEDGEMENTS:

This work was funded by the US Army In-House Independent Research program at Fort Huachuca, AZ. The writer wishes to thank Dr. H.C. Fritts and T. J. Blazing of the University of Arizona for their many long and illuminating conversations on this subject.

## REFERENCES:

1. Hotelling, H. - Analysis of a Complex of Statistical Variables into Principal Components; J.E.P., 1933
2. Anderson, T.W. — An Introduction to Multivariate Statistical Analysis; John Wiley, 1958.
3. Hoel, P.G. — Introduction to Mathematical Statistics; Wiley, 1947.
4. Fritts, H.C. et al — Multivariate Techniques for Specifying Tree Growth and Climate Relationship and for Reconstructing Anomalies in Paleoclimate; Jnl. App. Met, Vol. 10, No. 5, Oct. 1971.
5. Sellers, W.D. — Climatology of Monthly Precipitation Patterns in Western United States, 1931—1966, Mon. Wea. Rev., Vol. 96, No. 9, Sep. 68.
6. Box, G.E.P., et al — Some Problems Associated with the Analysis of Multiresponse Data, Technometrics, Vol. 15, No. 1, Feb 73.
7. Draper, N.R, and Smith, H. — Applied Regression Analysis, Wiley, New York, 1966.
8. Schulman, E. — Dendroclimatic Changes in Semiarid America, Univ of Ariz. Press, Tucson, Az, 1956.
9. Meteorological Data Supplied by the Laboratory of Tree Ring Research, University of Arizona, Tucson AZ.
10. Lamb, H.H. — Volcanic Dust in the Atmosphere With a Chronology and Assessment of its Meteorological Significance, Royal Phil. Soc., Vol. 266, A, 1178, 2 Jul 1970.
11. Morrison, D.F., — Multivariate Statistical Methods, McGraw-Hill, New York, 1967.
12. Wilburn, J.B. — Multivariate Analysis Techniques Applied to Equipment Testing, Microelectronics and Reliability, Vol. 12, pp 535-538, Pergamon Press, 1973, Great Britain.

TREE RINGS MATCHING MET DATA

FRASER RIV 51LA12110

67.00	73.00	119.00	166.00	118.00	143.00	115.00	98.00	124.00	47.00	108.00	121.00	121.00	19.00
73.00	119.00	106.00	118.00	143.00	115.00	98.00	124.00	108.00	121.00	121.00	121.00	59.00	48.00
119.00	106.00	118.00	143.00	115.00	98.00	124.00	108.00	121.00	121.00	121.00	59.00	86.00	46.00
106.00	118.00	143.00	115.00	98.00	124.00	108.00	121.00	121.00	121.00	121.00	59.00	86.00	110.00
118.00	143.00	115.00	98.00	124.00	108.00	121.00	121.00	121.00	121.00	121.00	59.00	86.00	110.00
143.00	115.00	98.00	124.00	108.00	121.00	121.00	121.00	121.00	121.00	121.00	59.00	86.00	142.00
115.00	98.00	124.00	108.00	121.00	121.00	121.00	121.00	121.00	121.00	121.00	59.00	86.00	91.00
98.00	124.00	108.00	121.00	121.00	121.00	121.00	121.00	121.00	121.00	121.00	59.00	86.00	139.00
124.00	108.00	121.00	121.00	121.00	121.00	121.00	121.00	121.00	121.00	121.00	59.00	86.00	96.00
47.00	108.00	121.00	121.00	121.00	121.00	121.00	121.00	121.00	121.00	121.00	59.00	86.00	69.00
108.00	121.00	121.00	121.00	121.00	121.00	121.00	121.00	121.00	121.00	121.00	59.00	86.00	91.00
121.00	121.00	121.00	121.00	121.00	121.00	121.00	121.00	121.00	121.00	121.00	59.00	86.00	72.00
121.00	121.00	121.00	121.00	121.00	121.00	121.00	121.00	121.00	121.00	121.00	59.00	86.00	72.00
59.00	88.00	86.00	110.00	110.00	142.00	91.00	139.00	96.00	139.00	96.00	91.00	72.00	61.00
88.00	86.00	110.00	110.00	142.00	91.00	139.00	96.00	139.00	96.00	139.00	96.00	91.00	67.00
86.00	110.00	110.00	142.00	91.00	139.00	96.00	139.00	96.00	139.00	96.00	91.00	72.00	61.00
110.00	110.00	142.00	91.00	139.00	96.00	139.00	96.00	139.00	96.00	139.00	96.00	91.00	67.00
110.00	142.00	91.00	139.00	96.00	139.00	96.00	139.00	96.00	139.00	96.00	91.00	72.00	114.00
142.00	91.00	139.00	96.00	139.00	96.00	139.00	96.00	139.00	96.00	139.00	96.00	91.00	67.00
91.00	139.00	96.00	139.00	96.00	139.00	96.00	139.00	96.00	139.00	96.00	91.00	72.00	88.00
139.00	96.00	139.00	96.00	139.00	96.00	139.00	96.00	139.00	96.00	139.00	96.00	91.00	67.00
96.00	139.00	96.00	139.00	96.00	139.00	96.00	139.00	96.00	139.00	96.00	91.00	72.00	88.00
96.00	139.00	96.00	139.00	96.00	139.00	96.00	139.00	96.00	139.00	96.00	91.00	72.00	77.00
69.00	91.00	72.00	61.00	67.00	82.00	77.00	114.00	88.00	77.00	114.00	88.00	77.00	45.00
91.00	72.00	61.00	67.00	82.00	77.00	114.00	88.00	77.00	114.00	88.00	77.00	114.00	75.00
72.00	61.00	67.00	82.00	77.00	114.00	88.00	77.00	114.00	88.00	77.00	114.00	88.00	98.00
61.00	67.00	82.00	77.00	114.00	88.00	77.00	114.00	88.00	77.00	114.00	88.00	77.00	96.00
67.00	82.00	77.00	114.00	88.00	77.00	114.00	88.00	77.00	114.00	88.00	77.00	114.00	107.00
59.00	82.00	77.00	114.00	88.00	77.00	114.00	88.00	77.00	114.00	88.00	77.00	114.00	104.00
82.00	61.00	67.00	82.00	77.00	114.00	88.00	77.00	114.00	88.00	77.00	114.00	88.00	110.00
61.00	67.00	82.00	77.00	114.00	88.00	77.00	114.00	88.00	77.00	114.00	88.00	77.00	93.00
67.00	82.00	77.00	114.00	88.00	77.00	114.00	88.00	77.00	114.00	88.00	77.00	114.00	150.00
61.00	67.00	82.00	77.00	114.00	88.00	77.00	114.00	88.00	77.00	114.00	88.00	77.00	102.00
67.00	82.00	77.00	114.00	88.00	77.00	114.00	88.00	77.00	114.00	88.00	77.00	114.00	77.00
114.00	88.00	77.00	114.00	88.00	77.00	114.00	88.00	77.00	114.00	88.00	77.00	114.00	154.00
88.00	77.00	114.00	88.00	77.00	114.00	88.00	77.00	114.00	88.00	77.00	114.00	88.00	130.00
77.00	114.00	88.00	77.00	114.00	88.00	77.00	114.00	88.00	77.00	114.00	88.00	77.00	142.00
35.00	75.00	98.00	96.00	107.00	104.00	110.00	93.00	150.00	102.00	77.00	142.00	154.00	130.00

AVERAGE FOR EACH ROW OF DATA

92.083 92.306 93.000 92.361 92.389 92.000 91.083 90.472 91.917 91.306 92.139 93.083 94.000 94.250

STD. DEV FOR EACH ROW OF DATA

27.527 27.350 27.163 26.802 26.817 26.535 25.262 24.931 26.615 26.309 25.322 26.536 28.054 21.340

(PLATE 1)

Output from PRCOMP. Regressor (D<sub>NS</sub>) data of last 49 years of tree ring data coincident with precipitation data from 1896 to 1944.

CORRELATION MATRIX

1.00	.30	.11	.15	.09	-.03	.12	-.01	-.16	-.13	.03	-.11	-.28	-.15
.00	1.00	.24	.14	.15	.11	.01	.14	-.04	-.14	-.17	.01	-.12	-.26
.00	.00	1.00	.31	.15	.16	.16	.03	.15	-.01	-.19	-.14	.04	-.09
.00	.00	.00	1.00	.30	.13	.14	.14	.03	.12	.03	-.19	-.15	.02
.00	.00	.00	.00	1.00	.30	.12	.12	.16	.02	.15	.05	-.16	-.15
.00	.00	.00	.00	.00	1.00	.27	.10	.14	.14	.06	.15	-.05	-.17
.00	.00	.00	.00	.00	.00	1.00	.23	.12	.08	.24	.07	.14	.02
.00	.00	.00	.00	.00	.00	.00	1.00	.21	.09	.14	.22	.05	.11
.00	.00	.00	.00	.00	.00	.00	.00	1.00	.22	.07	.23	.32	.21
.00	.00	.00	.00	.00	.00	.00	.00	.00	1.00	.29	.07	.21	.31
.00	.00	.00	.00	.00	.00	.00	.00	.00	.00	1.00	.28	.08	.25
.00	.00	.00	.00	.00	.00	.00	.00	.00	.00	.00	1.00	.35	.13
.00	.00	.00	.00	.00	.00	.00	.00	.00	.00	.00	.00	1.00	.38
.00	.00	.00	.00	.00	.00	.00	.00	.00	.00	.00	.00	.00	1.00

EIGENVALUES

2.45	.37	2.20	.43	1.33	1.27	1.09	.96	.85	.76	.50	.70	.53	.56
ICOUNT= 1													

EIGENVECTORS

.26	-.18	.20	-.13	.29	.16	.43	-.18	.35	-.17	.12	-.32	-.12	.48
.24	.17	.31	.33	-.24	.17	.37	.14	.33	.32	-.27	.06	.34	-.24
.11	-.00	.36	-.17	-.31	-.40	.15	-.18	.10	-.15	.55	.11	-.15	-.37
.08	-.02	.38	.04	.26	-.42	.02	.21	-.05	-.04	-.47	.33	-.46	.10
.02	-.05	.42	-.30	.13	.10	-.38	.32	.12	-.38	.02	.14	.52	.06
-.09	-.05	.34	.34	-.14	.14	-.45	-.31	.05	.37	.24	.15	-.08	.40
-.16	.31	.33	-.13	-.12	.08	.14	-.62	-.42	-.12	-.28	-.09	.19	-.10
-.19	-.28	.27	-.10	.12	.18	.35	.40	-.57	.30	.24	-.03	.02	.07
-.32	.13	.20	.34	-.33	-.11	-.07	.24	-.01	-.35	-.08	-.62	-.13	.08
-.34	.08	.09	-.39	.23	-.31	-.12	.03	.32	.54	-.06	-.36	.06	-.10
-.32	-.24	.10	.39	.52	.25	-.01	-.07	.18	-.14	.14	.02	-.10	-.49
-.35	.37	.05	-.34	-.19	.51	.09	.12	.24	-.07	-.02	.26	-.42	-.00
-.43	-.61	-.06	-.09	-.37	-.11	.18	-.22	.18	-.09	-.30	.20	-.16	.10
-.38	.39	-.14	.25	.20	-.31	.31	.07	.08	-.09	.27	.31	.30	.33
ICOUNT= 2													

(PLATE 2)

Output from CORMAT processing regressor data D<sub>NN</sub> into C<sup>D</sup><sub>NN</sub>, E<sub>NN</sub>, Λ<sub>NN</sub> and X<sub>NN</sub>.

PRINCIPLE COMPONENTS

NUMBER OF ROWS= 14 NUMBER OF COLUMNS= 36  
 ICOUNT= 3

-0.94	1.98	-1.55	1.00	-1.53	-0.73	-0.95	-1.37	0.82	-0.15	-0.97	0.09	0.52	-0.73
0.04	2.26	1.34	1.04	-0.63	1.02	-0.09	1.13	1.77	-1.08	0.31	0.49	0.62	0.41
0.46	2.12	1.49	-1.63	-0.51	-1.20	1.25	-0.76	-0.70	-0.66	-0.02	-1.06	0.16	0.11
0.34	1.66	-1.31	-1.71	0.15	1.41	1.12	1.11	-0.33	0.91	-0.46	1.28	0.45	0.14
0.39	1.52	-0.68	0.04	2.39	1.09	-0.27	-1.60	-0.23	0.37	1.36	-0.37	0.15	-0.11
-0.32	0.88	0.70	-0.07	2.91	-1.19	-0.14	1.13	1.19	1.48	-0.71	-0.03	0.22	0.29
-0.79	0.68	-0.95	0.93	-0.08	-2.46	1.42	-0.86	0.15	-0.17	0.91	0.67	-0.31	-0.52
-0.60	0.62	0.55	1.77	-0.81	1.46	1.82	0.94	0.76	-0.25	-0.25	-0.85	0.20	0.20
-1.39	0.39	2.46	-1.21	0.38	0.59	0.74	-2.00	-0.28	0.06	-0.39	0.76	-0.26	-0.25
-1.78	0.40	-1.17	-1.97	0.49	0.37	0.25	1.61	0.37	-1.20	-0.58	-0.73	-0.06	-0.57
-0.71	1.24	-1.79	1.47	1.08	0.05	0.35	-0.43	-1.53	-0.71	-0.42	0.41	-0.40	0.63
-0.40	1.24	1.64	2.07	1.07	0.31	-0.70	1.06	-0.64	-0.01	0.09	0.16	1.14	-0.35
-0.43	1.12	1.40	-0.26	-0.85	-1.71	-0.49	0.36	-1.62	0.44	0.51	-0.17	-1.31	-0.31
0.00	1.35	-1.18	-0.10	-2.35	0.59	-0.75	0.42	-0.78	0.55	-0.56	-0.45	0.61	0.54
1.11	1.78	0.37	0.20	-0.53	1.52	-1.76	-0.56	-0.01	-0.26	0.33	0.70	-0.38	-0.65
1.81	1.66	0.50	0.99	0.05	-0.86	-1.53	-0.60	0.23	-0.62	-0.20	-1.29	-0.39	0.40
2.21	1.33	-1.02	-0.68	-0.61	-1.21	0.17	0.23	-0.10	0.52	-0.09	1.23	0.62	0.72
0.81	0.92	-0.53	0.55	-0.26	0.92	0.37	-0.02	0.31	0.27	1.55	-0.30	0.16	-0.76
2.95	0.25	0.93	-0.36	0.53	-0.03	0.02	-0.67	0.29	0.89	-0.97	-0.94	-0.89	0.19
1.93	-0.75	-0.17	-1.46	0.20	-0.67	0.16	-0.39	0.93	-0.34	-0.30	1.38	0.85	0.44
1.83	-1.19	-1.18	-0.34	0.59	0.11	1.15	0.58	0.54	-0.28	1.48	-0.37	-0.05	-0.48
1.75	-1.51	-0.21	0.89	0.91	0.09	1.09	-0.86	-0.20	0.95	-0.97	-0.77	-0.41	0.19
1.63	-1.83	0.35	1.06	-0.30	-0.13	-0.12	-0.08	-0.28	-1.30	-1.35	0.48	-0.21	-1.33
1.40	-2.16	0.88	0.09	-0.73	0.02	-0.01	0.98	-1.00	-1.35	0.17	-0.00	-0.32	1.29
0.97	-2.31	0.10	-0.97	-0.64	0.12	-0.27	0.10	-1.72	0.68	0.31	0.13	1.32	-0.19
0.51	-2.33	-1.11	-0.27	0.07	1.07	-1.63	0.15	-0.41	1.02	0.68	0.20	-0.95	-0.27
0.19	-2.11	-0.36	0.64	0.41	-0.60	-2.03	-0.88	0.97	0.22	-0.11	-0.75	0.37	0.62
-0.19	-1.96	0.16	0.64	-0.74	-1.49	-0.41	-0.68	1.59	0.07	0.04	0.82	-0.06	-0.39
-0.54	-1.83	0.12	0.32	-1.66	-0.20	1.32	-0.45	0.80	-0.19	1.00	-0.55	-0.16	0.69
-0.58	-1.54	0.43	-0.37	-0.84	1.42	0.96	-0.41	0.33	0.23	-1.21	-0.43	0.15	-0.96
-1.60	-1.59	0.39	-1.32	1.08	1.14	-0.12	-0.63	0.43	-1.08	-0.18	0.91	-0.52	0.85
-1.73	-1.13	-1.07	-0.29	1.42	-0.69	0.08	0.62	-0.33	-1.08	-0.05	-0.86	0.90	-0.72
-1.30	-0.51	-0.78	2.32	0.50	-0.36	0.50	0.61	-1.23	0.29	-0.43	0.60	-1.07	0.26
-2.16	-0.54	2.16	1.39	-0.10	-0.35	-0.44	-0.38	-0.37	0.27	0.63	0.14	1.46	0.59
-3.23	-0.44	1.25	-1.75	-0.43	-0.41	-0.46	-0.69	0.09	1.21	0.74	0.21	-0.61	-0.73
-3.53	0.39	-2.18	-0.57	-0.63	0.30	-0.28	-0.86	0.55	0.32	0.07	-0.72	-0.24	0.77

AMOUNT OF VARIANCE ACCOUNTED FOR 100 PERCENT NUMBER OF EIGENVALUES = 14

(PLATE 2 CONTINUED)



METEOROLOGICAL DATA  
PRE SUMMER PRECIP

1.01	.58	1.59	.61	1.70	1.01	1.76	.69	1.16	.60	1.59	1.27	.26
.58	1.59	.61	1.70	1.55	1.76	.69	1.16	.60	1.59	.26	1.27	1.27
1.59	.61	1.70	1.55	.91	1.76	.69	1.16	.60	1.59	.26	.89	.89
.61	1.70	1.55	.91	1.01	1.76	.69	1.16	.60	1.59	.26	.72	.72
1.70	1.55	.91	1.01	1.76	.69	1.16	.60	1.59	.26	.72	1.98	1.21
1.55	.91	1.01	1.76	.69	1.16	.60	1.59	.26	.72	1.98	1.21	.64
.91	1.01	1.76	.69	1.16	.60	1.59	.26	.72	1.98	1.21	.64	1.39
1.01	1.76	.69	1.16	.60	1.59	.26	.72	1.98	1.21	.64	1.39	1.09
1.76	.69	1.16	.60	1.59	.26	.72	1.98	1.21	.64	1.39	1.09	1.02
.69	1.16	.60	1.59	.26	.72	1.98	1.21	.64	1.39	1.09	1.02	1.28
1.16	.60	1.59	.26	1.27	.89	.72	1.98	1.21	.64	1.39	1.09	.69
.60	1.59	.26	1.27	.89	.72	1.98	1.21	.64	1.39	1.09	.69	.55
1.59	.26	1.27	.89	.72	1.98	1.21	.64	1.39	1.09	.69	.55	.68
.26	1.27	.89	.72	1.98	1.21	.64	1.39	1.09	.69	.55	.68	1.39
1.27	.89	.72	1.98	1.21	.64	1.39	1.09	.69	.55	.68	1.39	1.30
.89	.72	1.98	1.21	.64	1.39	1.09	.69	.55	.68	1.39	1.30	1.05
.72	1.98	1.21	.64	1.39	1.09	.69	.55	.68	1.39	1.30	1.05	.93
1.98	1.21	.64	1.39	1.09	.69	.55	.68	1.39	1.30	1.05	.93	1.80
1.21	.64	1.39	1.09	.69	.55	.68	1.39	1.30	1.05	.93	1.80	.89
.64	1.39	1.09	.69	.55	.68	1.39	1.30	1.05	.93	1.80	.89	.70
1.39	1.09	.69	.55	.68	1.39	1.30	1.05	.93	1.80	.89	.70	.57
1.09	.69	.55	.68	1.39	1.30	1.05	.93	1.80	.89	.70	.57	.80
1.02	1.28	.69	.55	.68	1.39	1.30	1.05	.93	1.80	.89	.70	.80
1.28	.69	.55	.68	1.39	1.30	1.05	.93	1.80	.89	.70	.80	.70
.69	.55	.68	1.39	1.30	1.05	.93	1.80	.89	.70	.80	.70	.57
.55	.68	1.39	1.30	1.05	.93	1.80	.89	.70	.80	.70	.57	.80
.68	1.39	1.30	1.05	.93	1.80	.89	.70	.80	.70	.57	.80	.54
.55	.68	1.39	1.30	1.05	.93	1.80	.89	.70	.80	.70	.57	.80
.68	1.39	1.30	1.05	.93	1.80	.89	.70	.80	.70	.57	.80	.66
1.39	1.30	1.05	.93	1.80	.89	.70	.80	.70	.57	.80	.66	.77
1.30	1.05	.93	1.80	.89	.70	.80	.70	.57	.80	.66	.77	1.10
1.05	.93	1.80	.89	.70	.80	.70	.57	.80	.66	.77	1.10	1.21
.93	1.80	.89	.70	.80	.70	.57	.80	.66	.77	1.10	1.21	.63
1.80	.89	.70	.80	.70	.57	.80	.66	.77	1.10	1.21	.63	1.10
.89	.70	.80	.70	.57	.80	.66	.77	1.10	1.21	.63	1.10	1.16
.70	.80	.66	.77	1.10	1.21	.63	1.10	1.16	.42	2.46	.42	.93
.70	.80	.66	.77	1.10	1.21	.63	1.10	1.16	.42	2.46	.42	.68

AVERAGE FOR EACH ROW OF DATA

1.049	1.043	1.042	1.016	1.020	1.004	.994	.986	.989	.972	.965	1.001	1.010	.955
-------	-------	-------	-------	-------	-------	------	------	------	------	------	-------	-------	------

STD. DEV FOR EACH ROW OF DATA

.426	.428	.429	.423	.420	.404	.394	.399	.399	.378	.387	.459	.454	.446
------	------	------	------	------	------	------	------	------	------	------	------	------	------

(PLATE 3)

Output from PRCOMP. Regressand data (F<sub>NS</sub>), the pre-summer precipitation.

CORRELATION MATRIX												
1.00	.24	.08	.10	-.03	-.21	-.00	-.27	-.05	.18	-.08	.24	.06
.00	1.00	-.22	.16	.11	-.03	-.22	-.27	.02	-.02	.10	-.08	.26
.00	.00	1.00	-.16	.09	.16	-.01	-.20	-.24	.04	-.12	.07	-.02
.00	.00	.00	1.00	-.11	.02	.09	.02	-.09	-.17	-.06	-.08	.04
.00	.00	.00	.00	1.00	-.07	.05	.10	-.17	-.08	-.19	-.08	-.03
.00	.00	.00	.00	.00	1.00	-.14	.11	-.08	-.15	-.07	-.16	-.16
.00	.00	.00	.00	.00	.00	1.00	.06	.04	-.07	-.09	-.04	-.23
.00	.00	.00	.00	.00	.00	.00	-.15	.07	.07	-.11	-.09	-.01
.00	.00	.00	.00	.00	.00	.00	1.00	-.16	.05	.09	-.14	-.10
.00	.00	.00	.00	.00	.00	.00	.00	1.00	-.14	.07	-.14	-.24
.00	.00	.00	.00	.00	.00	.00	.00	.00	1.00	-.24	.06	-.24
.00	.00	.00	.00	.00	.00	.00	.00	.00	.00	1.00	-.21	-.03
.00	.00	.00	.00	.00	.00	.00	.00	.00	.00	.00	1.00	-.18
.00	.00	.00	.00	.00	.00	.00	.00	.00	.00	.00	.00	1.00

EIGENVALUES													
1.85	.34	.39	1.64	.46	1.57	1.37	1.25	1.17	1.09	.84	.78	.66	.60
ICOUNT=	4												

EIGENVECTORS												
.41	.34	.22	-.23	.26	-.28	-.22	-.11	-.07	-.44	.10	-.37	-.25
-.49	.42	.30	-.23	-.10	-.07	-.07	-.03	.34	.10	-.47	.07	-.25
.36	.14	.28	-.09	-.42	.30	.08	-.05	.30	.33	.36	-.03	-.06
-.18	-.27	.11	-.01	-.44	-.19	-.08	-.23	-.37	-.18	-.02	.11	-.10
.00	-.39	.07	-.12	-.01	.23	.35	-.26	.51	-.36	.00	-.10	-.14
-.07	-.21	.24	.23	.40	.42	.17	.03	-.20	-.03	-.31	-.24	-.13
.23	.05	.38	.24	.29	-.10	.05	-.44	.41	.51	-.08	-.04	.00
-.30	.24	.40	-.04	.03	.04	.51	.16	-.33	-.19	.44	.16	.02
.26	.11	.30	.14	-.38	.38	-.23	.19	.31	-.31	-.36	.07	.23
-.12	-.17	.21	.34	-.33	-.45	.11	.30	.05	.11	-.07	-.60	.04
.19	-.33	.04	-.45	-.11	-.01	.07	.31	-.33	.26	-.15	-.04	-.54
-.20	-.30	.31	-.45	.13	.03	-.57	.18	.18	.18	-.37	.24	-.31
.22	-.25	.30	-.06	.10	-.44	.21	.17	.22	-.14	-.22	.49	.24
-.19	-.25	.29	-.55	.14	.08	-.27	-.02	-.05	.15	.08	-.24	.57
ICOUNT=	5											

(PLATE 4)

Output from CORMAT processing regressand data F<sub>NS</sub> into C<sup>F</sup><sub>NN</sub> · G<sub>NN</sub> · Ω<sub>NN</sub> and Y<sub>NS</sub>.

PRINCIPLE COMPONENTS

NUMBER OF ROWS = 14 NUMBER OF COLUMNS = 36

ICOUNT = 6

2.51	.66	1.99	1.80	.70	-1.19	.57	-1.13	-1.10	.62	-.32	-.33	.38	-.45
-3.57	.34	.14	.25	-1.30	1.04	-.04	-.56	1.10	-.22	-.33	-.40	.70	-.35
3.08	-.98	-.06	.45	-1.81	-.19	-1.26	1.05	-.47	.19	-.54	-.42	.56	-.02
-2.03	1.71	.45	.70	.45	-2.13	1.50	.42	.07	-.96	-.19	-.26	.78	-.47
.59	-2.83	1.28	-1.53	-1.26	1.80	.63	-.90	-1.10	-.39	.21	.35	.79	.13
-.39	-.90	-2.51	1.29	-.27	-2.26	-.98	-1.00	.65	.17	.42	.17	.80	-.40
1.55	1.49	.38	-1.74	-.28	.59	2.24	1.11	.45	.94	-.38	-.37	.62	-.23
-1.97	-2.21	.41	-1.50	1.50	-.91	-1.72	.02	-.93	.08	-1.74	.21	.22	-.28
1.72	-.48	-2.51	.94	.58	1.46	1.23	.06	.71	-2.07	.13	.21	.22	-.28
-.71	1.74	.13	-1.93	.35	-.43	-1.47	-.56	-1.61	-.38	1.09	-.38	.36	-.44
.79	-1.36	1.56	1.22	1.82	.72	-.26	-.41	2.04	.44	.12	-.25	.50	-.16
-1.37	1.07	-2.14	.79	-.76	1.63	-.38	1.46	-1.05	.77	-.42	.25	.91	.33
1.93	1.68	1.24	-.80	.28	-1.06	-1.28	1.16	-1.07	-1.36	-.66	.49	.67	-.09
-1.23	.02	1.63	2.24	.76	1.11	.71	-.47	-.57	-.06	-.86	.92	.40	-.42
-.29	.88	-1.10	.25	-2.25	.95	-1.01	-.62	-.18	-.06	-.14	-.63	-.64	-.71
-.84	-.08	1.68	-.07	-.61	-1.40	-.75	-.96	.54	-.32	1.27	-1.08	-.20	.16
-1.39	-.93	.41	1.24	-.26	-.32	1.89	.31	-.62	.66	.75	-.72	.42	-.62
.38	-.36	-1.16	-1.33	-1.71	-.30	.27	-1.16	-.12	.29	-.56	.68	.74	.97
.80	-.71	.36	-.36	.11	-1.28	-.05	.18	.76	.14	-.56	1.65	.44	.22
-1.13	-1.52	-.47	-.58	.46	.21	1.06	1.03	-.26	-.92	-1.16	.43	-.63	-1.09
.95	-.23	-1.59	-.70	.86	-.72	-.03	-1.01	-.89	.38	.39	-.85	-.27	-1.36
-.15	.61	.04	-.94	1.60	.44	.14	-.43	1.48	.77	.41	-1.24	.19	-.64
.04	-.36	-.46	.26	1.00	1.62	-1.42	1.23	-.41	.54	-.42	-.75	.42	.82
.19	1.59	-1.67	.51	.93	.30	-1.00	.59	-1.16	-.24	.12	.14	-.16	.95
.50	1.53	1.57	.75	.27	1.22	-.33	-1.04	-.34	-2.24	.77	.79	-.15	.42
-1.14	.88	.81	1.55	-.99	.57	-1.18	-1.10	1.34	-.11	.77	.07	-.78	.01
.64	.65	.71	.86	-2.16	.37	-.29	1.76	1.74	.46	.13	.10	-.77	.09
-1.02	.24	.16	.39	-.80	-1.97	.52	.82	.45	.56	.27	.06	-.72	.04
.17	-1.30	.40	-.06	-1.06	-.07	1.88	-.19	-.74	-.54	.29	.65	-.47	.22
-.30	-.33	-1.21	-.52	-1.26	-1.17	-.04	1.06	-.37	-.24	.17	.52	-.66	-.01
.64	-.81	.31	-1.21	.04	-.65	.69	1.31	1.27	-.97	-.62	-.47	-1.09	-.00
-.69	-1.30	-.83	-.30	1.19	-.55	.44	.76	-.129	-.00	-.34	-.72	-.94	.34
.98	.75	-1.45	-.61	1.02	.26	.55	-1.48	.18	-.11	-.81	-.32	-.81	.84
-.98	-1.88	.43	-1.91	.72	1.08	-1.52	.38	.86	-.26	-1.13	.23	-.92	1.20
1.14	-.20	-2.04	1.93	1.48	-.30	-.11	.69	-.27	1.54	2.07	.60	-.41	-.31
-.84	2.93	.04	-2.12	.84	.52	.73	.14	.47	1.54	1.47	.82	-.33	-.67
										.04	1.04	-.11	-.89

AMOUNT OF VARIANCE ACCOUNTED FOR 99 PERCENT NUMBER OF EIGENVALUES = 14

(PLATE 4 CONTINUED)

SIGNAL DATA

MAG.LIMITS	VOLCANIC CRITERIA	J#	LAT	LONG
500.0	5000.0	20.0	90.0	.0 135.0

VOLCANIC ERUPTIONS SELECTED

1554.0	1000.0	64.0	19.5
1601.0	1000.0	64.0	17.5
1625.0	800.0	63.5	19.0
1660.0	800.0	63.5	19.0
1721.0	750.0	63.5	19.0
1755.0	1200.0	63.5	19.0
1766.0	650.0	64.0	19.5
1783.0	2300.0	64.0	19.0
1845.0	800.0	64.0	19.5
1875.0	1000.0	65.0	17.0

(PLATE 5)

Output from SIGNAL: Extracting D\*<sub>NG</sub> from D<sub>NM</sub> (normalized) according to volcanic criteria listed.

AVERAGE FOR EACH ROW OF ORIGINAL DATA

98.704 98.539 98.650 98.669 98.685 98.609 98.569 98.609 98.729 98.785 98.752 98.640 98.928 98.900

STD. DEV FOR EACH ROW OF ORIGINAL DATA

32.024 31.963 31.877 31.873 31.876 31.823 31.798 31.781 31.877 31.862 31.877 31.944 32.043 32.011

SIGNAL DATA FROM NORMALIZED TOTAL

-.397	-1.425	-.397	-.617	-1.370	-.679	-.553	-.114	-.650	-.809	.478	-.558	1.095	-.528
1.165	.828	.576	.826	-.492	.012	.391	-.365	-.086	-.558	.165	1.351	1.687	1.315
-.990	-2.332	-.962	-.868	-1.025	-.522	2.152	1.806	1.295	-.746	.478	.287	.252	-.497
.353	-.299	1.109	-.366	-1.245	.012	2.278	1.680	.824	-.307	.855	-.120	2.624	.565
-.272	1.266	-1.275	-.052	.386	.232	1.523	.358	.354	-.746	-.369	.631	1.375	-.840
1.602	.104	.513	-.021	-.649	-.930	.768	2.183	.479	1.921	.729	2.040	2.187	-.372
2.039	2.204	-.365	.795	-.680	-1.873	-.678	-.995	.291	.195	.196	-2.249	.065	-.278
-.771	-.705	.293	.356	.794	.012	2.687	-.082	-.964	1.576	-.933	-.934	-.310	-.153
-.178	.077	-.773	-.680	-.429	.044	-.269	-.208	-.744	.509	-.180	-.120	.002	-1.434
.665	.014	.732	-.366	1.296	2.055	2.183	1.617	.448	.603	.980	-1.498	.189	.628

ICOUNT= 7

REGRESSION COEFFICIENTS

.01	.11	.06	.60	.52	.13	.12	.40	.41	.44
.10	.24	.32	.12	.28	.12	.12	.12	.51	.17
.08	.36	.30	.12	.14	.12	.05	.27	.09	.54
.04	.05	.41	.07	.11	.39	.40	.33	.15	.01
.20	.17	.38	.07	.42	.09	.47	.10	.05	.16
.04	.01	.23	.25	.44	.39	.26	.18	.30	.02
.02	.03	.34	.18	.24	.11	.18	.57	.08	.24
.03	.05	.22	.31	.09	.34	.18	.14	.25	.21
.01	.09	.17	.07	.05	.18	.20	.17	.64	.54
.09	.01	.00	.07	.19	.25	.07	.28	.13	.42
.12	.07	.27	.14	.01	.04	.35	.12	.28	.23
.04	.03	.04	.10	.11	.28	.27	.00	.04	.14
.06	.30	.14	.09	.01	.06	.08	.06	.00	.01
.07	.08	.04	.00	.21	.19	.06	.06	.08	.06

TRANSFER FUNCTION

.51	.07	.07	.49	.09	.16	.08	.01	.26	.17
.17	.58	.50	.38	.15	.14	.27	.02	.04	.17
.13	.20	.35	.13	.42	.08	.14	.24	.01	.01
.14	.19	.15	.04	.33	.07	.01	.18	.22	.03
.06	.12	.18	.47	.46	.27	.07	.05	.24	.19
.15	.03	.19	.14	.10	.43	.39	.03	.08	.17
.04	.12	.06	.18	.04	.27	.32	.42	.01	.14
.20	.08	.13	.15	.10	.16	.22	.29	.43	.06
.14	.15	.19	.20	.44	.06	.11	.27	.26	.27
.10	.14	.32	.07	.19	.04	.10	.03	.04	.10
.20	.07	.14	.20	.09	.41	.48	.04	.04	.27
.08	.11	.03	.08	.17	.08	.21	.51	.13	.02
.42	.05	.25	.08	.08	.12	.21	.22	.63	.14
.05	.09	.08	.30	.04	.02	.00	.22	.06	.64
.14	.52	.06	.11	.10	.16	.22	.06	.31	.06

REGRESSION BASED ESTIMATE OF REGRESSAND

.13	.59	.85	1.76	.22	.13	.40	.55	-2.40	.74
.37	.89	.44	.20	1.02	.53	.35	.13	.38	1.02
.53	.41	.15	.20	.04	.21	.12	.02	.70	.42
.01	.74	.27	.31	.81	.59	.11	.65	.38	.62
.92	1.40	.59	.85	1.34	.35	.29	1.18	.05	1.83
.59	.56	.74	.56	.37	.11	.33	.67	1.06	1.03
1.20	.42	1.16	.34	.41	.21	.75	.90	.37	.03
.02	.27	.38	.07	.62	1.05	.12	.70	.72	.68
-1.01	.50	.36	.28	.90	1.51	.88	.70	.19	1.17
.87	.43	.18	.72	.28	1.38	.93	.04	.99	.53

(PLATE 6)

Output from Regress using 100% variance of regressor data and before the F-test rejection has been employed.

VARIANCE OF REGRESSION COEFFICIENTS-DIAGONAL

MATRIX NUMBER	1	.01	.02	.02	.02	.03	.03	.03	.04	.04	.05	.05	.06
MATRIX NUMBER	2	.02	.04	.04	.05	.06	.06	.07	.08	.08	.09	.11	.13
MATRIX NUMBER	3	.03	.03	.04	.04	.05	.05	.06	.07	.08	.09	.11	.11
MATRIX NUMBER	4	.03	.03	.04	.04	.05	.05	.06	.07	.07	.08	.09	.11
MATRIX NUMBER	5	.02	.02	.03	.03	.03	.04	.04	.05	.06	.06	.07	.08
MATRIX NUMBER	6	.02	.02	.02	.02	.02	.03	.03	.04	.04	.05	.05	.05
MATRIX NUMBER	7	.01	.02	.02	.02	.02	.03	.03	.04	.04	.04	.05	.05
MATRIX NUMBER	8	.02	.02	.02	.02	.03	.03	.03	.04	.04	.05	.06	.06
MATRIX NUMBER	9	.01	.01	.01	.01	.02	.02	.02	.03	.03	.03	.04	.04
MATRIX NUMBER	10	.01	.01	.02	.02	.02	.02	.02	.03	.03	.04	.05	.05
MATRIX NUMBER	11	.01	.01	.01	.01	.01	.02	.02	.02	.02	.03	.03	.03
MATRIX NUMBER	12	.01	.01	.01	.01	.02	.02	.02	.03	.03	.03	.04	.04
MATRIX NUMBER	13	.00	.00	.01	.01	.01	.01	.01	.01	.01	.01	.02	.02
MATRIX NUMBER	14	.00	.01	.01	.01	.01	.01	.01	.02	.02	.02	.02	.02

CONFIDENCE INTERVAL OF ESTIMATE

1.17	.80	1.00	2.43	.27	.09	1.29	1.05	.59	.33	.62	.14	.41	.77
1.20	.82	1.03	2.50	.27	.09	1.32	1.07	.61	.34	.64	.14	.42	.79
1.63	1.11	1.40	3.39	.37	.12	1.79	1.45	.82	.45	.86	.19	.57	1.07
1.58	1.08	1.36	3.28	.36	.12	1.74	1.41	.80	.44	.84	.19	.55	1.03
1.31	.89	1.12	2.72	.30	.10	1.44	1.17	.66	.37	.69	.15	.46	.86
1.87	1.28	1.60	3.89	.43	.14	2.06	1.67	.94	.52	.99	.22	.65	1.22
1.74	1.19	1.49	3.62	.40	.13	1.92	1.55	.88	.49	.92	.20	.61	1.14
1.65	1.12	1.41	3.42	.38	.12	1.81	1.47	.83	.46	.87	.19	.57	1.08
.82	.56	.70	1.71	.19	.06	.90	.73	.41	.23	.43	.10	.29	.54
1.56	1.06	1.34	3.24	.36	.12	1.71	1.39	.79	.43	.83	.18	.54	1.02

CORRECTED BY F-TEST REJECTION

REGRESSION COEFFICIENTS

-.01	.01	.11	-.11	.03	-.60	.06	-.82	-.52	-.13	.12	-.40	-.43	-.44
.00	.00	.00	.00	.00	.00	.00	.00	.00	.00	.00	.00	.00	.00
.00	.00	.00	.00	.00	.00	.00	.00	.00	.00	.00	.00	.00	.00
.00	.00	.00	.00	.00	.00	.00	.00	.00	.00	.00	.00	.00	.00
.00	.00	.00	.00	.00	.00	.00	.00	.00	.00	.00	.00	.00	.00
.04	-.01	.07	-.30	-.06	.00	-.23	-.49	-.44	-.39	.26	.18	.30	-.02
-.02	.03	-.33	-.10	-.07	-.18	.34	-.39	.24	.11	.18	.57	.08	.24
.00	.00	.00	.00	.00	.00	.00	.00	.00	.00	.00	.00	.00	.00
.01	-.01	.09	.11	.17	.10	-.07	-.29	.05	.18	-.20	.17	-.64	.54
.00	.00	.00	.00	.00	.00	.00	.00	.00	.00	.00	.00	.00	.00
-.12	-.07	.02	-.22	.12	-.14	-.27	.10	-.01	.04	.35	.12	.24	.23
.00	.00	.00	.00	.00	.00	.00	.00	.00	.00	.00	.00	.00	.00
.06	.30	-.01	.02	.16	-.09	.14	.06	.01	-.06	.08	.06	-.00	-.01
.00	.00	.00	.00	.00	.00	.00	.00	.00	.00	.00	.00	.00	.00

TRANSFER FUNCTION

.30	.17	.07	.07	.13	-.24	.22	-.18	.03	.06	.02	.02	.22	-.28
-.21	.41	-.02	-.02	-.08	.01	-.44	.07	-.10	-.07	.09	.01	-.06	.17
.36	-.22	.32	.05	.14	-.09	.22	-.30	-.12	.06	-.26	.24	-.19	.05
-.04	.11	-.18	.24	-.17	.09	-.08	.18	-.19	.17	-.07	.06	-.03	-.10
.03	-.01	.27	-.29	.23	.00	-.07	-.15	.21	-.24	.13	.05	-.06	.12
.01	.18	-.08	.31	-.22	.27	-.11	.03	-.28	.22	-.09	-.05	.21	-.11
.10	.03	.10	-.15	.16	-.21	-.18	-.01	.24	-.08	.27	-.20	.06	-.19
-.01	.10	-.07	.07	-.01	-.07	.01	.31	-.08	.08	-.07	.27	-.35	.06
.01	.11	-.04	-.10	.03	-.12	.21	.01	.23	-.04	.31	-.44	.17	-.19
-.03	.11	-.05	-.02	-.00	.09	-.04	.05	-.02	-.01	.02	.01	-.06	.08
.12	-.06	-.17	.10	.07	-.21	.00	.01	.10	.04	.22	-.05	.13	-.50
.10	.02	.18	-.02	.13	.02	-.11	.04	-.07	-.03	-.11	.39	-.21	.09
.13	.03	.19	-.02	.01	.09	.17	-.22	-.02	.03	-.02	-.21	.29	.06
-.13	.18	.02	-.06	-.09	.11	.09	.17	-.03	.01	-.05	-.08	-.18	.32

REGRESSION BASED ESTIMATE OF REGRESSAND

.27	.38	.33	.69	.38	1.19	.70	.63	.15	-.01	-.54	.18	-1.99	-.69
-.39	-1.12	-.36	-1.46	-.07	.15	-.25	1.23	-.58	.52	-.16	.97	-.23	.89
-.36	-.11	-.09	-.07	-.34	-.43	.18	.48	.10	.11	.44	-.34	-.22	.10
-.22	-.04	-.38	-.69	-.38	-.77	-.54	.28	.03	.46	-1.20	-.07	.26	.49
.49	.18	.50	-.14	.13	-.32	.81	.83	.42	.32	.91	.07	-.04	.82
-.76	-.22	.15	-.66	-.10	.52	-.55	.04	-.05	-.22	.43	-.48	.89	1.23
.66	.07	1.42	.27	.15	1.21	-.28	.06	-.36	-.10	-.08	-.18	-.09	-.19
-.11	.22	.54	-.45	.62	.10	.59	.94	.07	-.16	.63	-.34	-.73	.39
-.72	-.81	-.43	.27	-.88	-.43	-.29	.90	.09	-.69	-.50	1.06	.17	.09
.64	.59	-.19	.84	-.52	-.03	-.02	.19	-.14	-.50	-.25	.24	-.36	.76

(PLATE 7)

Output from REGRESS, using 100% variance of regressor data after the F-test rejection has been employed.



SUM OF SQUARES DUE TO REGRESSION

47.04	.00	.00	.00	.00	.00	7.10	2.79	.00	2.17	.00	.90	.00	.83
.00	.00	.00	.00	.00	.00	.00	.00	.00	.00	.00	.00	.00	.00
.00	.00	.00	.00	.00	.00	.00	.00	.00	.00	.00	.00	.00	.00
7.10	.00	.00	.00	.00	.00	.00	.00	.00	.00	.00	.00	.00	.00
2.79	.00	.00	.00	.00	.00	25.41	-1.40	.00	1.14	.00	-.23	.00	-2.19
.00	.00	.00	.00	.00	.00	-1.40	23.39	.00	1.95	.00	.89	.00	2.52
2.17	.00	.00	.00	.00	.00	.00	.00	.00	16.46	.00	-2.62	.00	.66
.00	.00	.00	.00	.00	.00	1.14	1.95	.00	.00	.00	.00	.00	.00
.00	.00	.00	.00	.00	.00	.00	.00	.00	.00	.00	11.72	.00	1.54
.00	.00	.00	.00	.00	.00	-.23	.89	.00	-2.62	.00	.00	.00	.00
.83	.00	.00	.00	.00	.00	.00	.00	.00	.00	.00	.00	.00	.00
.00	.00	.00	.00	.00	.00	-2.19	2.52	.00	-.66	.00	-1.54	.00	9.38
.00	.00	.00	.00	.00	.00	.00	.00	.00	.00	.00	.00	.00	.00

MEAN SQUARE RESIDUAL

.49	.00	.00	.00	.00	.00	-.20	-.08	.00	-.06	.00	.03	.00	-.02
.00	1.60	.00	.00	.00	.00	.00	.00	.00	.00	.00	.00	.00	.00
.00	.00	1.52	.00	.00	.00	.00	.00	.00	.00	.00	.00	.00	.00
.00	.00	.00	1.33	.00	.00	.00	.00	.00	.00	.00	.00	.00	.00
.00	.00	.00	.00	1.21	.00	.00	.00	.00	.00	.00	.00	.00	.00
.20	.00	.00	.00	.00	.00	.43	.04	.00	-.03	.00	.01	.00	.06
.08	.00	.00	.00	.00	.00	.04	.41	.00	-.05	.00	-.02	.00	.07
.00	.00	.00	.00	.00	.00	.00	.00	.82	.00	.00	.00	.00	.00
.06	.00	.00	.00	.00	.00	-.01	-.05	.00	.30	.00	.07	.00	.00
.00	.00	.00	.00	.00	.00	.00	.00	.00	.00	.64	.00	.00	.00
.03	.00	.00	.00	.00	.00	.00	.00	.00	.07	.00	.25	.00	.04
.00	.00	.00	.00	.00	.00	.00	.00	.00	.00	.00	.00	.45	.00
.02	.00	.00	.00	.00	.00	.00	.00	.00	.02	.00	.04	.00	.12
.00	.00	.00	.00	.00	.00	.06	-.07	.00	.00	.00	.00	.00	.00
.00	.00	.00	.00	.00	.00	.00	.00	.00	.00	.00	.00	.00	.33

MULTIPLE CORRELATIONS COEFFICIENTS SQUARED

.73	.00	.00	.00	.00	.00	.62	.61	.00	.60	.00	.56	.00	.69	.00
-----	-----	-----	-----	-----	-----	-----	-----	-----	-----	-----	-----	-----	-----	-----

F RATIO ( 13, 22) DEG

4.50	.00	.00	.00	.00	.00	2.79	2.68	.00	2.56	.00	2.17	.00	3.72	.00
------	-----	-----	-----	-----	-----	------	------	-----	------	-----	------	-----	------	-----

UNBIASED RESIDUALS

.80	.00	.00	.00	.00	.00	-.32	-.13	.00	-.10	.00	.04	.00	-.04	.00
.00	2.62	.00	.00	.00	.00	.00	.00	.00	.00	.00	.00	.00	.00	.00
.00	.00	2.49	.00	.00	.00	.00	.00	.00	.00	.00	.00	.00	.00	.00
.00	.00	.00	2.14	.00	.00	.00	.00	.00	.00	.00	.00	.00	.00	.00
.32	.00	.00	.00	1.94	.00	.00	.00	.00	.00	.00	.00	.00	.00	.00
.13	.00	.00	.00	.00	.00	.70	.06	.00	-.05	.00	.00	.00	.00	.00
.00	.00	.00	.00	.00	.00	.06	.67	.00	-.09	.00	.04	.00	.11	.00
.10	.00	.00	.00	.00	.00	.00	.00	1.34	.00	.00	.00	.00	.00	.00
.00	.00	.00	.00	.00	.00	-.05	-.09	.00	.49	.00	.12	.00	.03	.00
.04	.00	.00	.00	.00	.00	.00	.00	.00	.00	1.05	.00	.00	.00	.00
.00	.00	.00	.00	.00	.00	.01	-.04	.00	.12	.00	.42	.00	.07	.00
.04	.00	.00	.00	.00	.00	.00	.00	.00	.00	.00	.00	.74	.00	.00
.00	.00	.00	.00	.00	.00	.10	-.11	.00	.03	.00	.07	.00	.19	.00
.00	.00	.00	.00	.00	.00	.00	.00	.00	.00	.00	.00	.00	.00	.54

(PLATE 7 CONTINUED)

VARIANCE OF REGRESSION COEFFICIENTS-DIAGONAL

MATRIX NUMBER	1	2	3	4	5	6	7	8	9	10	11	12	13	14
MATRIX NUMBER	.01	.00	.00	.00	.00	.00	.01	.01	.01	.00	.00	.00	.00	.00
MATRIX NUMBER	.02	.00	.00	.00	.00	.02	.02	.02	.00	.00	.01	.00	.00	.00
MATRIX NUMBER	.03	.00	.00	.00	.00	.03	.03	.03	.00	.00	.01	.00	.00	.00
MATRIX NUMBER	.04	.00	.00	.00	.00	.04	.04	.04	.00	.00	.02	.00	.00	.00
MATRIX NUMBER	.05	.00	.00	.00	.00	.05	.05	.05	.00	.00	.03	.00	.00	.00
MATRIX NUMBER	.06	.00	.00	.00	.00	.06	.06	.06	.00	.00	.04	.00	.00	.00
MATRIX NUMBER	.07	.00	.00	.00	.00	.07	.07	.07	.00	.00	.04	.00	.00	.00
MATRIX NUMBER	.08	.00	.00	.00	.00	.08	.08	.08	.00	.00	.04	.00	.00	.00
MATRIX NUMBER	.09	.00	.00	.00	.00	.09	.09	.09	.00	.00	.04	.00	.00	.00
MATRIX NUMBER	.10	.00	.00	.00	.00	.10	.10	.10	.00	.00	.04	.00	.00	.00
MATRIX NUMBER	.11	.00	.00	.00	.00	.11	.11	.11	.00	.00	.04	.00	.00	.00
MATRIX NUMBER	.12	.00	.00	.00	.00	.12	.12	.12	.00	.00	.04	.00	.00	.00
MATRIX NUMBER	.13	.00	.00	.00	.00	.13	.13	.13	.00	.00	.04	.00	.00	.00
MATRIX NUMBER	.14	.00	.00	.00	.00	.14	.14	.14	.00	.00	.04	.00	.00	.00

CONFIDENCE INTERVAL OF ESTIMATE

.29	.61	.64	.73	.96	.66	.08	.40	.06	.41	.22	.39	.40
.30	.63	.65	.75	.99	.68	.08	.41	.06	.42	.22	.40	.41
.39	.85	.88	1.02	1.34	.92	.11	.56	.09	.58	.30	.54	.55
.32	.68	.71	.82	1.30	.89	.11	.54	.08	.56	.29	.53	.53
.46	.97	1.01	1.17	1.08	.74	.09	.45	.07	.46	.24	.44	.44
.43	.91	.94	1.20	1.54	1.06	.13	.64	.10	.66	.34	.62	.63
.41	.86	.89	1.09	1.43	.94	.12	.59	.09	.61	.32	.58	.59
.27	.43	.45	1.03	1.35	.93	.12	.56	.09	.58	.30	.55	.56
.39	.81	.85	.98	1.28	.88	.11	.28	.04	.29	.15	.27	.28
					.88	.11	.53	.08	.55	.29	.52	.53

(PLATE 7 CONTINUED)

CORRELATION MATRIX													
1.00	.30	.11	.15	.09	-.03	.12	-.01	-.16	-.13	.03	-.11	-.28	-.15
.00	1.00	.29	.14	.15	.11	.01	.14	-.04	-.14	-.19	.01	-.12	-.28
.00	.00	1.00	.31	.15	.18	.16	.03	-.04	-.01	-.19	-.14	-.04	-.09
.00	.00	.00	1.00	.30	.13	.14	.14	.03	.12	.03	-.19	-.15	-.02
.00	.00	.00	.00	1.00	.30	.12	.10	.16	.02	.15	.05	-.16	-.15
.00	.00	.00	.00	.00	1.00	.27	.23	.14	.14	.06	.15	-.05	-.17
.00	.00	.00	.00	.00	.00	1.00	1.00	.21	.08	.24	.07	.14	.02
.00	.00	.00	.00	.00	.00	.00	.00	.21	.09	.22	.22	.05	.11
.00	.00	.00	.00	.00	.00	.00	.00	1.00	.22	.07	.23	.05	.11
.00	.00	.00	.00	.00	.00	.00	.00	.00	1.00	.29	.21	.31	.25
.00	.00	.00	.00	.00	.00	.00	.00	.00	.00	1.00	.28	.08	.25
.00	.00	.00	.00	.00	.00	.00	.00	.00	.00	.00	1.00	.35	.13
.00	.00	.00	.00	.00	.00	.00	.00	.00	.00	.00	.00	1.00	.38
.00	.00	.00	.00	.00	.00	.00	.00	.00	.00	.00	.00	.00	1.00

EIGENVALUES	ICOUNT#	1	2	3	4	5	6	7	8	9	10	11	12
2.45	.37	2.20	.43	1.33	1.27	1.09	.96	.85	.76	.50	.70	.53	.56

EIGENVECTORS													
.26	-.18	.20	-.13	.29	.16	.43	-.18	.35	-.17	.12	-.32	-.12	.48
.24	.17	.31	.33	-.24	.17	.37	.14	.33	.32	-.27	.06	-.34	-.24
.11	-.00	.36	-.17	-.31	-.40	.15	-.18	.10	-.15	.55	.11	-.15	-.37
.08	-.02	.38	.08	.26	-.42	.02	.21	-.05	-.04	-.47	.33	-.46	.10
.02	-.05	.42	-.30	.13	.10	-.38	.32	.12	-.38	.02	.14	.52	.06
.09	-.05	.38	.34	-.14	.14	-.45	-.31	.05	.37	.24	.15	-.08	.40
.16	.31	.33	-.13	.12	.08	.14	-.62	-.42	-.12	-.28	-.09	.02	-.10
.19	-.28	.27	-.10	.01	.18	.35	.40	-.57	.30	.24	-.03	.19	.07
.32	.13	.20	.34	-.33	.11	.07	.24	-.01	-.35	.24	-.62	-.13	.08
.34	.08	.09	-.39	.23	-.31	-.07	.03	.32	.54	-.06	-.36	.06	-.10
.32	-.28	.10	.39	.52	.25	-.01	-.07	.18	-.14	.14	.02	-.10	-.49
.35	.37	.05	-.34	-.19	.51	.09	.12	.24	-.07	-.02	.26	-.42	-.00
.43	-.61	-.06	-.09	-.37	-.11	.18	-.22	.18	-.09	-.30	.20	.16	.10
-.38	.39	-.14	.25	.20	-.31	.31	.07	.08	-.09	.27	.31	.30	.33

(PLATE 8)

Output from CORMAT; Regressor data requesting 80% variance accounted for. The regressand output remains the same.

PRINCIPLE COMPONENTS

NUMBER OF ROWS= 9 NUMBER OF COLUMNS= 36

ICOUNT= 3

-1.94	1.98	-1.55	1.00	-1.53	-1.37	.82
.04	2.26	1.34	1.04	-.63	1.13	1.77
.46	2.12	1.49	-1.68	-.51	-1.20	-1.70
.34	1.66	-1.31	-1.71	.15	1.41	-.33
.39	1.52	-.68	.04	2.39	1.09	-.23
-.32	.88	.70	-.07	2.91	-1.19	1.19
-.79	.68	-.95	.93	-.08	-2.46	.15
-.60	.62	.55	1.77	-.81	1.46	.76
-1.39	.39	2.46	-1.21	.38	.59	-.28
-1.78	.40	-1.17	-1.97	.49	.37	.03
-.71	1.24	-1.79	1.47	1.08	.05	1.61
-.40	1.24	1.64	2.07	1.07	.31	-.64
-.43	1.12	1.40	-.26	-.85	-1.71	-1.62
.00	1.35	-1.18	-.10	-2.35	.59	-.78
1.11	1.78	.37	.20	-.53	1.52	-.01
1.81	1.66	.50	-.99	-.05	-.86	1.53
2.21	1.33	-1.02	-.68	-.61	-1.21	-.23
2.81	.92	-.53	.55	-.26	.92	.17
2.95	.25	.93	-.36	.53	-.03	.31
1.93	-.75	-1.17	-1.46	.20	-.67	.29
1.83	-1.19	-1.18	-.34	.59	.11	-.39
1.75	-1.51	-.21	-.89	.91	.09	.16
1.63	-1.83	.35	1.06	-.30	-.13	1.15
1.40	-2.16	.88	.09	-.73	.02	1.09
.97	-2.33	.10	-.97	-.64	.12	-.12
.51	-2.33	-1.11	-.27	.07	1.07	-.01
.10	-2.11	-.36	.64	.41	-.60	.98
-.19	-1.96	.16	.32	-.74	-1.49	.15
-.54	-1.83	.12	.60	-1.66	-.20	-.88
-.58	-1.54	.43	-.37	-.84	1.42	.68
-1.60	-1.59	.39	-1.32	1.08	1.14	1.32
-1.73	-1.13	-1.07	-.29	1.42	-.69	-.41
-1.30	-.51	-1.78	2.32	.50	-.36	.96
-2.16	-.54	2.16	1.39	-.10	.35	.08
-3.23	-.44	1.25	-1.75	-.43	-.41	.50
-3.53	.39	-2.18	-.57	-.63	.30	-.44
						-.28
						-.86
						.69
						-.37
						-.09
						.61
						-.33
						.43
						-.63
						.82
						-.41
						.33
						.80
						1.59
						-.97
						-.41
						1.59
						-.88
						.15
						-.41
						1.63
						-.27
						.10
						-.98
						1.00
						-1.72
						-.41
						.97
						1.59
						-.88
						.68
						1.59
						-.41
						.96
						1.42
						-.69
						.08
						.50
						-.36
						.61
						-.33
						1.23
						-.37
						.09
						-.46
						-.28
						.55

AMOUNT OF VARIANCE ACCOUNTED FOR 82 PERCENT NUMBER OF EIGENVALUES = 9

(PLATE 8 CONTINUED)

REGRESSION COEFFICIENTS

.01	.11	-.18	.03	-.60	.06	-.82	-.52
-.10	-.24	-.10	.33	-.12	-.32	.31	-.28
.08	.08	.05	-.41	-.12	-.30	-.21	-.14
.08	.06	-.06	-.24	-.07	-.41	.18	-.42
-.04	-.11	.06	.04	-.07	.38	.20	-.44
-.02	.07	.30	-.06	.25	-.23	-.49	.24
-.03	-.33	-.10	-.07	-.18	.34	-.39	.09
-.03	.22	-.11	.06	-.31	-.13	.00	.05
-.01	.09	.11	.17	.10	-.07	-.29	.19
-.09	-.01	.09	.04	-.07	.00	.00	-.01
-.12	.07	-.22	.12	-.14	-.27	.10	-.11
-.04	-.03	.07	-.07	-.10	-.04	.03	-.11
.06	.30	.02	.16	-.09	.14	.06	.01
.07	-.08	.13	.10	.00	.04	.12	-.21

TRANSFER FUNCTION

.49	.11	.04	-.03	-.26	-.02	-.20	.13	-.03	.21	.06	-.03	.04
-.05	.43	.05	.04	.19	-.34	.03	-.29	.09	-.09	.25	.09	.03
.16	-.08	.35	.09	.00	.26	-.36	.01	-.22	-.02	-.09	-.20	.07
-.17	.15	.01	.38	.02	-.14	.08	-.42	-.07	-.04	-.01	-.12	.18
-.08	-.16	.10	.08	-.01	.01	-.13	.24	-.36	-.03	.03	-.04	-.14
-.25	.02	.03	.02	.42	.08	.03	-.14	.25	-.17	-.17	-.07	-.20
.10	-.28	-.01	.01	-.05	.41	.09	-.16	.07	.11	-.19	-.14	-.08
-.07	.15	-.19	-.04	.06	-.04	.44	-.00	-.16	-.05	.03	-.22	-.16
.05	-.08	.07	-.21	.00	.12	-.06	.47	.03	-.11	-.08	.02	-.23
.05	.09	-.04	.06	.02	-.08	.12	-.03	.38	.03	-.11	-.05	.07
.31	-.00	-.07	-.02	-.14	.01	-.12	.07	.00	.23	.05	-.08	.01
.03	.23	.06	-.05	.14	-.20	-.07	.06	-.05	.03	.32	.18	.03
.14	.10	.23	.05	.08	.12	-.21	-.09	.13	.04	.02	.25	.17
.14	.10	.04	.20	-.15	.00	-.21	-.21	-.06	.14	.07	.03	.25

REGRESSION BASED ESTIMATE OF REGRESSAND

-.33	.78	-.86	-.12	-.21	1.76	-.84	-.31	-.24	-.61	.70	-.27	-1.01
.13	.24	.09	-.89	.25	.09	1.03	-.37	.99	.03	-.40	.39	.51
-.57	.43	-.36	.13	-.99	-.27	-.48	-.18	.18	-.25	-.08	-.22	-.30
.32	-.50	.24	-1.19	-.68	-.43	.02	-.21	-.92	-.17	-.32	.03	-.73
-.85	1.21	.62	.83	.21	1.76	.92	.17	-.25	-.20	1.05	-.21	1.26
-.36	-.84	.60	-.30	.38	-.29	-.07	.40	.34	-.08	-.53	1.02	.58
.31	.25	.07	.10	.07	-.25	-.20	-.55	-.17	-.52	.60	.69	.29
.18	.24	-.21	.24	-.27	-.15	.37	.86	-.42	-.13	.05	-.38	.92
-1.03	-.16	.40	.67	-.15	-.14	-.63	-.08	1.24	-.87	1.02	-.06	.76
.46	.26	-.28	.33	-.18	-.63	.28	-.16	.58	.56	-.22	-.48	-.01

(PLATE 9)

Output from REGRESS, using X<sub>ps</sub> (80%) and Y<sub>NS</sub> (100%) before F-test rejection has been employed.

SUM OF SQUARES DUE TO REGRESSION

38.31	-1.92	5.64	-1.28	1.90	8.66	6.66	6.82	3.24	-2.78	2.38	1.61	.89	-1.33
-1.92	16.56	10.72	8.24	4.49	-7.75	-2.02	-4.4	-5.97	1.55	4.47	1.39	-4.02	.82
5.64	10.72	18.40	7.01	-2.39	5.47	5.61	-3.31	-2.33	2.49	-1.67	.83	-1.32	-.02
1.28	8.24	7.01	-9.73	5.37	6.82	6.05	1.90	-2.66	2.18	2.16	1.06	-.97	-.73
1.90	4.49	-2.39	-5.37	16.11	-1.12	2.14	-2.69	-2.93	2.00	.06	1.74	-1.27	3.89
8.66	-7.75	5.47	.62	-1.12	19.18	-3.56	-3.51	5.97	-1.95	-3.19	3.04	-3.26	1.69
6.66	-2.02	5.61	-6.05	2.14	-3.56	15.90	-2.05	-4.3	4.77	-2.56	-2.36	1.78	-1.80
6.82	-4.4	-3.31	1.90	-2.69	-3.51	-2.05	7.08	.13	-1.35	4.64	.80	-.62	-1.84
3.24	-5.97	-2.33	-2.66	-2.93	5.97	-4.3	.13	4.81	-1.35	-7.2	.18	-.30	-.29
-2.78	1.55	2.49	-2.18	2.00	4.77	4.77	-1.35	-2.0	4.68	.31	-.18	.14	.27
2.38	4.47	-1.67	2.36	.06	-3.19	-2.56	4.64	-7.2	.31	7.37	-.51	-2.12	-1.10
1.61	1.39	.83	1.04	1.74	3.04	1.78	4.64	.18	-.18	-.51	2.47	-.96	.90
.89	-4.02	-1.32	-.97	-1.27	-3.26	1.78	-.62	-.30	-.18	-2.12	-.96	9.11	-.43
-1.33	.82	-.02	-.73	3.89	-1.80	-1.80	-1.84	-.29	.27	-1.10	.90	-.43	3.84

MEAN SQUARE RESIDUAL

.73	.05	-.16	.04	-.05	-.24	-.24	-.19	-.09	.08	-.07	-.04	-.02	.04
.05	1.14	-.30	-.23	-.12	.02	.06	.01	.17	-.04	-.12	-.04	-.11	-.02
-.16	-.30	1.01	-.19	.07	-.15	-.16	.09	.06	-.07	.05	-.02	.04	.00
.04	-.23	1.01	1.06	.15	-.02	.17	-.05	.07	.06	-.07	-.03	.04	.02
-.05	-.12	.07	.15	.77	.00	-.06	.10	-.17	-.06	-.00	-.05	.04	-.11
-.24	.02	-.15	-.02	.00	.60	.10	.10	.08	-.05	.07	-.08	.04	-.04
-.24	.06	-.16	.17	-.06	.10	.62	.06	.01	-.13	.07	-.07	-.05	.05
-.19	.01	.09	-.05	.07	.10	.06	.62	-.00	.04	-.13	-.02	-.02	.05
-.09	.17	.06	-.07	.08	-.17	.01	-.00	-.00	.01	.02	-.00	.01	.01
.08	-.04	-.07	.06	-.06	.05	-.13	.04	.01	.51	-.01	.00	-.00	-.01
-.07	-.12	.05	-.07	-.00	.09	.07	-.13	.02	-.01	.37	.01	.06	.03
-.04	-.04	-.02	-.03	-.05	-.08	.07	-.02	-.00	-.01	.01	.38	.03	-.03
-.02	.11	.04	.03	.04	-.09	-.05	.02	-.00	.00	.06	.03	.13	.01
.04	-.02	.00	.02	-.11	-.04	.05	.05	.01	-.01	.03	-.03	.01	.22

MULTIPLE CORRELATIONS COEFFICIENTS SQUARED

.59	.29	.34	.20	.37	.47	.42	.24	.18	.20	.35	.15	.67	.33
-----	-----	-----	-----	-----	-----	-----	-----	-----	-----	-----	-----	-----	-----

F RATIO ( 8, 27) DEG

4.89	1.36	1.71	.86	1.97	2.99	2.41	1.07	.72	.86	1.85	.61	6.78	1.63
------	------	------	-----	------	------	------	------	-----	-----	------	-----	------	------

UNBIASED RESIDUALS

.98	.07	-.21	.05	-.07	-.32	-.32	-.25	-.12	.10	-.09	-.06	-.03	.05
.07	1.52	-.40	-.31	-.17	.03	.07	.02	.22	.06	-.17	-.05	.15	-.03
-.21	-.40	1.35	.09	-.20	-.20	-.21	.12	.09	-.09	.06	-.03	.05	.00
.05	-.31	-.26	1.42	.20	-.02	.22	-.07	.10	.08	-.09	-.04	.04	.03
-.07	-.17	.09	-.20	1.02	.00	-.08	.10	.11	-.07	-.00	-.06	.05	-.14
-.32	.03	-.20	-.02	.00	.80	.13	.13	-.22	.07	.12	-.11	.12	-.06
-.32	.07	-.21	.22	-.08	.13	.82	.08	.02	-.18	.09	-.07	.07	.07
-.25	.02	.12	-.07	.10	.08	.08	.83	-.00	.05	-.17	-.03	-.02	.07
-.12	.22	.09	.10	-.22	.02	.02	-.00	.83	.01	.03	-.01	.01	.01
.10	-.06	-.09	.08	-.07	.07	-.18	.05	.01	.68	-.01	.01	-.01	-.01
-.09	-.17	.06	-.09	-.00	.12	.09	-.17	.03	-.01	.50	.02	.08	.04
-.06	-.05	-.03	-.04	-.06	-.11	.09	-.03	-.01	.01	.02	.04	.04	-.03
-.03	.15	.05	.04	-.05	.12	-.07	.02	.01	-.01	.08	.04	.17	.02
.05	-.03	.00	.03	-.14	-.06	.07	.07	.01	-.01	.04	-.03	.02	.29

(PLATE 9 CONTINUED)

VARIANCE OF REGRESSION COEFFICIENTS-DIAGONAL

MATRIX NUMBER .01	1	.02	.03	.03	.04	.04
MATRIX NUMBER .02	2	.03	.04	.05	.06	.06
MATRIX NUMBER .02	3	.03	.04	.04	.05	.05
MATRIX NUMBER .02	4	.03	.04	.04	.05	.06
MATRIX NUMBER .01	5	.02	.03	.03	.04	.04
MATRIX NUMBER .01	6	.02	.02	.02	.03	.03
MATRIX NUMBER .01	7	.02	.02	.02	.03	.03
MATRIX NUMBER .01	8	.02	.02	.02	.03	.03
MATRIX NUMBER .01	9	.02	.02	.02	.03	.03
MATRIX NUMBER .01	10	.02	.02	.02	.03	.03
MATRIX NUMBER .01	11	.01	.01	.01	.02	.02
MATRIX NUMBER .01	12	.01	.01	.01	.02	.02
MATRIX NUMBER .00	13	.00	.00	.00	.01	.01
MATRIX NUMBER .00	14	.00	.01	.01	.01	.01

CONFIDENCE INTERVAL OF ESTIMATE

.63	.52	.61	1.38	.18	.04	.72	.60	.27	.36	.21	.25	.10	.40
1.09	.89	1.04	2.36	.31	.08	1.23	1.03	.47	.62	.36	.42	.17	.68
1.56	1.28	1.49	3.39	.45	.11	1.77	1.48	.68	.89	.52	.61	.24	.98
1.32	1.09	1.27	2.87	.38	.09	1.50	1.25	.57	.75	.44	.51	.21	.83
.69	.56	.66	1.49	.20	.05	.78	.65	.30	.39	.23	.27	.11	.43
1.21	.99	1.16	2.63	.35	.09	1.37	1.15	.52	.69	.40	.47	.19	.76
1.30	1.07	1.24	2.82	.37	.09	1.47	1.23	.56	.74	.43	.50	.20	.81
1.01	.83	.97	2.19	.29	.07	1.15	.96	.44	.58	.33	.39	.16	.63
.62	.51	.59	1.34	.18	.04	.70	.59	.27	.35	.20	.24	.10	.39
1.05	.86	1.01	2.29	.30	.07	1.19	1.00	.46	.60	.35	.41	.16	.66

(PLATE 9 CONTINUED)

CORRECTED BY F-TEST REJECTION

REGRESSION COEFFICIENTS

-.01	.01	.11	-.18	.03	-.60	.06	-.82	-.52
.00	.00	.00	.00	.00	.00	.00	.00	.00
.00	.00	.00	.00	.00	.00	.00	.00	.00
.00	.00	.00	.00	.00	.00	.00	.00	.00
.00	.00	.00	.00	.00	.00	.00	.00	.00
-.04	-.01	.07	.30	-.06	.25	-.23	-.49	-.44
-.02	.03	-.33	-.10	-.07	-.18	.34	-.39	.24
.00	.00	.00	.00	.00	.00	.00	.00	.00
.00	.00	.00	.00	.00	.00	.00	.00	.00
.00	.00	.00	.00	.00	.00	.00	.00	.00
.00	.00	.00	.00	.00	.00	.00	.00	.00
.00	.00	.00	.00	.00	.00	.00	.00	.00
.06	.30	-.01	.02	.16	-.09	.14	.06	.01
.00	.00	.00	.00	.00	.00	.00	.00	.00

TRANSFER FUNCTION

.22	-.10	.12	-.03	-.00	-.06	.22	-.19	.14	-.03	.07	-.10	.04	-.01
-.16	.28	.04	.11	.03	.18	-.24	.11	-.22	.03	-.10	.18	.07	.04
.17	.01	.29	.04	-.02	.06	.16	-.36	-.00	-.03	-.03	-.04	.22	.07
-.08	.14	-.08	.08	-.11	.10	-.07	.22	-.22	.17	-.03	-.02	-.09	.02
.06	-.06	.09	-.06	.16	-.07	-.04	-.17	.21	-.19	.02	.10	.10	-.03
-.05	.19	.07	.13	-.15	.18	-.04	.06	-.30	.19	-.06	-.03	.03	.08
.22	-.10	.01	-.04	.11	-.14	.18	-.02	.28	-.10	.11	-.03	-.06	-.09
-.04	.17	-.13	.05	-.02	.06	-.08	.33	.24	.12	-.00	.04	-.15	-.04
.21	-.11	-.01	.07	.06	-.13	.19	-.01	.24	-.06	.10	-.07	-.08	-.08
.01	.09	.01	.03	.02	.04	-.04	.05	-.04	.01	-.01	.05	.00	-.00
.12	-.11	-.09	-.04	.00	-.11	.13	.07	.15	-.00	.08	-.09	-.12	-.06
-.02	.14	.05	.05	.04	.08	-.08	.04	-.06	.00	-.03	.09	.03	.01
.15	.01	.23	.03	-.01	.04	.15	-.27	.01	-.03	.01	-.03	.16	.05
-.03	.13	-.02	.05	-.00	.07	-.06	.13	-.09	.05	-.02	.05	-.03	-.01

REGRESSION BASED ESTIMATE OF REGRESSAND

.04	.31	.33	.76	-.03	.18	.58	.38	-.25	.57	.41	-.45	-1.36	-.61
.19	.08	-.45	-.48	.09	-.45	-.04	1.04	-.79	.78	.03	-.05	.51	.33
-.35	.32	-.18	-.26	-.38	-.32	-.09	.19	-.06	.22	.12	.29	-.01	.36
.09	.14	.23	.11	-.08	-.48	-.31	-.23	-.24	.32	-.05	-1.07	-.14	.18
.12	.39	.18	.19	-.11	-.08	.19	.52	.43	.35	-.02	.43	-.24	.55
-.42	-.39	-.11	-.40	.13	.44	-.08	-.08	-.05	.22	-.17	-.05	.93	.52
.11	.33	.46	.13	-.18	.60	-.20	.12	.08	-.09	.13	.08	-.03	-.11
.01	.01	.08	-.45	.95	.25	-.01	.19	.28	.20	.42	.00	-.31	.28
-.63	-.16	.15	.16	-.10	-.24	-.02	-.07	-.08	.80	.66	-.55	-.01	.09
.45	.26	-.29	.33	-.29	.02	-.40	-.20	.09	.23	-.09	-.06	.08	.06

(PLATE 10)

Output from REGRESS. Using X<sub>ps</sub> (80%) and Y<sub>Ns</sub> (100%) after F-test rejection has been employed.





VARIANCE OF REGRESSION COEFFICIENTS-DIAGONAL

MATRIX NUMBER	1	.02	.03	.03	.04	.04
MATRIX NUMBER	2	.00	.00	.00	.00	.00
MATRIX NUMBER	3	.00	.00	.00	.00	.00
MATRIX NUMBER	4	.00	.00	.00	.00	.00
MATRIX NUMBER	5	.00	.00	.00	.00	.00
MATRIX NUMBER	6	.02	.02	.02	.03	.03
MATRIX NUMBER	7	.02	.02	.02	.03	.03
MATRIX NUMBER	8	.00	.00	.00	.00	.00
MATRIX NUMBER	9	.00	.00	.00	.00	.00
MATRIX NUMBER	10	.00	.00	.00	.00	.00
MATRIX NUMBER	11	.00	.00	.00	.00	.00
MATRIX NUMBER	12	.00	.00	.00	.00	.00
MATRIX NUMBER	13	.00	.01	.01	.01	.01
MATRIX NUMBER	14	.00	.00	.00	.00	.00

CONFIDENCE INTERVAL OF ESTIMATE

.22	.05	.24	.40	.50	.38	.41	.19	.29	.02	.04	.08	.23	.06
.38	.09	.41	.69	.85	.65	.71	.33	.50	.04	.08	.13	.39	.10
.55	.13	.59	1.00	1.23	.94	1.02	.47	.73	.06	.11	.19	.56	.15
.47	.11	.50	.84	1.04	.80	.86	.40	.61	.05	.09	.16	.47	.13
.24	.05	.26	.44	.54	.41	.45	.21	.32	.02	.05	.08	.25	.07
.43	.10	.45	.77	.95	.73	.79	.36	.56	.04	.08	.15	.43	.12
.46	.10	.49	.83	1.02	.78	.85	.39	.60	.05	.09	.16	.46	.12
.36	.08	.38	.64	.79	.61	.66	.30	.47	.04	.07	.12	.36	.10
.22	.05	.23	.39	.49	.37	.40	.18	.29	.02	.04	.08	.22	.06
.37	.08	.40	.67	.83	.63	.69	.31	.49	.04	.07	.13	.38	.10

PREDICTING METASTASIS OF ENUCLEATED SMALL  
OPHTHALMIC MELANOMAS BY DISCRIMINANT FUNCTION

Walter D. Foster  
Ian W. McLean (Maj, MC, USA)  
Armed Forces Institute of Pathology  
Washington, D. C. 20306

ABSTRACT. Malignant melanomas of the uveal tract of the eye are tumors with a significant risk of metastasis. To reduce this risk, it has been the practice of ophthalmologists, after making a clinical diagnosis of malignant melanoma, to recommend immediate enucleation of the eye. The objective of this study was to search for a criterion by which the risk of metastasis could be estimated.

Over 300 cases of enucleation for small malignant melanomas have been referred to the Ophthalmic Pathology Division of the Armed Forces Institute of Pathology (AFIP) for investigation and research. Of these cases, pathologists recorded 16 characteristics on each of 72 eyes, together with information on whether the tumor had metastasized. Analysis by stepwise discriminant function was employed to suggest which of these characteristics might be predictive of metastasis and the degree of their effectiveness. An unexpected dividend in the use of the discriminant function was the redefinition of some of the characteristics and the review of the original data for others, in a medico-statistical dialog in the refinement of the capability for prediction. The following table shows the degree of success of the analysis for the body of data at hand:

Table 1. Comparison of Classification by Discriminant Function with Actual Behavior in 72 Cases of Small Ophthalmic Melanoma

Actual group	<u>Correct Prediction</u>	<u>Incorrect Prediction</u>
Nonmetastasizing (40)	34	6
Metastasizing (32)	27	5

1. INTRODUCTION. A major ophthalmic problem is concerned with the decision whether to advise enucleation of the eye when a small intraocular melanoma has been discovered. The decision to remove the eye depends heavily upon the risk of metastasis. In the case of small tumors of the choroid, the surgeon is faced with the difficult decision of whether to remove the eye or continue to ob-

serve the lesion until there is greater certainty that it is malignant. The purpose of this research was to discover whether there is a basis for estimating the risk of metastasis.

The Ophthalmic Pathology Division of AFIP has the largest known collection of eyes enucleated for small malignant melanomas--over 300 cases. After defining 15 characteristics as possible predictors of metastasis, pathologists selected 76 tumor-containing eyes enucleated prior to 1945 because all needed data were available; 34 tumors were known to have resulted in metastasis, and 42 patients were free of metastasis at the last known status 7 or more years after enucleation.

Fisher's linear discriminant function was chosen as the statistical function for the classification of these melanomas on the basis of the 15 predictors. Analysis by stepwise discriminant function to order the predictors in terms of their relative predictability was envisioned as a process for identifying the most meaningful set of predictors to be compared with the list of predictors selected by pathologists from medical experience for intraocular melanomas of all sizes.

2. DISCRIMINANT FUNCTION. To define the linear discriminant function,

Let  $X_i$  =  $i$ -th characteristic, e.g., size;  $i = 1 - 15$ ,

Let  $B_i$  = coefficient of  $X_i$  to be estimated.

Set  $Z_1 = \sum B_i X_i$  for the nonmetastasizing melanomas

and  $Z_2 = \sum B_i X_i$  for the metastasizing.

Let  $D = Z_1 - Z_2$  and  $d_i = \bar{X}_{in} - \bar{X}_{im}$  so that

$$D = \sum B_i d_i \quad \text{and} \quad V(D) = \sum \sum B_i B_j a_{ij} = S.$$

For analogy with the univariate case, just as we wish to maximize

$$t = (\bar{X}_1 - \bar{X}_2) / s(1/n_1 + 1/n_2)^{1/2} \quad \text{or its square,}$$

in the discriminant function the  $B_i$  are estimated by maximizing  $D^2/S$ :

$$\frac{\partial D^2/S}{\partial B_i} = 0, \quad \text{whose resulting equations have the solution}$$

$$B_i = (S/D) \sum d_i a^{ij} \quad \text{where } a^{ij} \text{ is an element of the}$$

inverse of the variance-covariance matrix of the  $X_i$ , pooled over the two groups under the assumption of homoscedasticity.

The constant S/D has no meaning as far as the discriminant function is concerned and can be arbitrarily equated to unity for simplicity.

The assumptions for the probability statements implicit in the use of the discriminant function required that the predictor variables be continuous and have a joint multivariate normal distribution and that the variance-covariance matrix for each group be equal. Therefore, the following list of proposed predictors (characteristics) was examined in terms of its marginal distribution properties.

Predictor Number	Predictor	Univariate properties
1	Age	Continuous, approximately normal
2	Duration	Continuous, skewed to right
3	Enucleation date	Continuous, skewed to left
4	Size	Continuous, skewed to right
5	Volume	Continuous, skewed to right
6	Area	Continuous, skewed to right
7	Sex	Two-class, uniform
8	Posterior margin	Nine-class, skewed to right
9	Anterior margin	Nine-class, skewed to right
10	Eye	Two-class, uniform
11	Cell type	Four-class, skewed
12	Pigment	Four-class, skewed to right
13	Fiber	Five-class, skewed to right
14	Scleral extension	Four-class, skewed to right
15	Optic nerve "	Four-class, skewed to right

Three results were immediately obvious. Not only was the assumption of multivariate normality invalid, but it also was clear that the covariance matrices of the two groups, metastasizing and nonmetastasizing, were not equal. Moreover, the additive model was at best a first approximation. Nevertheless, it was felt that an imperfect approach could be tried and judged on its performance. The UCLA BMD program, stepwise discriminant function, was utilized. This program selects as the first predictor and as successive predictors in turn that one for which the likelihood ratio expressed in terms of the F-statistic is a maximum. The advantage of this approach is obvious--the set of predictors is ordered and can be truncated at any point by the experimenter. Further, in this study it offered a comparison of predictors selected in this fashion to those previously selected by the pathologists from experience.

3. MEDICO-STATISTICAL INTERACTIVE DIALOG. The results of our first run with the stepwise discriminant-function program are given in Table 2. It was clear from this run

TABLE 2. PREDICTIVE PARAMETERS SELECTED BY STEPWISE DISCRIMINANT FUNCTION IN MEDICO-STATISTICAL DIALOG

ORDER OF INCLUSION	PRE-ANALYSIS PATHOLOGIST LIST	RUN #1	RUN #2	RUN #3	RUN #4
I	11, CELL TYPE	14	4	14	14
II	4, SIZE	- 2	14	- 1	4
III	12, PIGMENT	4	- 1	9	9
IV	14, SCL. EXT.	- 1	9	12	- 5
V	13, FIBER	- 3	- 5	4	
VI	1, AGE	12	7	16	
VII		9	11		
VIII		- 6	- 2		
IX			12		
FALSE POSITIVE (F+)		5/42	4/41	6/40	7/40
FALSE NEGATIVE (F-)		11/34	8/32	5/32	8/32
TOTAL ERROR		16/76	12/73	11/72	15/72
REVIEW	<p>COMPARED TO PATHOLOGISTS' LIST; RECLASSIFIED CELL TYPE; FOUND AND REMOVED THREE ERRONEOUS CASES; TRIED TO INTERPRET NEGATIVE COEFFICIENTS.</p> <p>COMPARED TO PATHOLOGISTS' LIST; ADDED MITOTIC ACTIVITY (16) AS A PREDICTOR; FOUND AND REMOVED ONE ERRONEOUS CASE; TRIED TO INTERPRET NEGATIVE COEFFICIENTS.</p> <p>CONSIDERED PREDICTORS #1, 2, AND 3 AS ESSENTIALLY ARTIFICIAL; OMITTED PREDICTOR #15.</p>				

N.B.: NEGATIVE SIGNS REFER TO NEGATIVE COEFFICIENTS.

that, of the 15 original predictors, no more than 8 were effective in combination. An astounding finding was the failure of predictor #11, cell type, which was the leading choice by pathologists' experience, to be included in the list of effective predictors. Also unexpected were the negative signs for the coefficients for predictor #2, duration; #1, age; #3, enucleation date; and #6, area. In effect, the data were contradicting the notion that the probability for metastasis increases with increasing age, duration of the melanoma, area of the melanoma, etc. The error rate for false positives, F+, defined as nonmetastasizing cases erroneously classified by the function as metastatic, was 5/42, or .12, while that for false negatives, F-, defined as metastatic cases erroneously classified as nonmetastatic, was 11/34, or .32, for a total error of 16/76, or .21. Our review of these results included a detailed examination of those cases that were misclassified by the discriminant function. This review revealed inconsistent criteria for cell type and three cases that should not have been included in the study.

The second run, with the value for cell type revised by the consensus of three pathologists, selected the predictors in the order shown in Table 2. The review of run #2 found yet another case erroneously included in the original set of data. It was of interest that the refined definition of cell type, predictor #11, was included in the group of meaningful predictors. Only fiber content as a predictor in the pathologists' list failed to be included in the group of meaningful predictors in run #2, although it was noted that age continued to have a negative coefficient. At this point, it was decided to add a 16th predictor, mitotic activity, for the next run.

Run #3, shown in Table 2, did include the new predictor, mitotic activity, but unexpectedly dropped cell type. The total error rate stayed about the same as before despite a slight shift in the F+ and F- rates. Pathologists' opinion did not agree that #1 (age), #2 (duration), and #3 (enucleation date) were physically meaningful and recommended that these as well as #15 (optic nerve extension) be dropped as predictors for the next run.

Run #4 did not discriminate as well as runs #2 and 3. Its overall error rate was 15/72, with F+ as 7/40 and F- as 8/32. It also dropped both cell type and mitotic activity as meaningful predictors. It did continue to show an acceptable level of discrimination.

With these as the results thus far, we reminded ourselves that it has been the thrust of this preliminary paper not so much to list medical findings or implications (which will be reported elsewhere) as to suggest the value of the continuing medico-statistical interactive dialog in the winnowing process of finding and redefining meaningful predictors.

4. CONCLUSIONS. The discriminant-function approach appears to offer considerable promise to serve as a basis for estimating risk probabilities as a help to medical practice in evaluating small ophthalmic melanomas. Future investigation in this specific direction will include (1) the use of this discriminant function on a new population to estimate true error rates and to improve overall predictive ability, (2) the reformulation of the prediction function to allow greater flexibility than offered by the linear terms, such as "product" or "reciprocal," or special relationships among the variables, and (3) possible use of transformations toward achieving normality.

The opinions or assertions contained herein are the private views of the authors and are not to be construed as official or as reflecting the views of the Department of the Army or the Department of Defense.



## FORECASTING MODELS FOR MOSQUITO POPULATION BEHAVIOR

Stephen Smeach and Chris P. Tsokos  
Department of Mathematics  
University of South Florida  
Tampa, Florida 33620

ABSTRACT. The object of this paper is to develop statistical models to forecast mosquito densities up to a specific desired time in advance.

It is shown that the mosquito series is a non-stationary stochastic realization. A procedure is presented in modeling the mosquito densities for the purpose of forecasting one, two, three. . . ., k days ahead. Autoregressive, moving average and mixed autoregressive-moving average models have been utilized for the purpose of predicting mosquito density behavior.

In addition, the technique of utilizing the formulated models in a simulation study to determine the influence of several pesticide application strategies is briefly discussed.

1. INTRODUCTION. Aside from the nuisance factor associated with the presence of mosquitos in the human environment, it is of interest to develop control strategies for mosquito populations since they serve as essential links in the life cycles of a number of human parasites. The incidence of such parasites can be controlled by reducing the population density of their mosquito vectors. Control techniques can take the form of pesticide spraying strategies and alteration of the mosquito larval habitats. The development of accurate statistical models to predict future mosquito densities can be used to advantage by scientists studying control of mosquito-related diseases. Such statistical models could be used to simulate population density behavior under various control strategies and hence serve as an evaluation of control strategies, independent of field tests.

In the present investigation, statistical models are formulated to predict mosquito population densities up to four days in advance. The procedures used are those developed by C.P. Tsokos [ 2 ] for use in formulating forecasting models from non-stationary time series. The data used in this investigation consists of three years of light-trap capture data of adult female mosquitos (*Culex tarsalia*) collected at two day intervals from light trap stations in Malvern, Iowa during 1969, 1970 and 1971. Hacker, Scott and Thompson [ 1 ] have analyzed this data using a somewhat different approach. Professor Thompson discussed their investigation with the present authors and kindly provided the data for our independent analysis.

We shall be concerned with an important class of statistical models, *viz*, the *autoregressive process*, the *moving average process* and the *mixed autoregressive-moving average process*. These processes have been widely used for describing

stationary time series (i.e., those time series that are in statistical equilibrium about a constant mean level). However, much biological data is non-stationary. One can transform non-stationary data in such a manner that it can be treated as a stationary series. Such transformations consist of applying an appropriate filter to the observed time series to "filter out" non-stationary components. In the present investigation, applications of first or second difference filters remove the non-stationary components of the data. Once we have obtained a model for the filtered, stationary series, we must employ the appropriate "backward" filter to replace the non-stationary components. The result will be a model that can be used to obtain forecast values of the original non-stationary time series.

In section 2, the autoregressive, moving average and mixed processes are defined and a procedure for obtaining the "best" statistical model among them is explained in greater detail. In section 3, this procedure is applied to a smoothed-data version of the mosquito population density data and forecasting models are developed. The smoothing procedure is that employed by Hacker et. al. [ 1 ]. In section 4, the procedure developed in section 2 is applied to the original, non-smoothed mosquito population data and forecasting models are developed. Finally, in section 5 we discuss the approach used in this investigation as compared to the approach used by Hacker et.al. and describe further research being contemplated in this area.

2. PROCEDURE. A discrete m-order autoregressive process derived from a purely random process is given by

$$X_t - \mu = \alpha_1(X_{t-1} - \mu) + \alpha_2(X_{t-2} - \mu) + \dots + \alpha_m(X_{t-m} - \mu) + Z_t \quad (2.1)$$

where  $X_t$  is the autoregressive series;  $\alpha_1, \alpha_2, \dots, \alpha_m$  are parameters of the process; and  $\mu$  is the expected value of the series  $X_t$ . Such a process assumes that the current value  $X_t$  of a series can be expressed as a linear sum of past values plus an independent error term  $Z_t$ , not connected with the past.

A finite moving average process of order q is given by

$$X_t - \mu = Z_t - \beta_1 Z_{t-1} - \dots - \beta_q Z_{t-q} \quad (2.2)$$

where  $X_t$  is the moving average series;  $\beta_1, \beta_2, \dots, \beta_q$  are parameters of the process; and  $\mu$  is the expected value of the series. This process is interpreted as a weighted sum of a random series,  $Z_t$ .

A mixed autoregressive-moving average process of order (m, q) is given by

$$X_t - \mu = \alpha_1(X_{t-1} - \mu) + \dots + \alpha_m(X_{t-m} - \mu) + Z_t - \beta_1 Z_{t-1} - \dots - \beta_q Z_{t-q} \quad (2.3)$$

where the value of q is independent of the value of m and all other symbols are as defined above.

The procedure used in the present investigation to determine an appropriate statistical time series model is that procedure developed by Tsokos [ 2 ] and is summarized below:

- (i) *Test the original series for stationarity.* A trend test such as Kendall's  $\tau$  is used to test for stationarity. If the original series fails this test, a first difference filter is applied to the original series to create a new series. The testing procedure is repeated and first difference continue to be applied as necessary until a time series is obtained that passes the stationarity test. A second order difference filter is usually sufficient to filter out non-stationary components.
- (ii) *Determine the "best" statistical time series model.* Using the time series obtained in step (i) a computerized searching procedure is initiated to determine the model and its order from among the models discussed above that best fits the data. The criterion for selecting the best model for the filtered series is based upon estimates of residual variances. One proceeds by estimating the parameters of the different models for different orders. The residual variance estimates are then computed and recorded against the orders of the processes. The minimum residual variance will correspond to the order and type of process which best fits the filtered series.
- (iii) *Apply an appropriate backward filter.* If the original time series were non-stationary, then the model chosen under step (ii) was appropriate for the filtered, stationary series. Hence, at this step a backward filter is applied to replace the non-stationary components. For example, if a first difference filter,  $y_t = x_t - x_{t-1}$ , had been applied to the original series and the appropriate model for the filtered series had been of order (1, 1) then the model has the form

$$y_t - \hat{\mu} = \hat{\alpha}_1 (y_{t-1} - \hat{\mu}) + z_t - \hat{\beta}_1 z_{t-1} \quad (2.4)$$

where  $\hat{\mu}$ ,  $\hat{\alpha}_1$ , and  $\hat{\beta}_1$  are estimates of the parameters based upon the filtered series (see Tsokos [ 2 ]). Written in terms of the  $X_t$ 's equation (2.4) becomes

$$X_t = (1 - \hat{\alpha}_1)\hat{\mu} + (1 + \hat{\alpha}_1)X_{t-1} - \hat{\alpha}_1 X_{t-2} + z_t - \hat{\beta}_1 z_{t-1} \quad (2.5)$$

the process of going from equation (2.4) to equation (2.5) is called "applying the appropriate backward filter". It is equation (2.5) that is then used in step (iv) to forecast future values of the  $X_t$  process.

(iv) Forecast values of the original time series  $\ell$ -days ahead. We desire to forecast a value  $x_{t+\ell}$ ,  $\ell \geq 1$  when we are currently at time  $t$ . For example, as discussed in Tsokos, the generalized mixed model under the influence of a first difference filter has minimum variance  $\ell$ -day ahead forecast given by

$$\begin{aligned} \hat{X}_t(\ell) = & \phi_0 + \phi_1 X_{t+\ell-1} + \dots + \phi_{m+1} X_{t+\ell-m-1} \\ & - \hat{\beta}_1 Z_{t+\ell-1} - \dots - \hat{\beta}_q Z_{t+\ell-q} \end{aligned} \quad (2.6)$$

where  $\hat{X}_t(\ell) = E_t[X_{t+\ell}]$ , i.e., the expected value, at time  $t$ , of  $X_{t+\ell}$ . The constants  $\phi_i$  are functions of  $\hat{\mu}$  and the  $\hat{\alpha}_i$ 's; the  $\hat{\beta}_i$ 's are defined previously; and  $Z_t = X_t - \hat{X}_{t-1}$  (1). Due to the recursive property of the mixed, autoregressive-moving average process, when we forecast with a lead  $\ell \geq 2$ , our forecast is dependent upon the previous forecasted value(s).

In addition to the procedures discussed above, one could proceed to compute confidence intervals for forecasted values and to employ updating methods for use in the model as new time series observations are obtained. These techniques are not discussed here but are well documented in the paper by Tsokos.

3. TIME SERIES MODELS FOR THE SMOOTHED DATA. Because of the (apparent) high noise level in the raw light trap data, Hacker et.al. [ 1 ] smoothed the data using a cubic-spline-integration method that is described in their paper. Figures 1 through 3 below are graphs of the original population data (solid lines) and the smoothed data (dotted lines) for the year 1969, 1970 and 1971 respectively, collected during the months May through October.

Figures 4 through 6 show the smoothed data (solid line) and the 4-day ahead forecast values (dotted line) for each of the years 1969, 1970, 1971. As can be seen by inspection, the agreement is very good except for the lag between the two curves which is characteristic for time series work. All three years data required first difference filters for stationarity and were best fitted by order 3 moving average processes. The models for 1969, 1970, 1971 are presented as equations (3.7), (3.8) and (3.9), respectively.

$$\hat{X}_t = .0083 + (.9)Z_t - (.1)Z_{t-1} - (.5)Z_{t-2} \quad (3.7)$$

$$\hat{X}_t = -.0278 + (.9)Z_t + (.2)Z_{t-1} - (.3)Z_{t-2} \quad (3.8)$$

$$\hat{X}_t = .0431 + (.9)Z_t + (0.0)Z_{t-1} - (.3)Z_{t-2}$$

ORIGINAL TIME SERIES

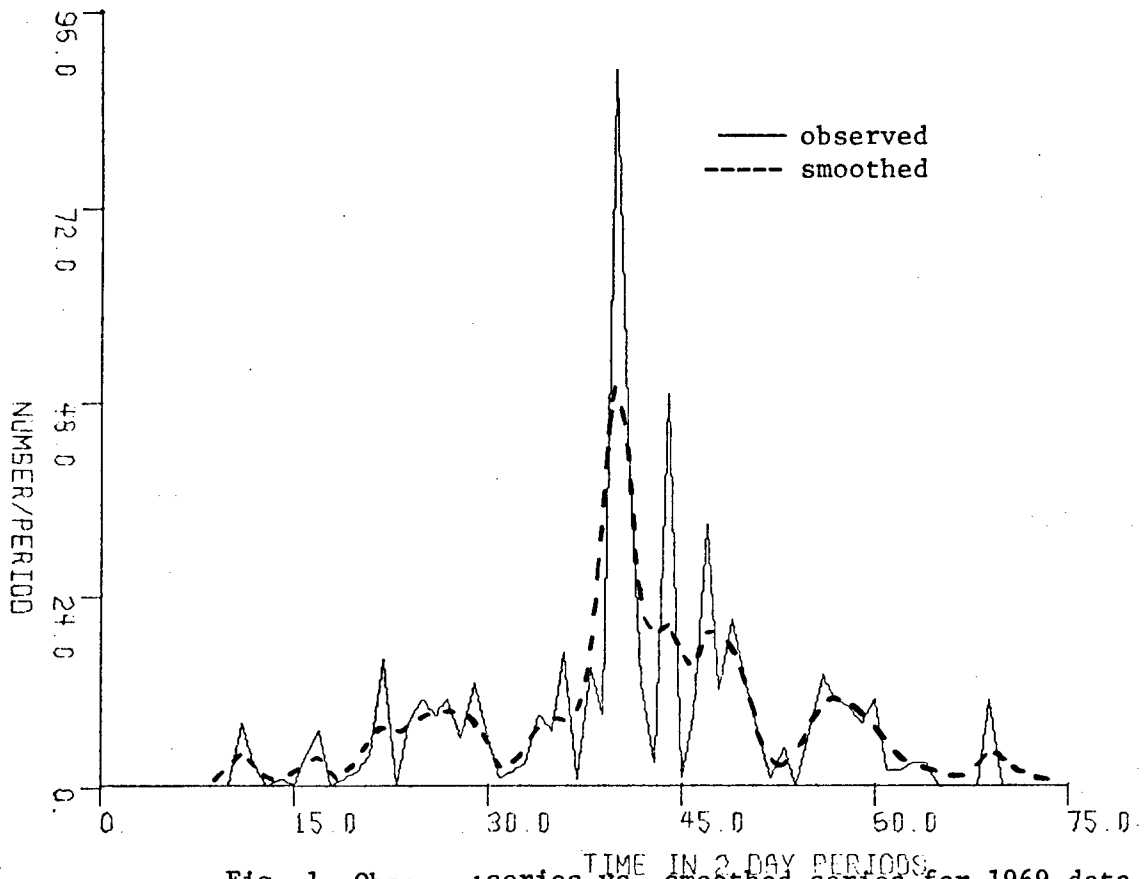


Fig. 1. Observed series vs. smoothed series for 1969 data.

ORIGINAL TIME SERIES

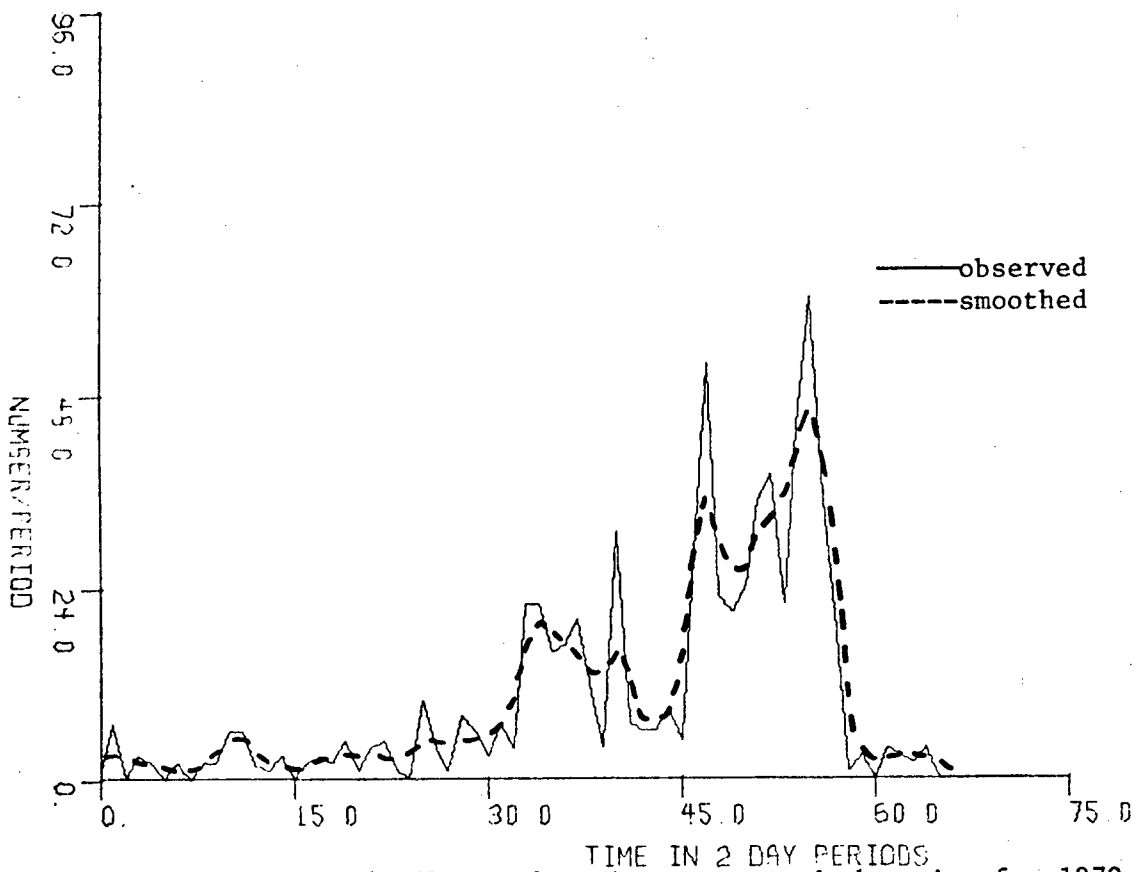


Fig. 2. Observed series vs. smoothed series for 1970 data

ORIGINAL TIME SERIES

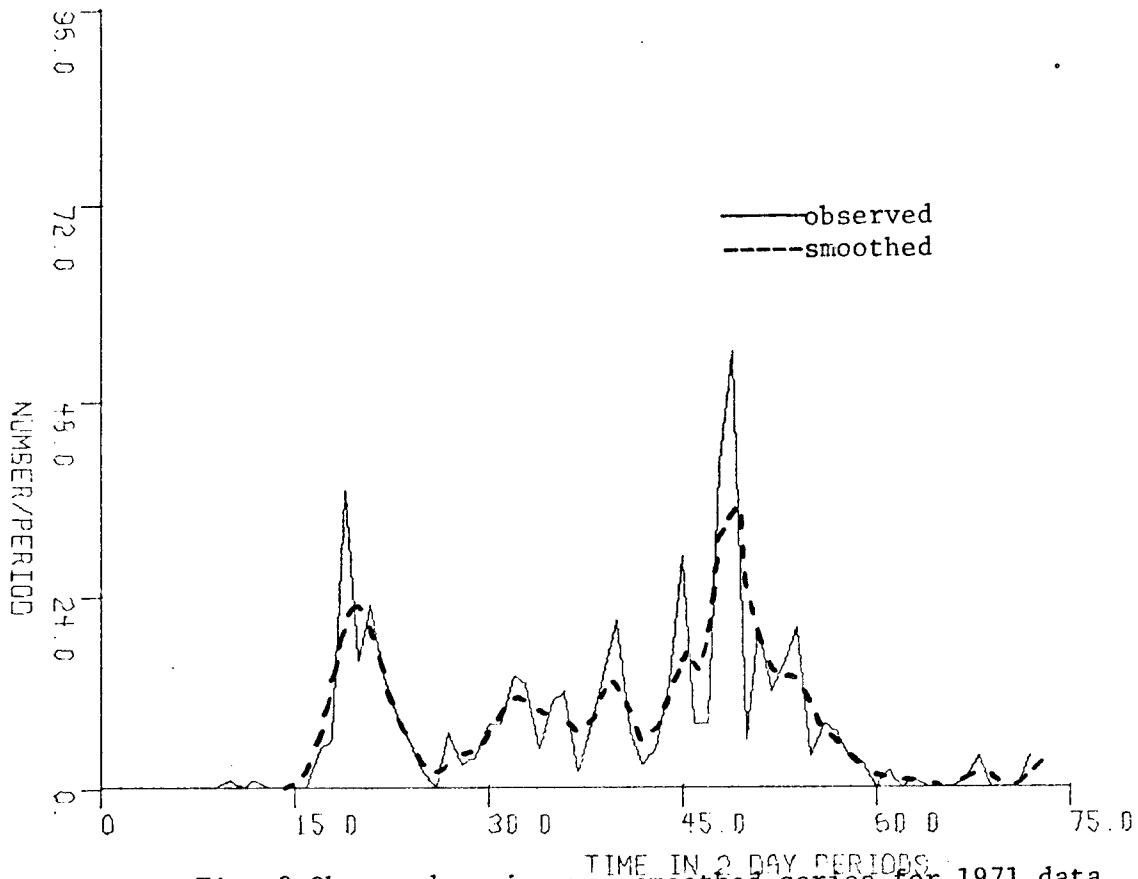


Fig. 3 Observed series vs. smoothed series for 1971 data.

ORIGINAL TIME SERIES

$$\hat{x}_t = (.0083) + (.9)z_t - (.1)z_{t-1} - (.5)z_{t-2}$$

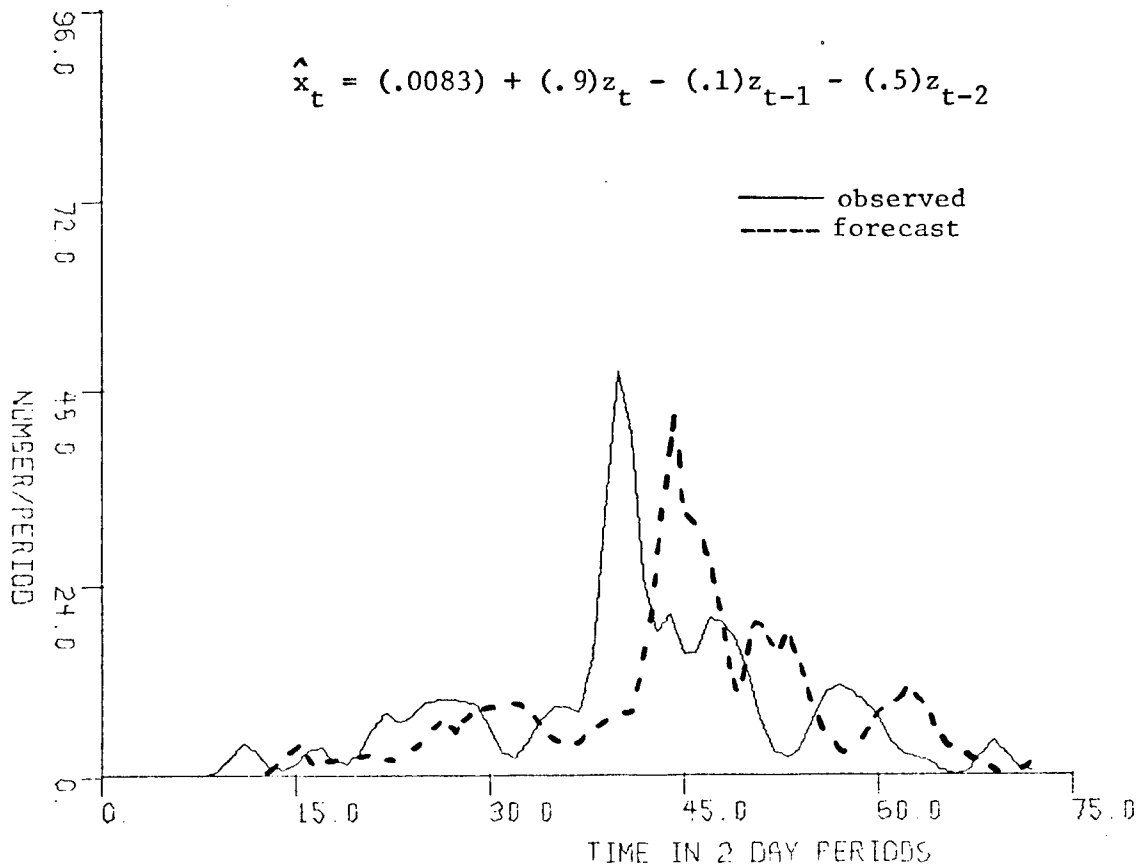


Fig. 4 Observed as 4-day ahead forecast series for 1969 smoothed data.

ORIGINAL TIME SERIES

$$\hat{x}_t = -(.0278) + (.9)z_t + (.2)z_{t-1} - (.3)z_{t-2}$$

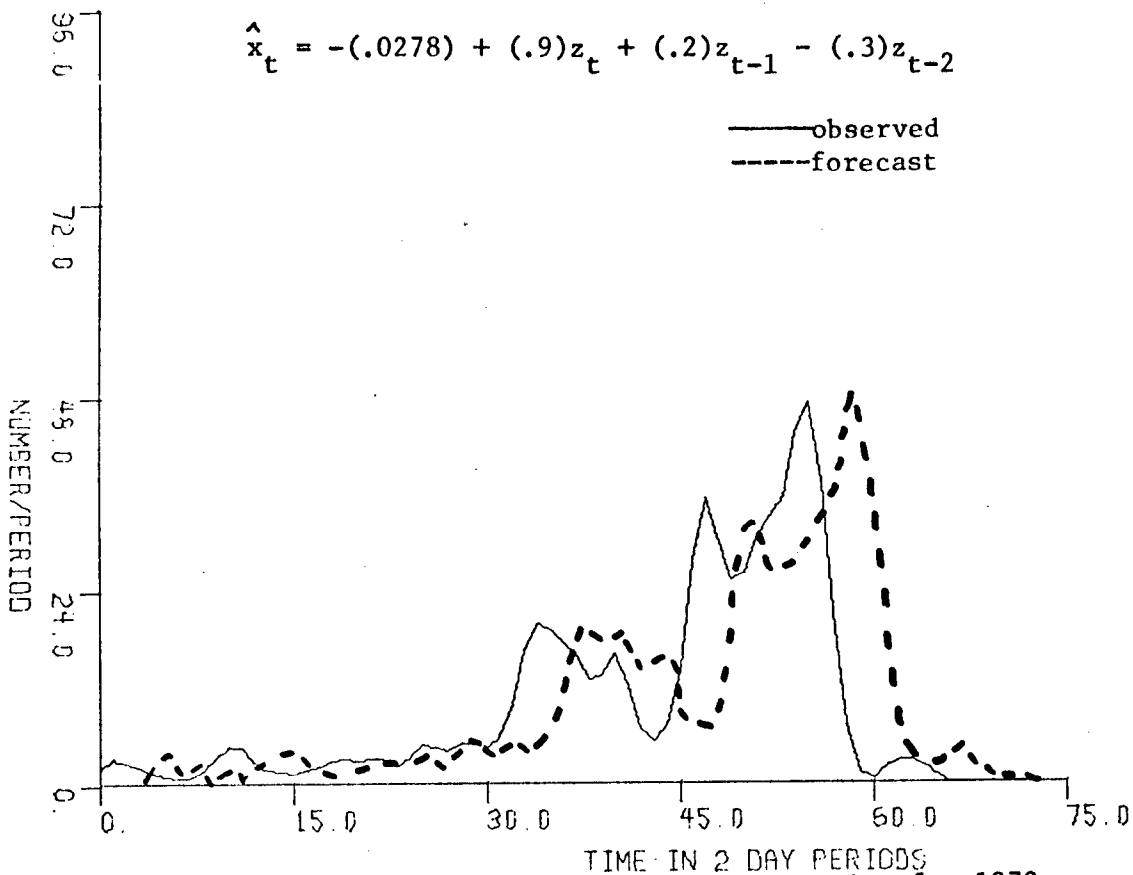


Fig. 5 Observed vs. 4-day ahead forecast series for 1970 smoothed data.

ORIGINAL TIME SERIES

$$\hat{x}_t = (.0431) + (.9)z_t - (.3)z_{t-2}$$

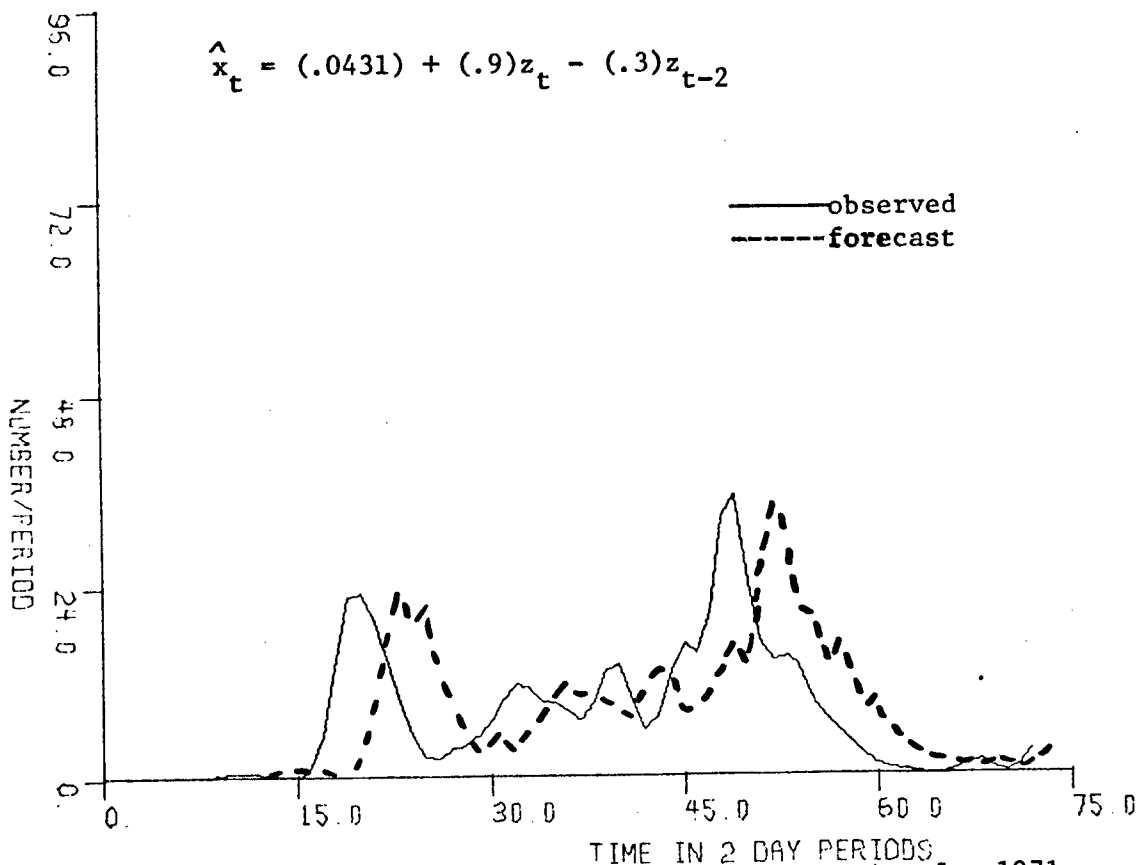


Fig. 6 Observed vs. 4-day ahead forecast series for 1971 smoothed data.

4. TIME SERIES MODELS FOR RAW DATA. A data-smoothing technique such as that applied by Hacker et.al. is a reasonable approach to use if one can demonstrate that the sample population density data is more erratic than that expected for the true density behavior and if one can identify the sources of noise in the data. However, to the knowledge of the present authors, this has not been done. Hence, the nagging possibility remains that smoothing techniques may remove basic, essential components of the data. In this section we avoid the problems inherent in the use of smoothed values to predict smoothed values by formulating statistical time series models for the raw data itself. The following graphs show the results of applications of the procedure discussed in Section 2 to the three sets of raw data.

In Figure 7, the raw data collected during May through October, 1969 is shown, along with the one day ahead forecast generated from the moving average model of order 3:

$$\hat{x}_{t+1} = -(0.08) - (.83)x_t - (.71)x_{t-1} - (.34)x_{t-2} \quad (4.0)$$

Again, the agreement is quite good except for the characteristic time lag.

Figure 8 is a visual display of the stationarity test of step (i). If a series is stationary, then its sample autocorrelation function,  $r_{xx}(k)$ , should dampen out to zero fairly rapidly where

$$r_{xx}(k) = \frac{\sum_{t=1}^{n-k} (x_t - \bar{x})(x_{t+k} - \bar{x})}{\sum_{t=1}^n (x_t - \bar{x})(x_{t+k} - \bar{x})}, \quad \text{for } k = 0, 1, \dots, n-1 \quad (4.1)$$

As can be seen,  $r_{xx}(k)$  does not dampen out quickly for the original series (solid line) but upon application of a second difference filter,  $y_t = x_t - 2x_{t-1} + x_{t-2}$ ,  $r_{yy}(k)$  for the filtered series does dampen out quickly (dotted line).

Figures 9 and 10 show the 1-day ahead forecasts for the raw data collected during May through October, 1970 and 1971, respectively. For the 1970 data, a first difference filter was required for stationarity and the forecasts were generated from the second order moving average process.

$$\hat{x}_t = -(0.014) - (.20)z_{t-1} - (.30)z_{t-2} \quad (4.2)$$

The 1971 raw data required a second order difference filter for stationarity and the forecasts were generated from the third order moving average process.

$$\hat{x}_t = (.056) - (.99)z_{t-1} - (.09)z_{t-2} + (.18)z_{t-3} \quad (4.3)$$

The graphs for the sample autocorrelation functions are not included here since they are qualitatively similar to Figure 8.



ORIGINAL TIME SERIES

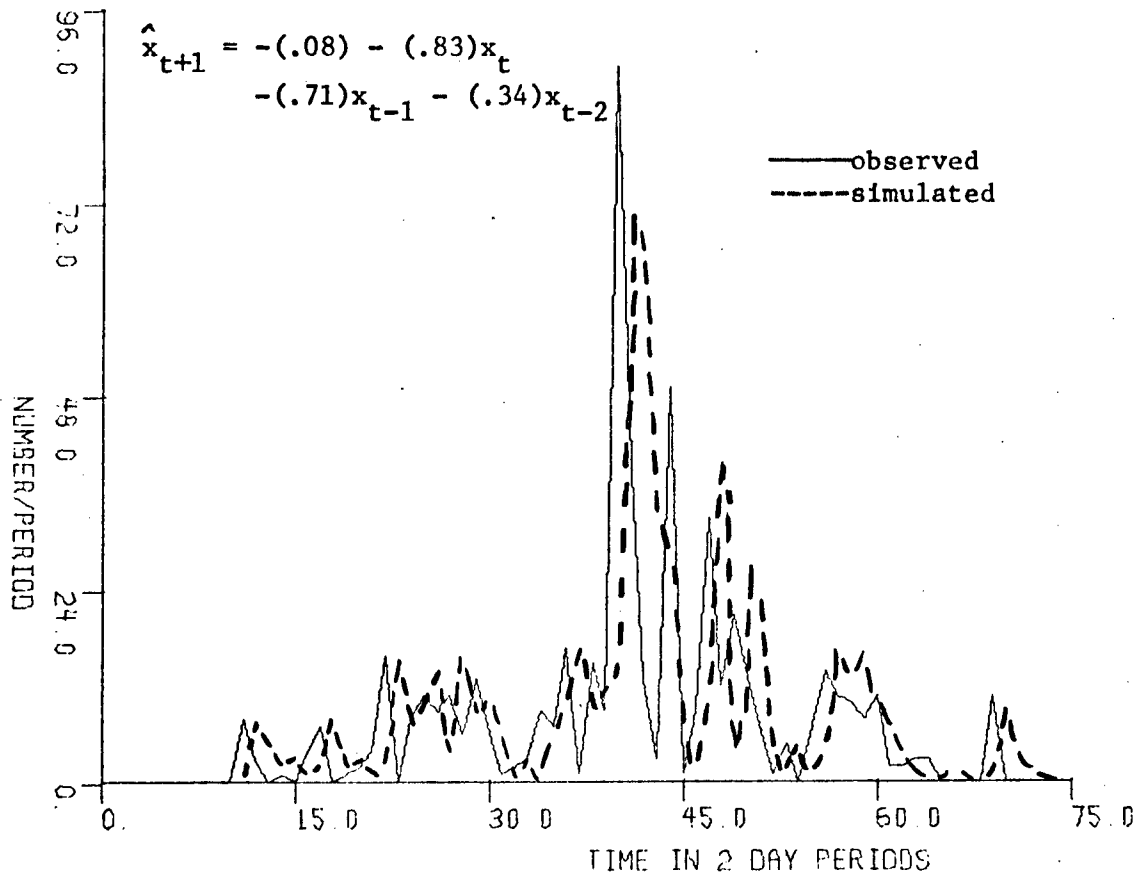


Fig. 7. Observed series vs. 1-day ahead forecast for 1969 raw density data.

SAMPLE AUTOCORRELATION FUNCTION

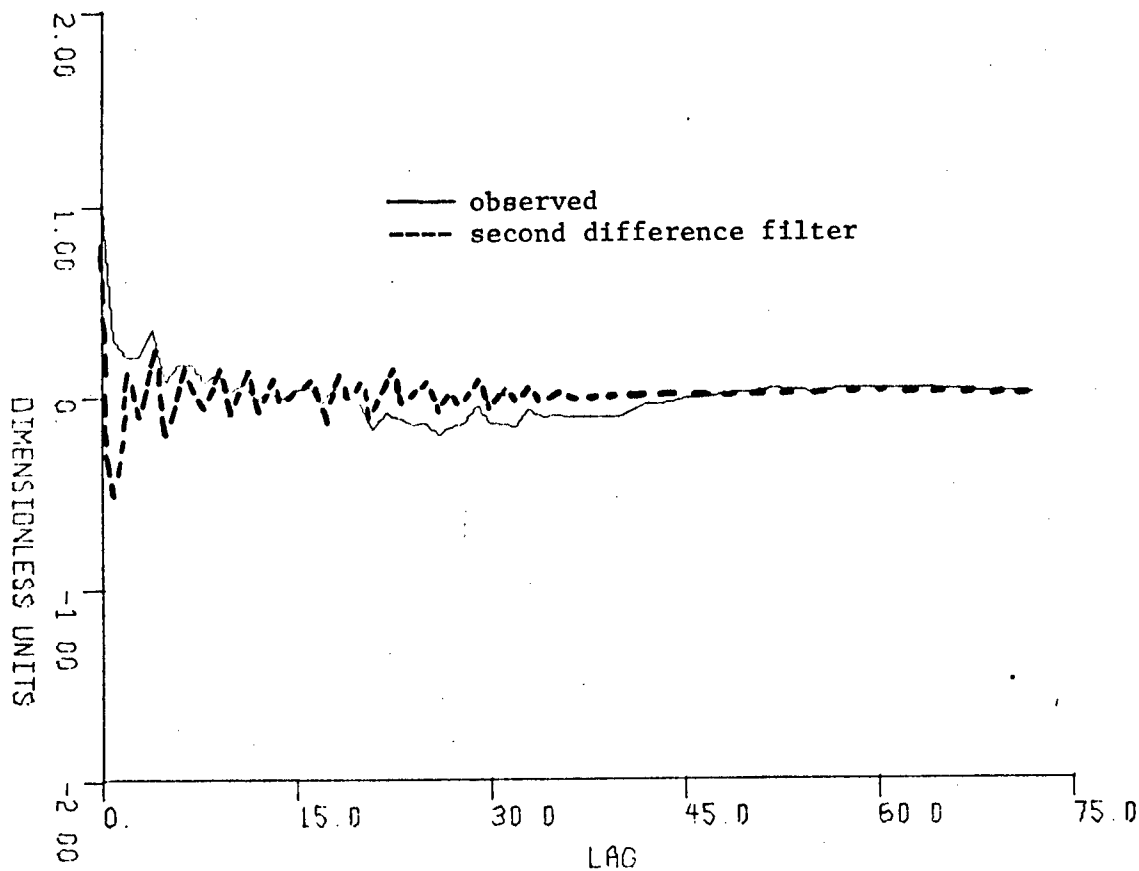


Fig. 8. Sample autocorrelation for observed vs. second difference filtered series for 1969 raw data.

ORIGINAL TIME SERIES

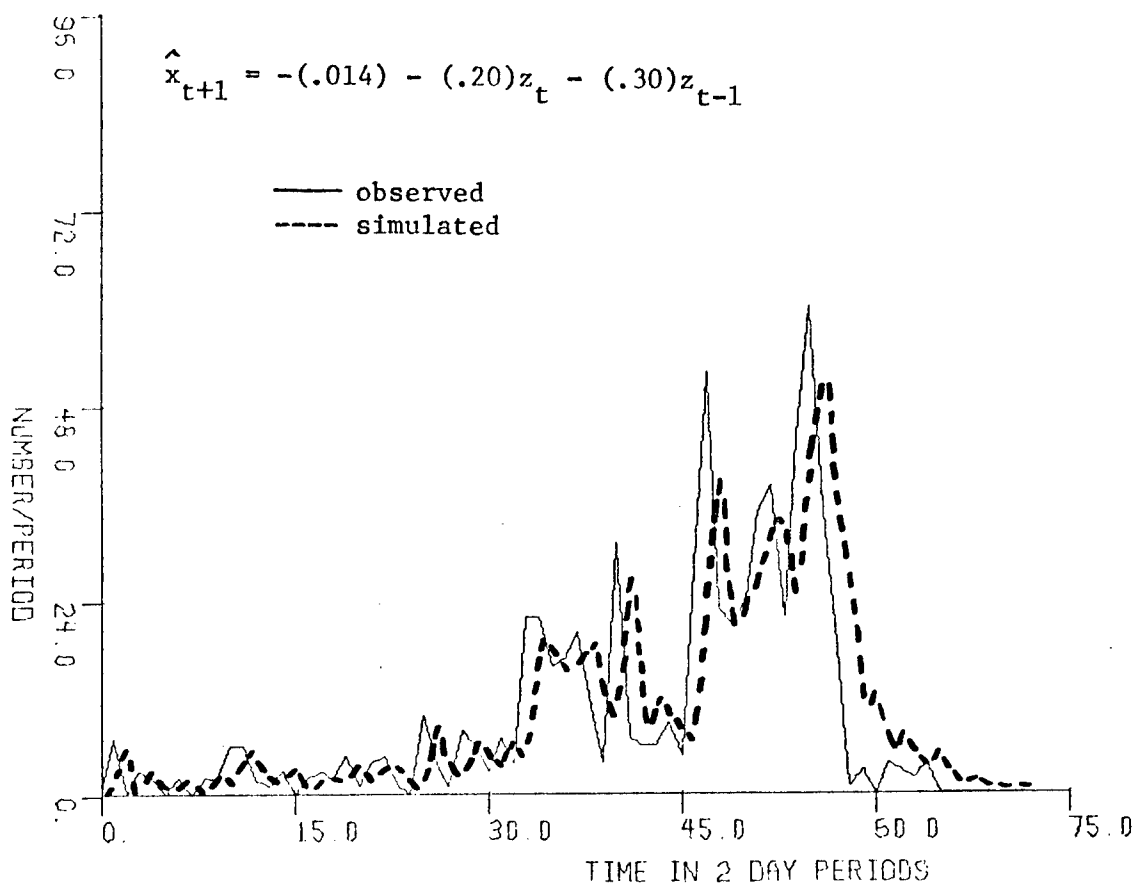


Fig. 9. Observed series vs. 1-day ahead forecast for 1970 raw density data.

ORIGINAL TIME SERIES

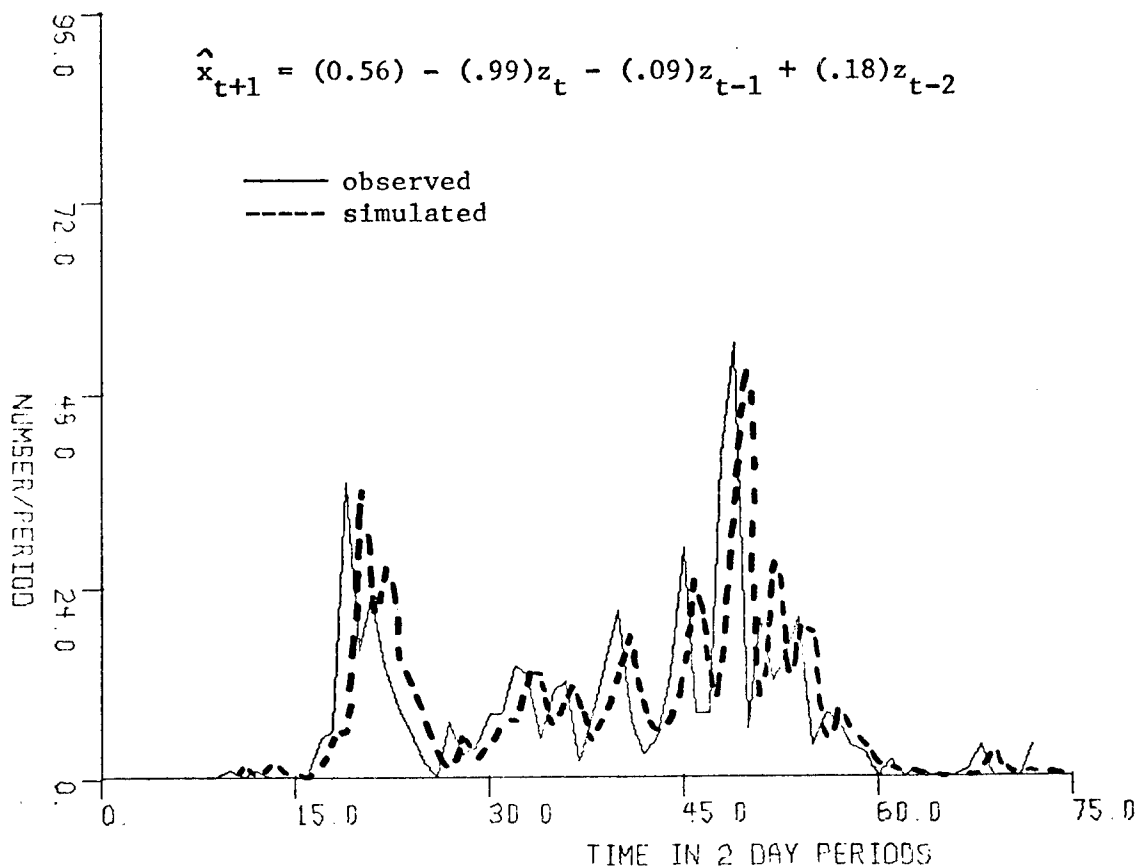


Fig. 10. Observed series vs. 1-day ahead forecast for 1971 raw density data. 540

5. CONCLUSION. It has been shown in previous sections that the techniques discussed here can provide adequate forecasting models for non-stationary time series, even if those series have suspected, but unaccounted-for noise components. This seems to be an important improvement over the smoothing approach used by Hacker et.al. If the source of the noise is not identified, then one can not be sure that smoothing the data will lead to a set of data that is more representative of the true state of nature. The technique developed in the present investigation avoids this problem by formulating time series models using the raw data itself. (It should be pointed out that the complete procedure discussed in the previous sections is contained within a software computer package developed by the authors.)

Further research along the lines of the present investigation is now being contemplated. Hacker et.al. discuss a method for using their model equations to develop simulation studies useful in evaluating various control strategies for mosquito populations. Their method consists of adding the (previously suppressed) error term,  $\epsilon_t$ , assumed to be normally distributed. They then can sample independent random normal variates with the same variance as that estimated from the data, and use these values to drive the process. It turns out, however, that using a random walk of this type occasionally yields pseudo-observations outside the range of those observed in the Malvern study. To remedy this, they employ a mathematical condition that reflects the process away from the boundaries of negative values and overly-large values. The present authors are considering application of this simulation approach to the models developed here, which we believe are more representative models of actual behavior of mosquito population densities.

In addition to the simulation studies, the present authors are initiating a spectral analysis approach to the study of this problem. Such an approach will give a better understanding of the intricate details and inter-relationships between the essential variables involved in the study of the behavior of mosquito populations.

#### ACKNOWLEDGEMENT

The authors wish to thank Professor James Thompson, Department of Mathematical Sciences, Rice University for supplying us the data and for his fruitful discussion with us concerning this problem.

#### REFERENCES

- [1] C.S. Hacker, et.al. "A Forecasting Model for Mosquito Population Data", J. Med. Ent., 10, (1973), 544-551.
- [2] C.P. Tsokos, "Forecasting Models from Non-stationary Time Series; Short-term Predictability of Stocks", in Mathematical Methods in Investment and Finance, (Szego and Shell, eds.) North Holland, 1972.

## CURVE FITTING OF DISCRETE POINTS BY LEGENDRE POLYNOMIALS

Oskar M. Essenwanger  
Physical Sciences Directorate  
US Army Missile Command  
Redstone Arsenal, Alabama 35809

**ABSTRACT.** It is well known that the Legendre polynomials render the least square fit, while Tchebycheff polynomials provide the minimum of the maximum deviation from the observed points. Therefore, it should be assumed that the selection of the desired type would depend only on the primary goal of the analysis.

Legendre polynomials are in widespread use in mathematics, but their application to statistical problems is rarely found. This can not always be attributed to the differences in goals between statistical and mathematical analysis. One of the reasons may be the difficulty of adjustment of Legendre polynomials to discrete point curve fitting as necessary in statistical analysis. While the Tchebycheff series is orthogonal for discrete points, the orthogonality of the Legendre series is based on the continuous type and does not hold up for a small number of discrete points.

The author has attempted to display first the fitting of discrete points by Legendre polynomials and compare the results with the Tchebycheff series. Furthermore, examples are given for the calculation of the coefficients of the Legendre series from discrete points, and their relationship with the left variance. Finally, the most advantageous utilization of Legendre polynomials in statistical analysis is a fitting to  $N > 50$  where the Tchebycheff series becomes difficult to handle.

**1. INTRODUCTION.** Although certain types of polynomials such as the Legendre polynomials are in widespread use for curve fitting in mathematics, their application in statistical analysis can rarely be found. It is a well known fact that individual polynomial types serve a special purpose and have particular properties. Among orthogonal polynomials the Legendre polynomials render the least square fit while the Tchebycheff polynomials provide a solution where the maximum deviation is a minimum.

It may be speculation that this latter property is a preferred goal in statistical analysis, and therefore the Tchebycheff series is mostly utilized. This fact is contradicted, however, by various articles whose authors have employed empirical polynomials. Thus one would think least square solutions should be found among the desired analysis goals, and one could discover Legendre polynomial fits in statistical analysis.

As it will become clear from the subsequent discussion, one possible reason for the absence of Legendre polynomial fits may be the difficulty of adjusting Legendre polynomials to discrete point fitting. Many data in statistical analysis are given or prepared in the form of discrete points rather than the continuous type of solution which are usually illustrated in mathematical texts, although a limited number of discontinuities in the observations (step functions) have been accepted in numerical analysis.

The fitting of Legendre polynomials to discrete points has, therefore, been studied in details in the subsequent sections. As we shall learn the major problem is not the preparation of Legendre polynomials for discrete point fitting. The difficulty lies in the determination of the proper coefficients for the series from discrete points. Although the Legendre series is orthogonal in a continuum, the series loses its orthogonality for a small number of discrete points.

As will be outlined coefficients from integrals can be calculated by numerical methods, but disadvantages still remain with respect to the left variance. The Tchebycheff and the Legendre series are fitted to wind profile data and the results are comparable. It will be learned, however, that the Legendre series would be most advantageously used for the number of points greater than 30, even better for more than 50 points where no table values for the Tchebycheff series are readily available, and the orthogonality of the Legendre series is restored. It should be added that orthogonalized sets of discrete Legendre polynomials for few points assume the same numerical values as found for the Tchebycheff series.

2. THE LEGENDRE SERIES. As can readily be found in various texts (e.g. Boas, 1966; Abramowitz and Stegun, 1964; Essenwanger, 1975a, etc.) the Legendre polynomials comprise an orthogonal system over the interval  $-1 \leq x \leq 1$ . For details of their analytical expressions the reader is referred to the literature. Let us denote here the Legendre polynomial by  $P_n(x)$ , where  $n$  represents the order.

The Legendre polynomials are orthogonal, i.e.

$$\int_{-1}^{+1} P_h P_k dx = \begin{cases} 2/(2n+1) & \text{for } h = k = n \\ 0 & \text{for } h \neq k. \end{cases} \quad (1)$$

Any function  $Y(z)$  would be represented by Legendre polynomials with the transformation  $y(x) = Y(z)$ . Then

$$y(x) = \sum_{n=0}^{\infty} a_n P_n(x). \quad (2)$$

The coefficients must be determined from

$$a_n = \left[ (2n+1)/2 \right] \int_{-1}^{+1} y(x) P_n(x) dx, \quad (3)$$

and here begins the difficulty in practical work with discrete points. If  $Y(z)$  is a function which can be expressed in analytical terms, and the integral can be solved explicitly, the representation of any function by Legendre polynomials is trivial. Such examples can be found in almost any text on mathematics or numerical analysis where polynomials are covered. In the atmospheric sciences or other branches with statistical analysis we are mostly interested, however, in expressing a discrete function  $Y(z)$  by polynomials. While the coefficients for the Tchebycheff series are simple to calculate even in this case, the usual procedure of replacing the integral by the summation sign is insufficient for a small number of points, i.e. we cannot merely state

$$a_n = \left[ (2n+1)/2 \right] \sum_{x=-1}^1 y(x) P_n(x) \Delta x. \quad (4)$$

This replacement would be a permissible approximation for a large number of points, say probably for about 30 or more and the number of terms  $n \ll 30$ . For a small number of points, i.e. seven, this formula generally does not provide the coefficients  $a_n$  accurate enough to be of value.

We may evaluate the success of engaging eqn. (1) by calculating two polynomial characteristics, the variance  $\text{Var}_P$  and an integral, which we may call  $S_L$ . The two parameters have analytical solutions depending on  $n$  and are defined by

$$\text{Var}_P = \int_{-1}^{+1} P_n^2(x) dx = 2/(2n+1), \quad (5)$$

$$\text{and } S_L = \int_0^{+1} P_n(x) dx = \sum_{\nu=0}^{n/2} (-1)^\nu \frac{1 \cdot 3 \cdot 5 \dots (2n-2\nu-1)}{2^\nu \nu! (n-2\nu)!} \frac{1}{(n-2\nu+1)}$$

$$= 0 \text{ for even } n \neq 0. \quad (6)$$

Against these expected values the empirical counterparts can be obtained.

$$\text{Var}'_P = \sum_{i=1}^s P_n^2(x_i) \Delta x \rightarrow \frac{2}{(2n+1)} \quad (7)$$

$$s \rightarrow \infty$$

The summation

$$S'_L = \sum_{x_i=0}^{x_i=1} P_n(x_i) \Delta x \quad (8)$$

is somewhat more difficult to calculate due to considerations in the marginal class intervals. If the two border points  $x_i = 0$  and  $x_i = 1$  are utilized, the  $P_n(x_i=0)$  and  $P_n(x_i=1)$  must be multiplied by

$$\Delta x/2. \text{ Otherwise, } \sum_{x_i=0}^{x_i=1} \Delta x = 1 \text{ is not fulfilled.}$$

Transformation from the  $z$  to the  $x$  system is based on the equalization of the ranges and references, i.e.  $x_r = z_r$ . Consequently

$$x/x_r = (z-z_0)/z_r \quad (9)$$

(the reference equivalent to  $z_0$  is  $x_0 = 0$ ).

Since most of the observed discrete variables can be arranged in steps of class intervals, two versions of the transformation must be accommodated. Let us assume that 7 points  $Y(z_i)$  are given. We number the variate  $z$  from  $z_1 = 1$  through  $z_7 = 7$  (with unity steps). If other scales are given, they can be reduced to this basic form (see later Table 1). The transformation in this case can be written (with  $x_r = 2$  and  $z_r = z_7 - z_1 = 6$ )

$$\frac{x}{2} = \frac{1}{6} (z-4) \quad (10a)$$

or  $3x + 4 = z. \quad (10b)$

We shall call this version one.

If we consider  $z_1 = 1$  with a lower class boundary of  $z_1 = 0.5$  and the upper boundary of  $z_u$  as  $z_{r_u} = 7.5$ , the  $z_r = z_{7_u} - z_1 = 7$ , and  $\frac{x}{2} = \frac{1}{7} (z-4)$  (11a)

or  $3.5x + 4 = z. \quad (11b)$

This may be called version two. The resulting Legendre polynomials for these two interpretations are given in Table 1. The respective  $Var'_p$  and  $S'_L$  parameters are listed in Table 2 for four different number of points.

It is self-evident that the expected  $Var'_p$  and  $S'_L$  are best approximated for the largest subdivision, namely 31 points. The second version renders a slightly better approximation than the first version. The deviation increases with ascending polynomial order. In other words, at least about 30 points are needed to calculate the coefficients accurately enough by mere summation.

It will be further seen that the discrete Legendre polynomials for a small number of points are not fully orthogonal (see Table 3).



Table 1. Legendre Polynomial Terms for 7 Discrete Points.

z	P <sub>0</sub>	Version 1, Δx = 1/6					Version 2, Δx = 1/7 (x at midpoint of class)				
		x = P <sub>1</sub>	P <sub>2</sub>	P <sub>3</sub>	P <sub>4</sub>	P <sub>5</sub>	x = P <sub>1</sub>	P <sub>2</sub>	P <sub>3</sub>	P <sub>4</sub>	P <sub>5</sub>
1	1	-1.0	1.0	-1.0	1.0	-1.0	-0.857	0.602	-0.289	-0.019	0.260
2	1	-0.667	0.167	0.259	-0.427	0.306	-0.571	-0.010	0.391	-0.383	0.081
3	1	-0.333	-0.333	0.407	0.012	-0.333	-0.286	-0.378	0.370	0.098	-0.347
4	1	0	-0.500	0	0.375	0	0	-0.500	0	0.375	0
5	1	0.333	-0.333	-0.407	0.012	0.333	0.286	-0.378	-0.370	0.098	0.347
6	1	0.667	0.167	-0.259	-0.427	-0.306	0.571	-0.010	-0.391	-0.383	-0.081
7	1	1.0	1.0	1.0	1.0	1.0	0.857	0.602	0.289	-0.019	-0.260

Table 2. Summation of Eqn. 7 and 8. (See Text.)

	V' <sub>P<sub>n</sub></sub>					S' <sub>L</sub>				
	P <sub>1</sub>	P <sub>2</sub>	P <sub>3</sub>	P <sub>4</sub>	P <sub>5</sub>	P <sub>1</sub>	P <sub>2</sub>	P <sub>3</sub>	P <sub>4</sub>	P <sub>5</sub>
True value	2/3	2/5	2/7	2/9	2/11	1/2	0	-1/8	0	1/16
for integral	0.667	0.400	0.226	0.222	0.182	0.500	0	-0.125	0	0.0625
Version 2										
7 points	0.653	0.360	0.213	0.130	0.111	0.490	-0.010	-0.135	-0.033	0.0016
11 points	0.661	0.384	0.254	0.175	0.124	0.496	-0.004	-0.129	-0.013	0.0371
21 points	0.665	0.395	0.277	0.208	0.161	0.499	-0.001	-0.126	-0.007	0.0554
31 points	0.666	0.398	0.282	0.215	0.172	0.499	-0.0005	-0.126	-0.001	0.0593
Version 1										
7 points	0.704	0.509	0.489	0.502	0.470	0.500	0.028	-0.056	0.091	0.176
11 points	0.680	0.440	0.363	0.343	0.340	0.500	0.10	-0.100	0.033	0.1052
21 points	0.670	0.410	0.306	0.254	0.229	0.500	0.003	-0.119	0.008	0.0734
31 points	0.668	0.404	0.295	0.237	0.203	0.500	0.001	-0.112	0.004	0.0673

3. DETERMINATION OF THE CONSTANTS. As can be readily seen from Table 3, the discrete series of Legendre polynomials for a small number of points is not fully orthogonal. In an orthogonal system only the diagonal of the matrix would remain non-zero. Thus the calculation of coefficients is problematic by replacing an orthogonal system and the integral by summation. The coefficients of a non-orthogonal system can be properly calculated as outlined for linear systems (see Essenwanger, 1975a). This is equivalent of converting the "covariance matrix" (left) into the "coefficient matrix" (right):

$$\begin{bmatrix} \Sigma P_0^2 & \Sigma P_1 P_0 & \Sigma P_2 P_0 \dots \Sigma P_n P_0 & \Sigma P_0 y \\ \Sigma P_0 P_1 & \Sigma P_1^2 & \Sigma P_2 P_1 \dots \Sigma P_n P_1 & \Sigma P_1 y \\ \vdots & \vdots & \vdots & \vdots \\ \Sigma P_0 P_n & \Sigma P_1 P_n & \Sigma P_2 P_n \dots \Sigma P_n^2 & \Sigma P_n y \end{bmatrix} \rightarrow \begin{bmatrix} 1.0 & 0 & 0 \dots 0 & A_0 \\ 0 & 1.0 & 0 \dots 0 & A_1 \\ \vdots & \vdots & \vdots & \vdots \\ 0 & 0 & 0 & 1.0, A_n \end{bmatrix}$$

This conversion has been treated in many texts or by the author (1975b, section 3) and is equivalent with the diagonalization of a matrix.

This technique does not provide "Legendre coefficients" unless the matrix contains a sufficient number of terms (i.e. orders of  $P_i$ ). E.g. the following coefficients are obtained for an approximation of  $y(x)$  being a third plus fourth order Tchebycheff polynomial of 7 points (see Table 8). The last row in each version of Table 4 is identical with the Legendre coefficients.

Table 3. Covariance matrix for 7-point discrete Legendre polynomials.

	Version 1						Version 2					
	$P_0$	$P_1$	$P_2$	$P_3$	$P_4$	$P_5$	$P_0$	$P_1$	$P_2$	$P_3$	$P_4$	$P_5$
$P_0$	7.0	0	1.17	0	1.55	0	7.0	0	-0.07	0	-0.23	0
$P_1$	0	3.11	0	1.38	0	1.81	0	2.29	0	-0.16	0	-0.34
$P_2$	0.17	0	2.53	0	1.66	0	-0.07	0	1.26	0	-0.28	0
$P_3$	0	1.38	0	2.47	0	1.89	0	0.16	0	0.75	0	-0.34
$P_4$	1.55	0	1.66	0	2.51	0	-0.23	0	-0.28	0	0.45	0
$P_5$	0	1.81	0	1.89	0	2.41	0	0.34	0	-0.34	0	0.39

Table 4. Coefficients for 3, 4 and 5 term of the discrete Legendre polynomials.

$a_0$	Version 1				Version 2				
	$a_1$	$a_2$	$a_3$	$a_4$	$a_0$	$a_1$	$a_2$	$a_3$	$a_4$
0	0	0	-	-	0	0	0	-	-
0	-0.8	0	1.8	-	0	0.20	0	2.86	0
-1.3	-0.8	-6.5	1.8	10.8	0.71	0.20	4.42	2.86	20.01

We learn from this table that the "Legendre coefficients" (last row) are not the most advantageous coefficients for an incomplete system, but the solutions converge with the inclusion of a sufficient number of (or all possible) terms. Some readers may prefer this method of calculating coefficients since it is mathematically exact and it certainly proves advantageous once the number of terms in the series has been decided upon. As in any non-orthogonal system, the addition of terms requires a recalculation of coefficients, however.

It is also possible to utilize numerical solution for calculation of integrals, such as Gregory's or Simpson's rule (see Essenwanger, 1975a, or Abramowitz and Stegun, 1964). The author (1975a) has developed an iterative process, which in combination with Gregory's or Simpson's technique, works reasonably well. This combination is necessary since Gregory's or Simpson's approximation becomes less efficient for the higher order terms while given correct entries for the lower order terms the iterative steps lead to good approximations (see Tables 5 and 6).

As evident from Table 4, the coefficients from the covariance matrix are not identical "Legendre coefficients" as they would be obtained from analytical solutions of the coefficient integrals (eqn. 3). The two sets converge only after a sufficient number of terms is carried.

In the utilization of numerical methods for calculation of integrals, however, the "Legendre coefficients" are obtained directly, if possible, without further modification (see Table 5). The reader may ask whether it would be desirable to calculate Legendre polynomial coefficients under these circumstances because they do not provide the best fit for an insufficient number of terms.

It may be replied that generally curve fitting is of little value unless at least 80 to 90% of the variance has been explained. In these cases the coefficients from the solution via the covariance matrix and numerical methods from integrals merge (see also later the example, section 6). The question should be rephrased: Do the Legendre polynomials fulfill any need since the orthogonal system of Tchebycheff polynomials is available? The answer will be given after some further discussion.

Table 5. Coefficients of the Legendre Polynomial Series for a fourth order Tchebycheff term with 7 points.

	Version 1						Version 2		
	True	G	S	Iteration		$a_0$ & $a_2$ Known	True	w/o It	It
				Only	with $a_0$				
$a_0$	-1.30	-1.30	-1.30	-0.50	-1.30	-1.30	0.71	0	0
$a_1$	0	0	0	0	0	0	0	0	0
$a_2$	-6.50	-6.50	-6.53	-7.96	-6.90	-6.50	4.42	0	0
$a_3$	0	0	0	0	0	0	0	0	0
$a_4$	10.80	23.5	23.1	10.70	10.68	10.80	20.01	9.90	16.86
$a_5$	0	0	0	0	0	0	0	0	0

G = Gregory, S = Simpson, It = Iteration

Table 6. Recomputed fourth order Tchebycheff polynomial term for 7 points for the coefficients as given by Table 5.

i	y(x)	Version 1					Version 2		
		G	S	Only	$a_0$	$a_0 + a_2$	w/o It	It	
1	3	15.2	15.2	2.2	2.5	3.0	-0.2	-0.3	
2	-7	-12.2	-12.3	-6.4	-7.0	-7.0	-3.8	-6.6	
3	1	1.2	1.2	2.3	1.1	1.0	1.0	1.7	
7	6	10.6	10.6	7.5	6.2	6.0	3.7	6.4	
5	1	1.2	1.2	2.3	1.1	1.0	1.0	1.7	
6	-7	-12.2	-12.3	-6.4	-7.0	-7.0	-3.8	-6.6	
7	3	15.2	15.2	2.2	2.5	3.0	-0.2	-0.3	

4. ORTHOGONALIZATION OF DISCRETE LEGENDRE POLYNOMIALS. The reader may ask whether the discrete Legendre polynomials could be orthogonalized. Without doubt, orthogonalization is technically feasible, and the author has produced an orthogonalized set of polynomials for the 7-point Legendre polynomials which were given in Table 1. This orthogonalized set is exhibited in Table 7. It must be reported first that version 1 and version 2 merged to only one set after this orthogonalization procedure.

A closer perusal of the orthogonalized set reveals that the columns of Table 7 are now identical with the Tchebycheff 7-point polynomials except for rounding and a multiplication factor. This has been found for other number of points, too. Identity with the Tchebycheff system implies, however, that this orthogonalized set has also assumed the properties of the Tchebycheff polynomials. Consequently there would be no reason why the Tchebycheff polynomials could not be employed a priori, since the original purpose of utilizing the Legendre series is defeated with the change of properties. Consequently for a small number of points  $N$  the discrete Legendre series would not be very advantageous while its application for a larger  $N$  (e.g.  $N > 30$ ) should prove useful.

Table 7. Orthogonalized set of discrete Legendre polynomials of Table.

$P_1$	$P_2$	$P_3$	$P_4$	$P_5$
-0.5669	0.5455	-0.4083	0.2417	-0.1092
-0.3780	0	0.4083	-0.5641	0.4363
-0.1890	-0.3273	0.4083	0.0806	-0.5457
0	-0.4365	0	0.5641	0
0.1890	-0.3273	-0.4083	0.0806	0.5457
0.3780	0	-0.4083	-0.5641	-0.4363
0.5669	0.5455	0.4083	0.2417	0.1092

This statement is even more valid for  $N > 50$  because most table values of Tchebycheff polynomials discontinue after  $N = 50$ . Since for larger  $N$  the integral in eqn. (3) can be replaced by the summation sign with sufficient accuracy, and the Legendre system becomes orthogonal again, the difficulties encountered for few points disappear.

5. THE PERCENTAGE REDUCTION AND LEFT VARIANCE. It was previously pointed out that the goal in curve fitting can also be classified as an attempt to describe the variance of the function  $y$  by a mathematical expression. If the match is perfect, the variances  $\sigma_y^2$  of the given data and  $\sigma_y^2$  of the analytical counterpart, are identical. We can, therefore, mathematically formulate a criterion of the success in curve fitting by defining a left variance

$$\epsilon_L^2 = \Sigma(y_i - y_{ai})^2 / N. \quad (12)$$

The explained variance is then

$$\epsilon_E^2 = \sigma_y^2 - \epsilon_L^2. \quad (13)$$

The measure

$$Z_R^2 = \epsilon_E^2 / \sigma_y^2 = 1 - \epsilon_L^2 / \sigma_y^2 \quad (14a)$$

can be called reduction, and

$$Z_{PR}^2 = Z_R^2 \cdot 100\% \quad (14b)$$

is then the percentage reduction.

As illustrated in detail (Essenwanger, 1975a) the left variance can be written as

$$\epsilon_L^2 = \sigma_y^2 + (a_0 - \bar{y})^2 + M_z \quad (15)$$

where  $\sigma_y^2$  denotes the variance of  $y$ , and  $\bar{y}$  is the mean,  $a_0$  the polynomial coefficient of order zero. The  $M_z$  denotes the summation of the elements in

$$M_z = \begin{pmatrix} -2a_1 \Sigma y P_1 & -2a_2 \Sigma y P_2 & \dots & -2a_n \Sigma y P_n \\ 2a_0 a_1 \Sigma P_1 & 2a_0 a_2 \Sigma P_2 & \dots & 2a_0 a_n \Sigma P_n \\ \hline a_1^2 \Sigma P_1^2 & a_1 a_2 \Sigma P_1 P_2 & \dots & a_1 a_n \Sigma P_1 P_n \\ a_1 a_2 \Sigma P_1 P_2 & a_2^2 \Sigma P_2^2 & \dots & a_2 a_n \Sigma P_2 P_n \\ \vdots & \vdots & \ddots & \vdots \\ a_1 a_n \Sigma P_1 P_n & a_2 a_n \Sigma P_2 P_n & \dots & a_n^2 \Sigma P_n^2 \end{pmatrix}$$

We define

$$M_{z_0} = (a_1^2 \Sigma P_1^2 + a_2^2 \Sigma P_2^2 + \dots + a_n^2 \Sigma P_n^2). \quad (16)$$

Then in an orthogonal system  $M_z = -M_{z_0}$  and  $M_z \equiv \epsilon_E^2$  (see Essenwanger, 1975a). Furthermore,  $a_0 \equiv \bar{y}$  and

$$\epsilon_L^2 = \sigma_y^2 - M_{z_0} = \sigma_y^2 - \epsilon_E^2. \quad (15a)$$

In a non-orthogonal system eqn. (15) cannot be reduced to simple terms. Because  $a_0$  is not necessarily  $\bar{y}$  in a non-orthogonal system, we could define

$$S_y^2 = \sigma_y^2 + (a_0 - \bar{y})^2 \quad (17)$$

and

$$Z_R^2 = 1 - \epsilon_L^2 / S_y^2. \quad (14c)$$

Let us assume that the given data are the two terms

$$y = \phi_3 + \phi_4$$

for the Tchebycheff polynomials for seven points. This example has been selected because the coefficients of the Legendre polynomials series can be calculated by integration. The following table results.

Table 8. Given  $y$  and coefficients.

i	$\phi_3$	$\phi_4$	y	First Version	Second Version
				$a_{i-1}$	$a_{i-1}$
1	-1	3	2	-1.3	0.709
2	1	-7	-6	-0.8	-0.204
3	1	1	2	-6.5	4.424
4	0	6	6	+1.8	2.858
5	-1	1	0	10.8	20.008
6	-1	-7	-8	0	0
7	1	3	4		

The  $y_a = a_0 + a_1 P_1 + a_2 P_2 + a_3 P_3 + a_4 P_4$ , with the coefficients of Table 8, and  $y_a$  is identical with the data  $y_1$ . Thus we have a perfect match. Now  $\bar{y} = 0$  and  $\sigma_y^2 = 160/7 = 22.857$  where  $\sigma_{\phi_3}^2 = 6/7$  and  $\sigma_{\phi_4}^2 = 22.0$ .

Hence  $z_3^2 = 3.8\%$  and  $z_4^2 = 96.2\%$  for the Tchebycheff series.



The matrix  $M_z$  (version 1) becomes for the six coefficients  $a_0$  through  $a_5$ :

$M_z =$	0	0	-1.71	-44.00	0	Line Sum
	0	2.82	0	-6.20	0	-45.71
	0.28	0	-0.28	0.0	0	-3.38
	0	15.26	0	-16.67	0	0
	-0.28	0.0	1.14	0	0	-1.41
	0.0	-16.67	0	41.76	0	0.86
	0.0	0.0	0	0	0	25.00
						<u>0.0</u>
					-24.55	

The summation of all elements of  $M_z = -24.55$ . Consequently,

$$\epsilon_L^2 = 22.86 + 1.69 - 24.55 = 0$$

is confirmed.

The left variance of the individual term sequence is

$$\epsilon_{0L}^2 = \Sigma(y - a_0)^2 / N = 24.55 = 22.86 + 1.69$$

$$\epsilon_{1L}^2 = \Sigma(y - a_0 - a_1 P_1)^2 / N = 24.83 = 24.55 + 0.28$$

$$\epsilon_{2L}^2 = \Sigma(y - a_0 - a_1 P_1 - a_2 P_2)^2 = 24.83 + 18.08 = 42.91, \text{ etc.}$$

$$\epsilon_{3L}^2 = 41.76$$

$$\epsilon_{4L}^2 = 0.$$

The corresponding numbers for version two are 23.36, 23.37, 26.83, 25.96, 0. It leads to the percentage reduction as displayed in Table 9.

Table 9. Percentage Reduction.

Part a. Cumulative Value.

		TERM					
		0	1	2	3	4	5
Version 1	with $\sigma_y^2$	-7.4	-8.6	-87.7	-82.7	100%	100%
	with $S_y^2$	0.0	-1.2	-74.8	-70.1	100%	100%
Version 2	with $\sigma_y^2$	-2.2	-2.3	-17.4	-13.6	100%	100%
	with $S_y^2$	0.0	-0.1	-14.9	-11.1	100%	100%

Part b. Individual Terms.

		0	1	2	3	4	5
Version 1	with $\sigma_y^2$	-7.4	-1.2	-79.1	5.0	182.7	0
	with $S_y^2$	0.0	-1.2	-73.6	4.7	170.1	0
Version 2	with $\sigma_y^2$	-2.2	-0.1	-15.1	3.8	113.6	0
	with $S_y^2$	0.0	-0.1	-14.8	3.8	111.1	0

The positive reduction begins in both versions with the third order term. Although the actual percentage contributions of the third and fourth order terms are not completely identical with the numbers from the Tchebycheff system, the important features run parallel; namely a small contribution from a third order term and a considerable dominance of the fourth order term. It may be further concluded that a representation including only the three coefficients  $a_0$  through  $a_2$  is inadequate. In fact, the assumption of zero for these three coefficients above would leave a smaller left variance than the actual value (see matrix coefficients Table 4). For more details see Essenwanger (1975a).

6. AN EXAMPLE FOR WIND PROFILE REPRESENTATION. Two wind profiles at 2 km altitude level intervals were arbitrarily selected, January 1, 1957 and 1958 at Montgomery. The following Table 10 exhibits the empirical data and the approximation by polynomials up to the fifth order. Since the correct coefficients for Legendre polynomials cannot be determined a priori, the effect of the approximation cannot be directly shown. It may be inferred, however, that the reconstructed curve from the Legendre polynomials should have a smaller sum of the squared deviations from the analytical data than for the Tchebycheff approximation. As can be readily checked, however, both sums are about the same. This may be seen as a confirmation of an earlier conclusion that for less than about twenty points the advantage of the Legendre series over the Tchebycheff series may not show up in practical work.

As an added feature, the percentage reduction is displayed. No problems are apparent for the Tchebycheff series, whereas the third order term in version 1 is negative which demonstrates a slight increase of the left variance on both dates. The percentage reductions for the individual terms have been calculated by eqn. 14a. While  $S_y^2$  is the basis for the reduction in version 1, the  $a_0 \equiv \bar{y}$  version 2 and  $S_y^2 \equiv \sigma_y^2$ .

Although differences in the percentage reduction between the three systems exist, the numbers are equivalent and imply the same integrated effect. The second order term dominates considerably. Besides this second order term, a fourth order term contributes to the 1957 date and a fifth order term for 1 January 1958. The other components may be considered to have minor influence.

7. CONCLUSION. As has been pointed out in the beginning, the Legendre series is different from the Tchebycheff series in its theoretical approach to curve fitting. Some difficulty arises when the Legendre series is applied to a discrete function  $y(x)$ . For a small number of points (e.g.  $N < 30$ ) the discrete Legendre polynomials are not fully orthogonal and the coefficients cannot readily be calculated from the regular coefficient formula in replacing the integral by a summation sign. Some outlines for an approximation are given, and more details can be found by Essenwanger (1975a).

It was pointed out that in the sequence of this non-orthogonal system for a small number of points the coefficients are not independent, and the contribution to the left variance by the individual term may become negative. Thus the contribution by the individual order cannot be readily judged by customary methods for an orthogonal system.

**Table 10.** Comparison of Representing a Wind Profile by Tchebycheff and Legendre Polynomials.

**a. Recomputed Wind Profile (Montgomery).**

1 Jan 57						1 Jan 58					
$z(x)$ m/sec	Tche	Legendre		Matrix		$y(x)$ m/sec	Tche	Legendre		Matrix	
		V1	V2	V1	V2			V1	V2	V1	V2
6	5.7	3.1	6.1	5.8	5.8	5	3.7	0.7	6.1	3.7	3.7
12	13.2	12.5	12.7	13.2	13.2	14	18.3	18.9	17.8	18.3	18.3
23	20.8	20.3	20.4	20.8	20.8	23	21.0	21.9	20.2	21.0	21.0
28	30.1	29.5	30.1	30.1	30.1	31	24.7	24.6	24.3	24.7	24.7
41	39.5	38.9	39.8	39.5	39.5	27	32.7	31.8	32.7	32.7	32.7
44	45.7	45.5	46.2	45.7	45.7	40	42.5	41.3	42.7	42.5	42.5
47	45.7	45.8	46.2	45.7	45.7	51	48.4	47.6	48.9	48.4	48.4
38	37.8	38.2	38.4	37.8	37.8	46	45.5	45.4	46.2	45.5	45.5
23	23.9	24.1	24.4	23.9	23.9	34	32.2	32.8	33.4	32.3	32.3
11	10.5	10.4	10.4	10.5	10.5	12	14.8	14.8	15.2	14.8	14.8
11	11.1	11.0	8.5	11.1	11.1	10	9.1	6.7	6.1	9.1	9.1

**b. Coefficients.**

$a_0$	25.82	27.21	25.82	27.52	25.90	26.64	28.51	26.64	28.82	26.57
$a_1$	0.43	+2.13	2.33	1.44	2.90	0.95	4.35	5.20	4.52	6.14
$a_2$	-1.49	-29.56	-30.10	-29.01	-38.81	-1.45	-25.22	-29.14	-25.25	-28.78
$a_3$	-0.04	4.21	-2.04	-4.18	-0.28	-0.18	-12.69	-9.81	-12.75	-6.27
$a_4$	0.83	9.40	14.23	9.91	14.50	0.23	0.37	4.01	2.79	4.08
$a_5$	0.54	6.00	7.78	5.41	8.71	1.10	11.35	15.85	10.94	17.61

**c. Percentage Reduction.\***

	§	§	§	§	§	§	§	§	§	§
1st	0.9	0.9	0.9	±0.8	0.9	4.2	4.1	4.2	4.1	4.0
2nd	86.9	82.7	86.9	84.0	86.6	76.2	76.2	76.1	76.5	76.2
3rd	0.3	-0.8	0.2	-1.1	0.1	5.7	-0.1	5.8	0.1	4.9
4th	9.0	13.0	8.9	11.9	9.2	0.7	0.2	0.6	0.8	0.7
5th	2.1	3.0	1.9	3.5	2.3	8.1	13.7	7.3	13.3	9.0
TOTAL	99.2	98.8	98.8	99.1	99.1	94.9	94.1	94.0	94.8	94.8

V1 - Version 1

V2 - Version 2

\* Percentage reduction for  $S_y^2$  (see eqn. 17).

As the Legendre polynomials for discrete points become simpler to handle with increasing number of points, they should prove to be a useful replacement for the Tchebycheff polynomials in solutions of problems where the practical application of the Tchebycheff polynomial method apparently shows a weakness such as for  $N > 50$ .

It is difficult to evaluate a priori, whether the calculation of coefficients via the covariance matrix is more cost effective than the approximations of the "true" Legendre coefficients. It is self-evident that the calculation of the covariance matrix adds to the computer costs in the matrix solution while the major part of the costs for the "Legendre coefficient" remains with the approximation and iteration.

#### 5. REFERENCES CITED:

Abramowitz, M. and Stegun, I. A., (editors), 1964. Handbook of Mathematical Functions. National Bureau of Standards, 1046 pp.

Boas, M. L., 1966. Mathematical methods in the physical sciences. Wiley & Sons, New York, 778 pp.

Essenwanger, O. M., 1975a. Applied statistics in atmospheric science, Vol. I, frequencies and curve fitting. In print by Elsevier, Amsterdam-New York.

Essenwanger, O. M., 1975b. Elements of statistical analysis in climatology. In publication by Elsevier, Amsterdam-New York.

Acknowledgement: I wish to express my gratitude to Dr. Dorathy A. Stewart for her critical review of the manuscript. Mrs. Brooks deserves the credit for painstakingly typing the text and tables.

METHODOLOGY AND INSTRUMENTATION DIVISION  
MATERIEL TEST DIRECTORATE  
U.S. ARMY YUMA PROVING GROUND, YUMA, ARIZONA 85364

FIRE CONTROL SENSITIVITY ANALYSIS  
USING A  
PROGRAMMABLE CALCULATOR

THOMAS O. MCINTIRE  
JANUARY 1975

CONTENTS

- |                                      |                           |
|--------------------------------------|---------------------------|
| 1. INTRODUCTION                      | 6. GENERAL FLOW CHART     |
| 2. CALCULATOR PROGRAM DESCRIPTION    | 7. "LOOP" FLOW CHART      |
| 3. FIRE CONTROL SENSITIVITY ANALYSIS | 8. DATA SCALING ROUTINE   |
| 4. BALLISTIC FIRE CONTROL EQUATIONS  | 9. SAMPLE PROGRAM LISTING |
| 5. LINE OF SIGHT (LOS) CONVERSION    | 10. SAMPLE PLOTS          |

---

1. INTRODUCTION

Fire Control Sensitivity Analysis (the effect of a change in conditions on the aim of a weapon system) is normally accomplished on high-speed computers because of the extensive calculation required. These computers are, however, expensive to program and operate when only a short or 1-time program is needed. Since the purpose of the analysis herein was for pre-test information there was no inherent need for fast computations. Since a programmable calculator was available the analysis was programmed on it.

It was soon apparent that the physical limitations of the memory and computation speed demanded special techniques. The first of these techniques was to minimize the number of calculations which needed full precision. The second technique was to put the answers after each run onto a cassette tape to free memory for the next run. The third was to code the output answers, which has a large dynamic range, into integers, thereby reducing the amount of cassette tape required. The fourth technique was to write an iterative routine which automatically varied the routines and controlled the output onto tape. This technique allowed the unattended operation of the calculator.

The unattended operation of the calculator is the most significant feature of the program. It allowed in this case 150 hours of operation time during nights and weekends. The sole operator requirement was to load and unload cassette tape at the end and beginning of the work-day. The detail of the specific program shown herein is to illustrate the very extensive calculations which can be performed even by small and slow calculators. It must be noted that even more extensive programs can be and have been implemented by daisy-chaining the output of one program into the input of another program.

## 2. CALCULATOR PROGRAM DESCRIPTION

Equipment: Hewlett-Packard 9830 with 3808 word memory

Program: Non-critical variables written in single (6-digit) or integer (+215) precision notation. Memory capacity available only for a single run. Output data scaled as integers and stored along with the scaling factor on cassette tape. A typical program is included as Section 10.

Operating Conditions: Computation time of single derivative was 30 seconds. Number of derivatives calculated was 11 instead of 21 because the rate of change of derivatives did not warrant more. Computation was therefore approximately 5 minutes per run. (900 valid runs were calculated for the analysis.) The program was typically set up with indexing for 162 runs which required approximately 15 hours of computation. The program and data tape was normally loaded at the end of the day and retrieved in the morning. The only printed output generated was a single line listing the critical information contained in each of the 162 files.

Output Processing: Output data from the program was stored on six cassette tapes. A plotting routine read nine files and decoded them into memory. The plotter was then used to generate plots as shown in Section 9.

### Comments:

1. The program generates LOS angles which are independent of ballistics and are better outputted separately.
2. The operating and storage requirements are based on 21-point runs instead of the 11 actually used.
3. Changing the program to accommodate Comments 1 and 2 would allow more runs to be in memory. This would reduce output requirements considerably, tape requirements by 3 and files by 9.
4. Comment 3 was not implemented because the savings did not warrant programming multiple plotting routines for different output formats.

### 3. FIRE CONTROL SENSITIVITY ANALYSIS

1. Weapon ballistic data is generally given with respect to the weapon line of sight (LOS) coordinate system. Aircraft position is given in terms of pitch, roll and heading.
2. From the aircraft viewpoint, the conversion into the LOS coordinates is straight-forward because the LOS angles relative to the airframe are known. From the sensitivity analysis viewpoint, however, the LOS angle are unknown and must be calculated.
3. A conversion routine from the aircraft data into the LOS system was developed for this analysis. The conversion matrix and its development is shown in Section 5 of this paper.
4. The second major part of the program is the iterative solution of the fire control equation in the LOS system. The fire control equations and the iteration technique is shown in Section 4.
5. The sensitivity (partial derivative) of the fire control solution was then determined by changing a single parameter and determining the change in the solution. It should be noted that if all 12 parameters were used in this analysis technique, the output would approach infinity (12 sets of 3 values each equal 531,441).
6. Because of this, only pitch, roll and heading are changed for the analysis of each value. The other parameters were chosen either a maximum (i.e. range) or were determined to have small linearized responses (i.e. effects would be additive).

The parameters used were heading (0,45,135\*), pitch (-20,0,10), roll (0,30,60), range 40mm (1500M), 30mm (3000M), 7.62mm (2000M), airspeed (100MPS), wind speed cross- and head- (0) Yaw angle\*\* (0), altitude (0) rate of climb (0), air density (1.0), muzzle velocity standard.

---

\*75 for 40mm (weapon could not reach the target at right angle).

\*\*Yaw angle is the angle between the aircraft heading and airspeed.



#### 4. BALLISTIC FIRE CONTROL EQUATIONS

$$B_L = -[(U_{A_L} + G_L G_P + A_5 \text{ TOF}) / U_B] + A_6 (T/X_S) W_L \\ + A_8 [B_S (U_{A_M} - W_M) - B_M (U_{A_S} - W_S)] / V$$

$$B_M = -[(U_{A_M} + G_M G_P) / U_B] + A_Z (T/X_S) / W_M \\ + A_8 [B_L (U_{A_S} - W_B) - B_S (U_{A_L} - W_L)] / V$$

$$\text{TOF}_{\text{vac}} = X_S / (U_{B_S} + U_{A_S} + (.5 G_S X_S / U_{B_S} + U_{A_S}))$$

$$\Delta T = \text{TOF}_{\text{vac}} (\rho / \rho_S) V (A_1 X_S + A_2 X_S^2)$$

$$\text{TOF} = \text{TOF}_{\text{vac}} + \Delta T$$

These equations cannot be explicitly solved because the right-hand expression contains terms dependent upon the value calculated. This makes the solution iterative, with the previously calculated values being used in the equation. Because of the nature of the equation, the convergence to a specific value is extremely rapid. It can be shown that the error due to truncating the iteration is less than the change due to the last iteration.

Since there are two equations to be solved, the updating of values was also done between the solution of the two equations.

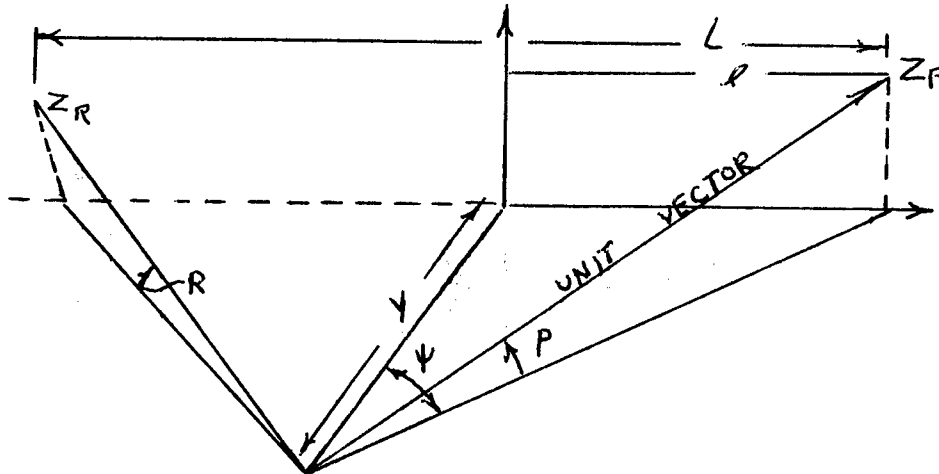
Derivatives of the Sensitivity Program were calculated by changing one of the parameters and calculating the change in the ballistic equations. The convergence check in the program was set to allow errors of less than 0.01 milliradian.

#### Definitions

<u>B</u>	Unit vector along barrel (or launcher)
<u>G</u>	Gravity vector
<u>L</u>	Unit vector in the direction of axis about which elevation of <u>S</u> is measured
<u>M</u>	Unit vector <u>L</u> X <u>S</u> (up is positive)
<u>S</u>	Unit vector in direction of launcher to target
<u>S</u> , <u>M</u> , <u>L</u>	Line of sight coordinate system
TOF	Time of flight
TOF vac	Time of flight in vacuum
<u>U<sub>A</sub></u>	Aircraft velocity
<u>U<sub>B</sub></u>	Projectile velocity relative to barrel
<u>V</u>	Projectile velocity relative to air
<u>W</u>	Windspeed
<u>X</u>	Position vector of target
$\rho / \rho_S$	Actual/standard air density

## 5. DERIVATION OF LINE OF SIGHT (LOS) CONVERSION ROUTINE

1. Project Aircraft Attitude Unit Vector onto a vertical plane normal to 0 heading vector. R = roll, P = pitch,  $\psi$  = heading



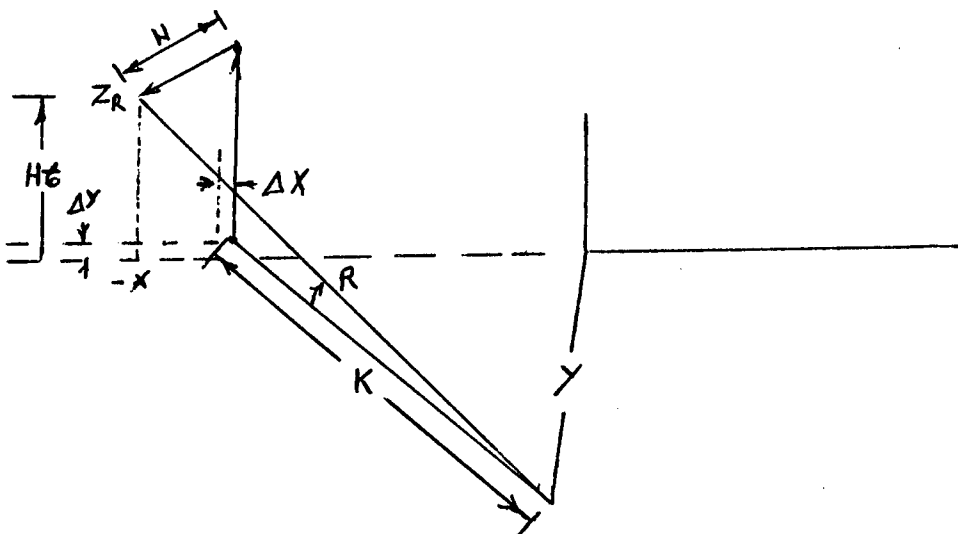
Upon examination we can obtain:

$$Y = \text{Cos } P \text{ Cos } \psi$$

$$L = \text{Cos } P \text{ Sin } \psi$$

$$Z_P = \text{Sin } P$$

2. Examining roll projection and using the fact that  $Z_R$  is in the plane; we obtain:



$$Ht = K \tan R \cos P = Z_R$$

$$N = K \tan R \sin P$$

$$\Delta Y = N \cos \psi$$

$$\Delta X = N \sin \psi$$

Because  $Z_R$  is in plane we further obtain:

$$Y = K \sin \psi - \Delta Y \text{ or } K \sin \psi - K \tan R \sin P \cos \psi$$

$$-X = K \cos \psi + \Delta X \text{ or } K \cos \psi + K \tan R \sin P \sin \psi$$

$$K = \frac{\cos \psi \cos P}{\sin \psi - \tan R \sin P \cos \psi}$$

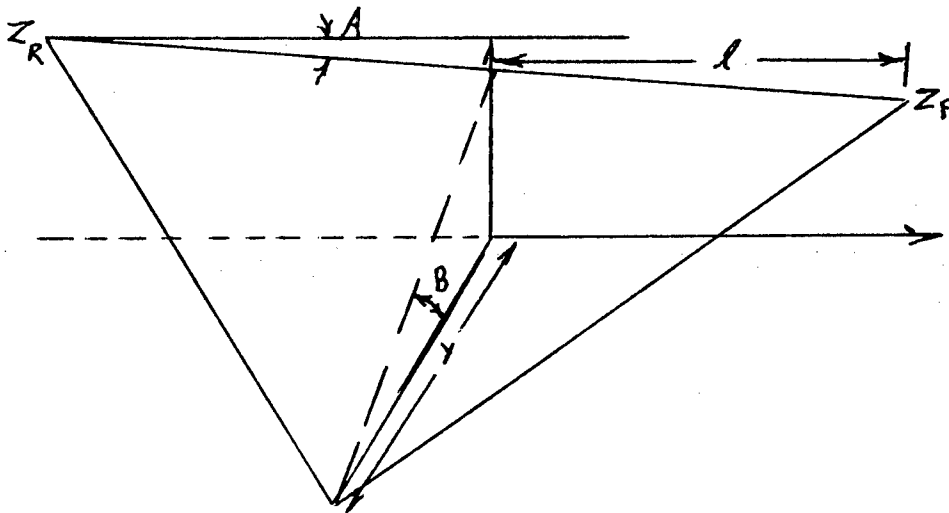
$$1/K = \frac{\tan \psi - \tan R \sin P}{\cos P} = \textcircled{H3}^*$$

\*Circled items are computer program names

$$L = \sin \psi \cos P = K (\cos \psi + \tan R \sin P \sin \psi); (1/K)(L) = \textcircled{H3}^* \sin \psi \cos P +$$

$$(\cos \psi + \tan R \sin P \sin \psi) = \textcircled{H4}$$

3. The Aircraft Unit Vector and points  $Z_R$  and  $Z_p$  describe a plane which can be described by the angles  $A$  and  $B$  as shown.



We have by inspection:

$$\tan A = (Z_p - Z_R)/L$$

$$\tan B = (Z_p - \tan A l)/y$$

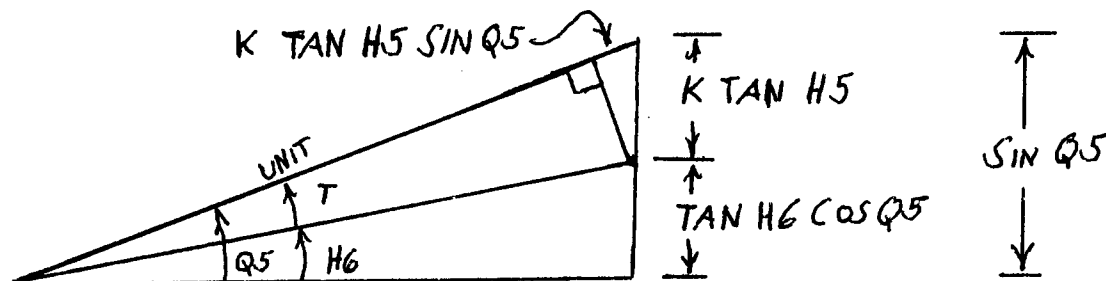
$$= (\sin P - \tan A \sin \psi \cos P) / (\cos P \cos \psi)$$

Dividing top and bottom of Tan A by K we have:

$$A = \text{ATAN} '(H3 \sin P - \text{Tan } R \cos P)/H4 = \textcircled{H5}$$

$$B = \textcircled{H6} = A \text{ Tan}'(\sin P - \text{Tan } H5 \sin \psi \cos P)/(\cos P \cos \psi)$$

4. Conversion from the vertical plane angles to the Line of Sight. Q5 angle from horizontal of the LOS to target.



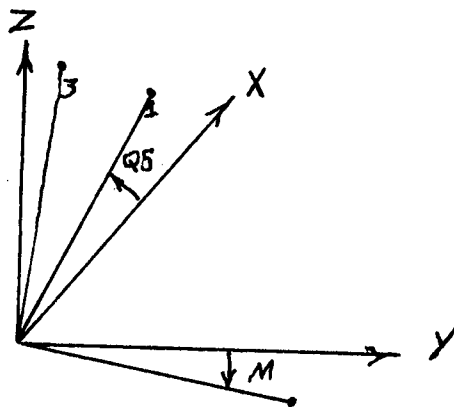
$$H5 = \sin Q5 - \text{Tan } H6 \cos Q5$$

$$\text{Tan } T = \frac{\cos Q5 (\text{Tan } H5) K}{1 - \sin^2 Q5 + \sin H6 \cos Q5 \sin Q5}$$

$$\text{Tan } T = \frac{K (\text{Tan } H5)}{\cos Q5 + \text{Tan } H6 \sin Q5}$$

$$\text{Apparent angles } M = A \text{ tan} \frac{\text{Tan } H5}{\cos Q5 + \text{Tan } H6 \sin Q5}$$

5.



Rotating by angle M around LOS 1 the positions of the unit vector 1, 2 and 3 become:

1.  $X = \cos Q5, y = 0, Z = \sin Q5$

2.  $X = \sin M \sin Q5, y = \cos M, Z = -\sin M \cos Q5$

3.  $X = -\sin Q5 \cos M, y = \sin M, Z = \cos M \cos Q5$

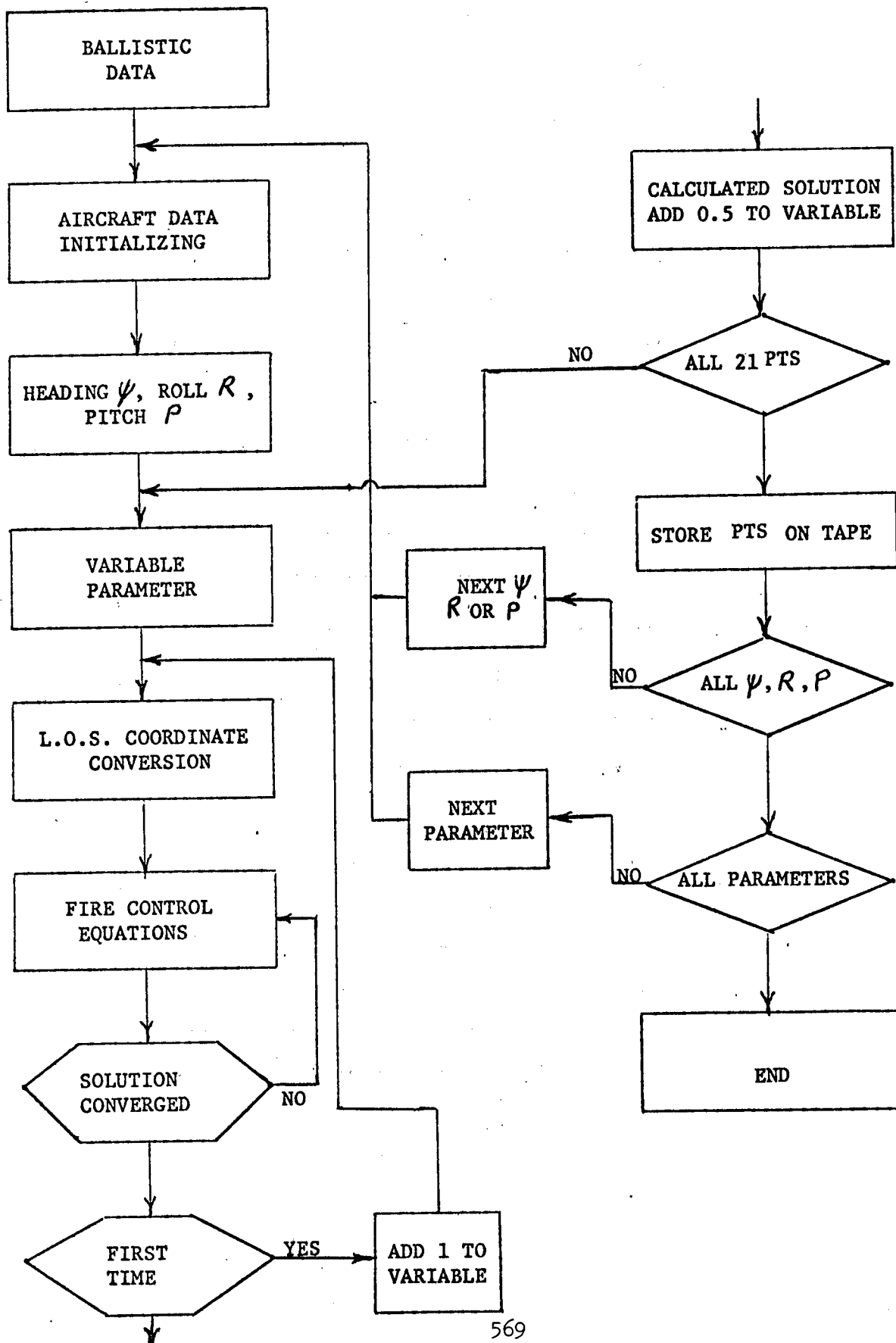
Which expressed in MATRIX FORM is:

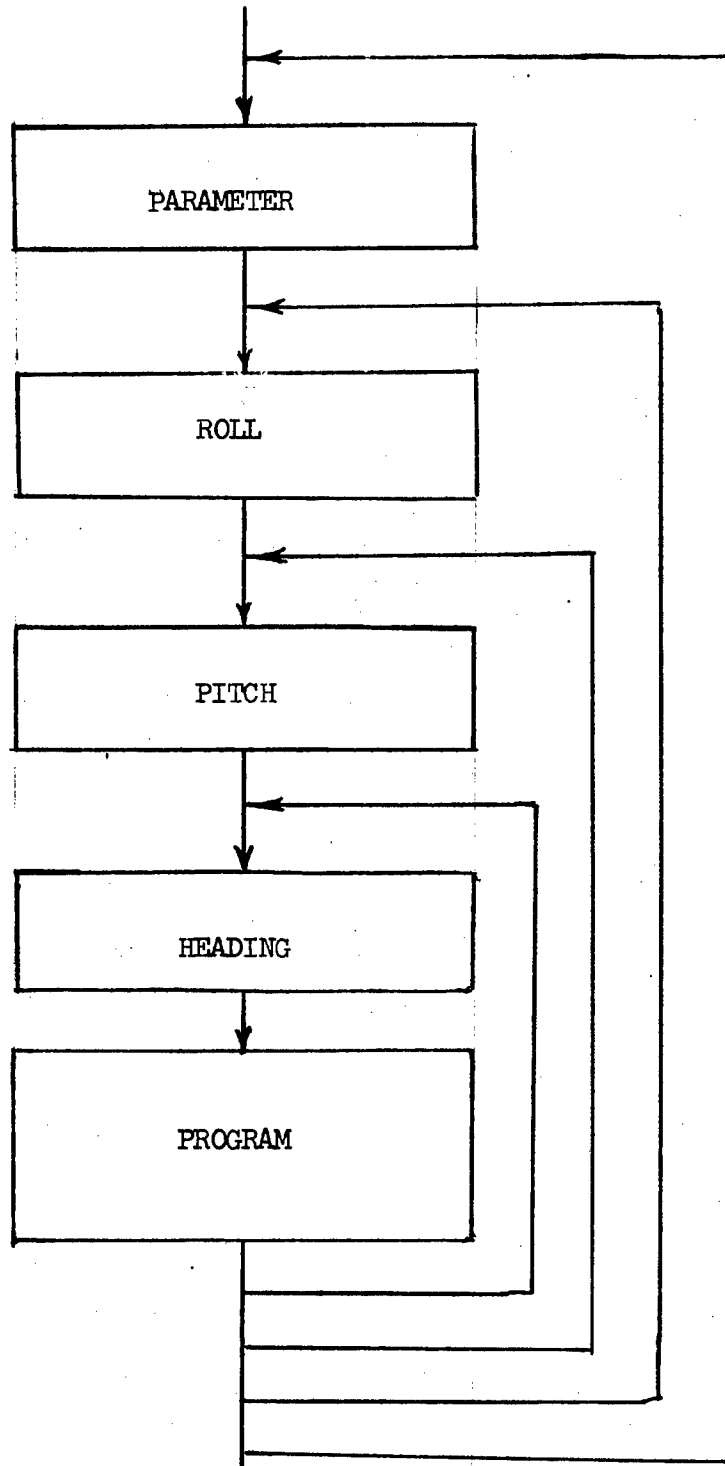
$\cos Q5$	$0$	$\sin Q5$
-----------	-----	-----------

$\sin M \sin Q5$	$\cos M$	$-\sin M \cos Q5$
------------------	----------	-------------------

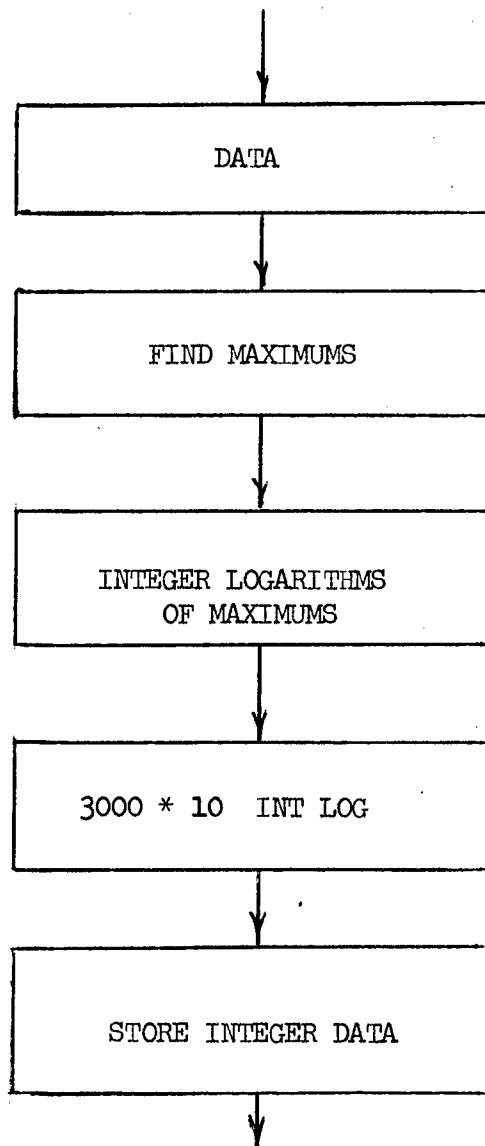
$-\sin Q5 \cos M$	$\sin M$	$\cos M \cos Q5$
-------------------	----------	------------------

6. GENERAL FLOW CHART





7. "LOOP" FLOW CHART



8. DATA SCALING ROUTINE



```

40 DATA FSC(3,3),DF(3,3),FSC(3,3),KL(3,3),Zs(3,3),MSL(3,3),SE(3,3),HPS(3,3)
50 DATA UC(3,1),UC(3,1),UC(3,1),MC(3,1),XC(3,1),YC(3,1),TC(3,1),G(3,1),VL(3,1),IL(3,1)
60 DATA
70 READ X1,X2,06,07,08,09,00,P1,P2
80 DATA 1000,0,50,0,0,0,0,400,1
90 PRINT "RANGE="X1,"ALTITUDE="X2
100 PRINT "HORIZ AIRSPD="06,"CLIMB="07,"YAW="08
110 PRINT "WINDSPEED="09,"DIRECTION="00
120 DATA BD(1,1),BD(2,1),BD(3,1),L2,M2
130 DATA 1,0,0,0,0
140 READ A1,A2,A3,A4,A5,A6,A7,A8
150 DATA 1.11E-04,3.51E-08,-1.89E-04,5.71E-08,0.56,-1.52,1.3,0
160 RESTORE
170 PRINT "MUZZLE VEL="P1,"AIR DENSITY="P2
180 PRINT:
190 FOR B=1 TO 5
200 PRINT:
210 PRINT:
220 FOR C=1 TO 3
230 PRINT:
240 PRINT:
250 FOR D=1 TO 3
260 DATA 02=0
270 GOTO 310
280 02=30
290 GOTO 310
300 03=20
310 DATA 04 OF 320,340,360
320 01=-20
330 GOTO 370
340 01=0
350 GOTO 370
360 01=10
370 DATA 05 OF 380,400,420
380 03=0
390 GOTO 430
400 02=45
410 GOTO 430
420 03=135
430 FOR 04=0 TO 20 STEP 2
440 DATA 06 OF 450,470,490,510,530,550,570
450 05=9+0-0.5
460 GOTO 510
470 05=5+0-0.5
480 GOTO 510
490 07=1*0-0.5
500 GOTO 570
510 P2=0,01*0+0.8-R,095
520 GOTO 570
530 P1=839.724*(0.95+0.005*0-0.005)
540 GOTO 570
550 06=90
560 09=0.5*0-0.5

```

```

570 R=0
580 Q4=(X2/X1)/(SQRT(1-(X2/X1)^2))
590 Q5=-ATN(Q4)
600 D1,1]=COSQ1
610 D1,2]=0
620 D1,3]=+SINQ1
630 D2,1]=SINQ1*SINQ2
640 D2,2]=COSQ2
650 D2,3]=-SINQ2*COSQ1
660 D3,1]=-COSQ2*SINQ1
670 D3,2]=SINQ2
680 D3,3]=COSQ1*COSQ2
690 I1=SINQ3
700 I2=COSQ3
710 F1,1]=I2
720 F1,2]=I1
730 F1,3]=0
740 F2,1]=-I1
750 F2,2]=I2
760 F2,3]=0
770 F3,1]=0
780 F3,2]=0
790 F3,3]=1
800 H1=TAN(Q2)*COS(Q1)
810 H3=(TAN(Q3)-TAN(Q2)*SIN(Q1))/COS(Q1)
820 H2=H3*SIN(Q1)
830 H4=H3*SIN(Q3)+COS(Q1)+COS(Q3)+TAN(Q2)*SIN(Q1)*SIN(Q3)
840 H5=ATN((H2-H1)/H4)
850 H6=ATN((SIN(Q1)-TAN(H5)*SIN(Q3)*COS(Q1))/(COS(Q3)*COS(Q1)))
860 M=ATN(-TAN(H5)/(COS(Q5)+SIN(Q5)*TAN(H6)))
870 K1,1]=COSQ5
880 K1,2]=0
890 K1,3]=SINQ5
900 K2,1]=+SIN(Q5)*SINM
910 K2,2]=COSQ5
920 K2,3]=+COS(Q5)*SIN(M)
930 K3,1]=-SIN(Q5)*COSM
940 K3,2]=+SINM
950 K3,3]=COS(M)+COS(Q5)
960 MAT G=INV(D)
970 MAT Z=INV(F)
980 MAT J=K*Z
990 MAT E=J*G
1000 L4=EI1,3]/(SQRT(1-EI1,3]^2))
1010 L5=ATN(L4)
1020 IF ABS(EI2,2])>.1 THEN 1080
1030 L6=-EI2,1]/EI2,2]
1040 L7=ATN(L6)
1050 IF EI2,2])>0 THEN 1130
1060 L7=L7+180
1070 GOTO 1130
1080 L6=-EI2,2]/EI2,1]
1090 L7=ATN(L6)
1100 L7=90-L7
1110 IF EI2,1])<0 THEN 1130
1120 L7=L7-180

```

```

1130 GI 1 J=0
1140 GI 2 J=0
1150 GI 3 J=-9.8
1160 UI 3 J=07
1170 UI 2 J=06+SIN(Q8+Q3)
1180 UI 1 J=06+COS(Q8+Q3)
1190 HI 1 J=09*COSQ0
1200 HI 2 J=09*SINQ0
1210 HI 3 J=0
1220 MAT X=K*G
1230 MAT Y=K*U
1240 MAT T=K*W
1250 MAT C=(P1)*B
1260 MAT I=Y+T
1270 MAT V=I+C
1280 V=SOR(VI 1 J+2+VI 2 J+2+VI 3 J+2)
1290 T1=X1/(CI 1 J+YI 1 J+(0.5*XI 1 J*X1/(CI 1 J+YI 1 J)))
1300 T2=T1*P2*(A1*X1+A2*X1*X1)
1310 T3=T1+T2
1320 P3=T3/(2+(P2*V*T3*(A3+A4*X1)))
1330 L1=-((I[2 J]+X[2 J]*P3+A5*T3)/P1+A6*T2*T[2 J]/X1
1340 L1=L1+A8*(BI 1 J*(I[3 J]-T[3 J])-BI 3 J*(I[1 J]-T[1 J]))/V
1345 IF (BI 3 J+2+L1+2)>1 THEN 1461
1350 BI 1 J=SOR(1-BI 3 J*BI 3 J-L1*L1)
1360 M1=-((I[3 J]+X[3 J]*P3)/P1)+(A7*T2*T[3 J]/X1)
1370 M1=M1+A8*(L1*(I[1 J]-T[1 J])-BI 1 J*(I[2 J]-T[2 J]))/V
1375 IF (M1+2+L1+2)>1 THEN 1461
1380 BI 1 J=SOR(1-M1*M1-L1*L1)
1390 M3=ABS(M1-BI 3 J)
1400 L=ABS(L1-BI 2 J)
1410 DISP M3,L
1420 IF M3>0.000001 THEN 1440
1430 IF L<0.000001 THEN 1470
1440 HI 3 J=M1
1450 BI 2 J=L1
1460 GOTO 1250
1461 X9=27*(D-1)+9*(C-1)+3*(B-1)+A
1462 PRINT X9"NO SOLUTION POSSIBLE UNDER THIS CONDITION"
1463 GOTO 2350
1470 IF R=1 THEN 1680
1480 L8=L5
1490 L9=L7
1500 L2=L1
1505 M4=BI 1 J
1510 M3=M1
1520 GOTO D OF 1530,1550,1570,1590,1610,1630,1630
1530 Q3=Q3+1
1540 GOTO 1640
1550 Q6=Q6+1
1560 GOTO 1640
1570 Q7=Q7+1
1580 GOTO 1640
1590 P2=P2+0.01
1600 GOTO 1640
1610 P1=P1*(1.01)
1620 GOTO 1640
1630 Q9=Q9+1

```

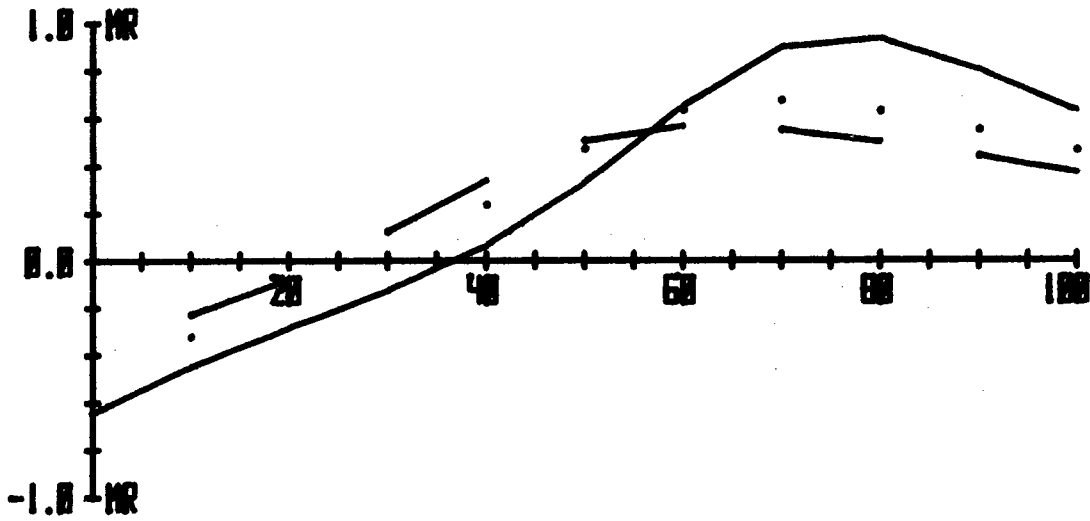
```

1640 R=1
1650 R=1
1660 GOTO 580
1670 L2=L1
1680 GOTO D OF 1690,1710,1730,1750,1770,1790,1790
1690 NC0+1,1]=Q3-0.5
1700 GOTO 1800
1710 NC0+1,1]=Q6-0.5
1720 GOTO 1800
1730 NC0+1,1]=Q7-0.5
1740 GOTO 1800
1750 NC0+1,1]=P2-0.005
1760 GOTO 1800
1770 NC0+1,1]=P1*(0.995)
1780 GOTO 1800
1790 NC0+1,1]=Q9-0.5
1800 NC0+1,2]=L1-L2
1810 NC0+1,3]=M1-M2
1820 NC0+1,4]=(ATN(L1/B(1)))-ATN(L2/M4))*0.0174533
1830 NC0+1,5]=(ATN(M1/B(1)))-ATN(M2/M4))*0.0174533
1840 DISP NC0+1,1],NC0+1,2],NC0+1,3],NC0+1,4],NC0+1,5]
1850 NEXT 0
1860 NC22,1]=Q3
1870 NC22,2]=Q2
1880 NC22,3]=Q1
1890 NC22,4]=X1/10
1900 NC22,5]=X2
1910 NC23,1]=Q6
1920 NC23,2]=Q7
1930 NC23,3]=Q8
1940 NC23,4]=Q9
1950 NC23,5]=Q0
1960 NC24,1]=P1
1970 NC24,2]=P2*1000
1980 X9=27*(D-1)+9*(C-1)+3*(B-1)+A
1990 P4=ABS(NC1,2])
2000 P5=ABS(NC1,3])
2010 P6=ABS(NC1,4])
2020 P7=ABS(NC1,5])
2030 FOR S=1 TO 21 STEP 2
2040 IF (ABS(NCS,2])<P4) THEN 2060
2050 P4=ABS(NCS,2])
2060 IF (ABS(NCS,3])<P5) THEN 2080
2070 P5=ABS(NCS,3])
2080 IF (ABS(NCS,4])<P6) THEN 2100
2090 P6=ABS(NCS,4])
2100 IF (ABS(NCS,5])<P7) THEN 2120
2110 P7=ABS(NCS,5])
2120 NEXT S
2130 PRINT X9,P4,P5,P6,P7
2140 B1=-INT(LGT(P4+1E-12))
2150 B2=-INT(LGT(P5+1E-12))
2160 B3=-INT(LGT(P6+1E-12))
2170 B4=-INT(LGT(P7+1E-12))

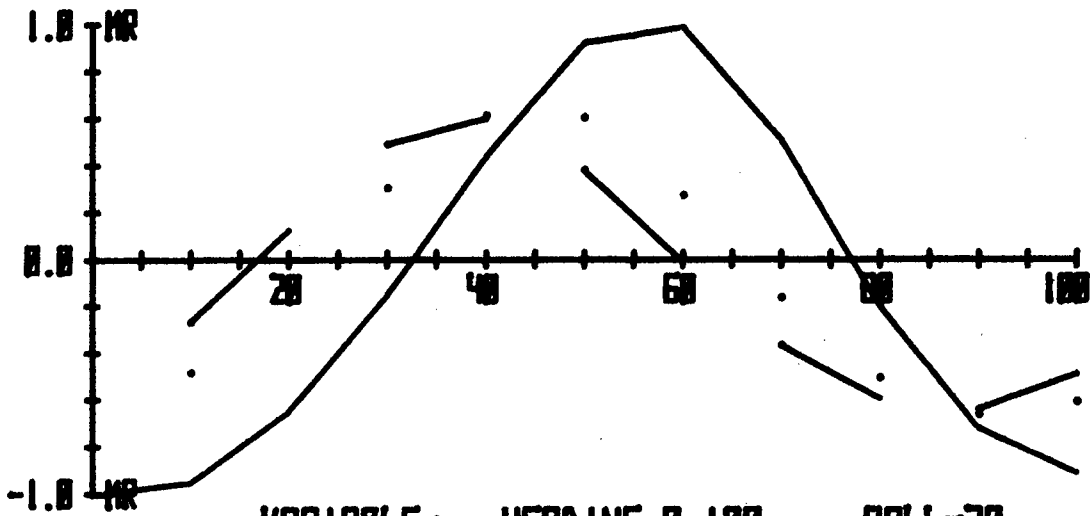
```

```
2150 FOR S=1 TO 21 STEP 2
2190 N[S,1]=10*N[S,1]
2200 N[S,2]=3000*N[S,2]*10+B1
2210 N[S,3]=3000*N[S,3]*10+B2
2220 N[S,4]=3000*N[S,4]*10+B3
2230 N[S,5]=3000*N[S,5]*10+B4
2240 NEXT S
2250 N[25,1]=3000+P4*10+B1
2260 N[25,2]=3000+P5*10+B2
2270 N[25,3]=3000+P6*10+B3
2280 N[25,4]=3000+P7*10+B4
2290 N[25,5]=X9
2300 N[26,1]=B1
2310 N[26,2]=B2
2320 N[26,3]=B3
2330 N[26,4]=B4
2340 STORE DATA X9,M
2350 NEXT A
2360 NEXT B
2370 NEXT C
2380 NEXT D
2390 END
```

LEAD X 2E-01



SUPER-EL X 5E-01



VARIABLE= HEADING 0-100 ROLL=30

30 MM AIRSPD=100MPS R-CLIMB=0  
 WIND=0 MUZZLE V=670.6 RANGE=3000  
 ALTITUDE=0 AIR DENSITY=1.00  
 PITCH=-20 0..... 10

APPLICATIONS OF SEQUENTIAL SENSITIVITY TEST STRATEGIES  
AND ESTIMATION USING A WEIBULL RESPONSE FUNCTION  
FOR EXTREME PROBABILITIES AND PERCENTAGE POINTS

Gertrude Weintraub

Concepts and Effectiveness Division

Ammunition Development and Engineering Directorate

Picatinny Arsenal

Dover, New Jersey

1. Abstract

Two applications of Dr. Einbinder's sequential sensitivity test strategy and estimation methodology for reliability assessments are discussed. Principal interest is in the determination of reliability at extreme low or high probability of response regions with a minimum number of tests. Empirical test data together with analysis and interpretation of the results of analysis are presented and conclusions drawn.

2. Introduction

Dr. S. Einbinder of Picatinny Arsenal devised a sequential sensitivity test strategy and estimation methodology. This procedure appears to be more efficient than other sensitivity methods in determining extreme percentage points of a response function.

Application of a One-Shot Transformed Response strategy and an Up and Down Transformed Response strategy to empirical problems are discussed.

The basic characteristics of a sensitivity test are: a stimulus, a test specimen and a response (0 or 1). Associated with each test is a critical stimulus or strength such that if the stimulus exceeds the strength, the specimen responds and vice-versa. The distribution of strength is called the response distribution or the response function. Based on quantal response data, we want to estimate the response function, the extreme percentage points and the probability of response at a critical level of the stress variable.

There exist several well known statistical techniques for treating a quantal response, but the method in (1) which is the Weibull Sensitivity Model and has been employed in the applications which follow has a number of advantages over the standard procedures. These advantages are the following:

- 1) Robust to unknown true response distribution.
- 2) Minimizes the need for variable transformations.
- 3) Capable of assuming a wide variety of distribution shapes which allows the approximation of many response curves, including the normal, over local regions and over the entire domain of the response function.

The main disadvantage of the Weibull sensitivity model is that it is a 3 parameter distribution, and the location parameter is sometimes difficult to estimate.

Two of the better known and frequently used sequential sensitivity test methods are the Up and Down Test (2) and the Langlie One Shot Test Strategy (3). For the Up and Down Test one item is tested at a time starting at the best initial estimate of the 50% response point. The



test level is moved up one step after each negative response and down one step after each positive response. The step size is fixed and must be determined in advance of the test. This method tends to concentrate the observations near the mean of the distribution. As a result, the method is generally good in estimating the mean or 50% point of a symmetric distribution but does not do too well with extreme percentage points.

Langlie developed a sequential test strategy that overcame the difficulty with the Up and Down method in predetermining the step size. This strategy makes use of continuously variable stress levels and is insensitive to the starting level and does not require specifying a prior step size. The analysis is based on a normal response distribution and has been shown to be more efficient than the Up and Down in estimating the mean and standard deviation of the response distribution.

Often, however, the experimenter is interested in the response function at the extreme ends of the distribution. This generally requires data to be obtained from the local region of interest.

Wetherill (4), in 1963, published the results of an investigation of sequential test methods for the estimation of general percentage points of a quantal response function. He found available procedures like the Up and Down to be unsuitable for estimation of extreme percentage points. He proposed a rule for transforming the response in an Up and Down Test so that observations would be concentrated in the tail areas. In Dr. Einbinder's test strategy, the Wetherill transformation is applied to the Langlie One-Shot test algorithm. This procedure is referred to as the One-Shot Transformed Response Strategy (OSTR for short).

The applications I shall describe feature an example of the Up and Down Transformed Response Strategy (UDTR for short) and the Langlie One-Shot Transformed Response Strategy. Estimation of the extreme percentage points is accomplished using a Weibull distribution as a response function. The basic rationale for the new test strategy and estimation methodology include testing in or close to the region of interest, using a variable level strategy, using a sequential strategy, using a locally best approximation if the response model is not known.

The new test strategy involves a transformation procedure which is defined in Tables 1 and 2. The transformation is defined by the value of  $N_0$  which determines the response quantile around which the test levels tend to concentrate. This quantile is called the transformed median percentage (TMP). For  $N_0=3$ , the TMP=79.32%. The response transformation is designed to make an increase in stress easier than a decrease. The greater the difficulty in decreasing the stress level, the greater will be the transformed median percentage. For  $P>.5$  as shown in Table 1, a positive response is denoted by an X or 1 and a negative response by 0. A type D response which requires a reduction in stress level is allowed to occur after  $N_0$  confirmations of a positive response. For  $P<.5$  the U's and D's are redefined as shown in Table 2.

A change of response type is said to occur when an alternation of response occurs. Wetherill proposed a stopping rule based upon a specified number of changes of response type rather than on a fixed number of trials. Based upon Wetherill's results, and our experience with this strategy, a minimum of 5-6 changes of response is advocated. The number of observations required in an experiment is a random variable with

TABLE 1

TRANSFORMED RESPONSE STRATEGIES

( $P > .5$ )

<u>NO</u>	<u>RESPONSE TYPE</u>		<u>TRANSF.</u>	<u>QUANTILE ESTIMATED</u>
	<u>D</u>	<u>U</u>		
2	XX	XO, O	P <sup>2</sup>	.7071
3	XXX	XXO, XO, O	P <sup>3</sup>	.7937
4	XXXX	XXXO, XXO, XO, O	P <sup>4</sup>	.8409

X→RESPONSE

O→NO RESPONSE

TABLE 2

TRANSFORMED RESPONSE STRATEGIES

(P<.5)

<u>No</u>	<u>U</u>	<u>RESPONSE TYPE</u> <u>D</u>	<u>TRANSF</u>	<u>QUANTILE</u> <u>ESTIMATED</u>
2	00	01	P2	.2929
3	000	001, 01, 1	P3	.2063
4	0000	0001, 001, 01, 1	P4	.1591
14	0000000000000000	0000000000000001, ETC.	P14	.0484

0 → NON-RESPONSE

1 → RESPONSE

this stopping rule. The expected sample size with a particular number of changes of response increases with  $N_0$  or the farther out in the tails of the response curve in which testing takes place.

### 3. Discussion

Next, we describe two actual applications of this new sensitivity test strategy.

#### 3.1 Objective

During the process of acceptance testing of an artillery fuze, it was found that the fuze armed at a distance of 10 feet from the gun muzzle. This condition was unsatisfactory since the fuze specifications required that no fuze arming occur at a distance of 10 feet from the muzzle.

A test program was subsequently undertaken to examine the fuze arming distance distribution in the lower tail in order to determine the following:

a. If the fuze specification acceptance test criterion for arming was reasonable for the fuze design.

b. If not, to decide on a suitable alteration which would provide the desired quality control on safe arming.

#### 3.2 Recommended Test Plan

In order to accomplish the desired objective, a statistical test program was designed, tailored to the new sequential sensitivity test strategy.

The objective was to determine the distribution of distances at which fuze arming occurs or conversely the distribution of target ranges at which fuze functioning does not occur. Primary interest was in ascertaining a safe gun-to-target distance which involved finding a distance at which a small probability of functioning would be expected to occur.

A One-Shot Transformed Response Sequential Sensitivity Test plan using an  $N_0=14$  was selected and implemented. Since fuze safety was the principal problem we were interested in defining the lower tail of the response distribution as accurately as possible within the limitations of time, hardware and cost. Using an  $N_0=14$  response strategy tended to concentrate the tests in the neighborhood of the lower 5% region of fuze arming. Simulation data previously conducted to estimate the required sample size indicated that about 150 tests would probably be needed to obtain 6 changes of response. Fuze function at a given range was defined as a positive response. One (1) represents fuze function and zero (0) is non-arming or non-function. The response must be defined such that an increase in stress level results in increasing the probability of a response. Then to obtain a type U response, we have to observe 14 tests conducted at a given target distance without arming, i.e., 14 zero responses before increasing the range to the target. If a fuze function was obtained at a given stress level or target range before a sequence of 14 zeros was completed, then a type D response is said to have occurred which required a decrease in target range.

Test limits were set at 0 and 100 feet from the gun. The first test level was set at 50 feet from the gun and testing continued **until** a fuze function occurred. The response was classified as type U or D according to the criteria described above. Testing was continued by setting each subsequent level of test halfway between a D and U response. If such an alternation **did** not occur, the procedure consisted of going back in the sequence of outcomes until an equivalent number of D's and U's were found. The next test level is the average of the stress levels corresponding to these outcomes. Where U's and D's could not be averaged (i.e., where

an equivalent number of D's and U's were not obtained) subsequent levels were averaged by using the lower limit for a type D response and the upper limit for a type U response. Testing continued until all of the 150 rounds were tested. These results are shown in Table 3.

Analysis of test data from the 150 rounds showed the point estimate of probability of arming to be .002 at 10 feet and the upper 95% confidence level of probability to be .010. With these probabilities of arming in mind, the fuze engineers decided to test fire an additional 40 rounds at 10 feet, hoping to get no arming. Much to their dismay, 2 rounds out of 40 tested at 10 feet, were found to arm. This result is not considered to be inconsistent with the previous performance estimates resulting from analysis of the test data from the 150 rounds. Thus, if the probability of functioning is .010 as estimated from the 150 rounds, the probability of observing 2 functions out of 40, given that the probability of functioning is .010, is .060.

Test data from the 40 rounds were subsequently aggregated with the other 150 data values and revised probabilities were obtained. The estimate of the probability of arming at 10 feet was estimated to be .015 as a point estimate and the upper 95% confidence level of probability was estimated to be .037.

The following conclusions were drawn from the analysis:

- 1) The current fuze design cannot meet the Mil-Standard non-arming requirement at 10 feet, with any high degree of reliability.
- 2) Either the arming distance acceptance test requirement has to be changed or the design modification to accommodate a 10 foot arming distance characteristic.

TABLE 3

JEFFERSON PROVING GROUND

M503 FUZE TEST RESULTS - April 1974

<u>I</u>	<u>STIMULUS (ft)</u>	<u>RESPONSE</u>	<u>RESPONSE TYPE</u>	<u>NUMBER OF CHANGES</u>
1	50.0000	0		
2	50.0000	1	D	
3	25.0000	0		
4	25.0000	0		
5	25.0000	0		
6	25.0000	0		
7	25.0000	0		
8	25.0000	0		
9	25.0000	0		
10	25.0000	0		
11	25.0000	0		
12	25.0000	0		
13	25.0000	0		
14	25.0000	0		
15	25.0000	0		
16	25.0000	0	U	1
17	37.5000	1	D	2
18	31.2500	0		
19	31.2500	0		
20	31.2500	0		
21	31.2500	0		
22	31.2500	0		
23	31.2500	0		
24	31.2500	0		
25	31.2500	1	D	
26	15.6250	0		
27	15.6250	0		
28	15.6250	0		
29	15.6250	0		
30	15.6250	0		
31	15.6250	0		
32	15.6250	0		
33	15.6250	0		
34	15.6250	0		
35	15.6250	0		
36	15.6250	0		
37	15.6250	1	D	
38	7.8130	0		
39	7.8130	0		
40	7.8130	0		

1 = Function  
0 = Non-Function

U = 14 (0's)  
D = 13 (0's), 1 etc.



TABLE 3 (CONT'D)

JEFFERSON PROVING GROUND

M503 FUZE TEST RESULTS - April 1974 (Continued)

<u>I</u>	<u>STIMULUS (ft)</u>	<u>RESPONSE</u>	<u>RESPONSE TYPE</u>	<u>NUMBER OF CHANGES</u>
41	7.8130	0		
42	7.8130	0		
43	7.8130	0		
44	7.8130	0		
45	7.8130	0		
46	7.8130	0		
47	7.8130	0		
48	7.8130	0		
49	7.8130	0		
50	7.8130	0		
51	7.8130	0	U	3
52	11.7190	0		
53	11.7190	0		
54	11.7190	0		
55	11.7190	0		
56	11.7190	0		
57	11.7190	0		
58	11.7190	0		
59	11.7190	0		
60	11.7190	0		
61	11.7190	0		
62	11.7190	0		
63	11.7190	0		
64	11.7190	0		
65	11.7190	0	U	
66	21.4850	0		
67	21.4850	0		
68	21.4850	0		
69	21.4850	0		
70	21.4850	0		
71	21.4850	0		
72	21.4850	0		
73	21.4850	0		
74	21.4850	0		
75	21.4850	0		
76	21.4850	0		
77	21.4850	0		
78	21.4850	0		
79	21.4850	0	U	
80	29.4930	0		

1 = Function  
0 = Non-Function

U = 14 (0's)  
D = 13 (0's), 1 etc.

TABLE 3 (CONT'D)

JEFFERSON PROVING GROUNDM503 FUZE TEST RESULTS - April 1974 (Continued)

<u>I</u>	<u>STIMULUS (ft)</u>	<u>RESPONSE</u>	<u>RESPONSE TYPE</u>	<u>NUMBER OF CHANGES</u>
81	29.4930	1	D	4
82	25.4890	0		
83	25.4890	0		
84	25.4890	0		
85	25.4890	0		
86	25.4890	0		
87	25.4890	0		
89	25.4890	0		
90	25.4890	0		
91	25.4890	0		
92	25.4890	0		
93	25.4890	0		
94	25.4890	0		
95	25.4890	0	U	5
96	27.4950	0		
97	27.4950	0		
98	27.4950	0		
99	27.4950	0		
100	27.4950	0		
101	27.4950	0		
102	27.4950	0		
103	27.4950	0		
104	27.4950	0		
105	27.4950	0		
106	27.4950	0		
107	27.4950	0		
108	27.4950	0		
109	27.4950	0	U	
110	38.7980	1	D	6
111	33.1470	0		
112	33.1470	1	D	
113	29.3180	0		
114	29.3180	0		
115	29.3180	1	D	
116	20.5190	0		
117	20.5190	0		
118	20.5190	0		
119	20.5190	0		
120	20.5190	0		

1 = Function

0 = Non-Function

U = 14 (0's)

D = 13 (0's), 1 etc.

TABLE 3 (CONT'D)

JEFFERSON PROVING GROUND

M503 FUZE TEST RESULTS - April 1974 (Continued)

<u>I</u>	<u>STIMULUS (ft)</u>	<u>RESPONSE</u>	<u>RESPONSE TYPE</u>	<u>NUMBER OF CHANGES</u>
121	20.5190	0		
122	20.5190	0		
123	20.5190	0		
124	20.5190	0		
125	20.5190	0		
126	20.5190	0		
127	20.5190	0		
128	20.5190	0		
129	20.5190	0		
130	24.9190	1	U	7
131	22.7190	0	D	8
132	22.7190	0		
133	22.7190	0		
134	22.7190	0		
135	22.7190	0		
136	22.7190	0		
137	22.7190	0		
138	22.7190	0		
139	22.7190	0		
140	22.7190	0		
141	22.7190	0		
142	22.7190	0		
143	22.7190	0		
144	22.7190	0		
145	23.8190	0	U	9
146	23.8190	0		
147	23.8190	0		
148	23.8190	0		
149	23.8190	0		
150	23.8190	0		
151	10.0000	0		
152	10.0000	0		
153	10.0000	0		
154	10.0000	0		
155	10.0000	1		
156	10.0000	0		
157	10.0000	0		
158	10.0000	0		
159	10.0000	0		
160	10.0000	0		

1 = Function  
 0 = Non-Function  
 U = 14 (0's)  
 D = 13 (0's), 1 etc.

TABLE 3 (CONT'D)

JEFFERSON PROVING GROUNDM503 FUZE TEST RESULTS - April 1974 (Continued)

<u>I</u>	<u>STIMULUS</u> <u>(ft)</u>	<u>RESPONSE</u>	<u>RESPONSE</u> <u>TYPE</u>	<u>NUMBER OF</u> <u>CHANGES</u>
161	10.0000	0		
162	10.0000	0		
163	10.0000	0		
164	10.0000	0		
165	10.0000	0		
166	10.0000	0		
167	10.0000	0		
168	10.0000	0		
169	10.0000	0		
170	10.0000	0		
171	10.0000	0		
172	10.0000	0		
173	10.0000	0		
174	10.0000	0		
175	10.0000	0		
176	10.0000	0		
177	10.0000	0		
178	10.0000	0		
179	10.0000	0		
180	10.0000	0		
181	10.0000	1		
182	10.0000	0		
183	10.0000	0		
184	10.0000	0		
185	10.0000	0		
186	10.0000	0		
187	10.0000	0		
188	10.0000	0		
189	10.0000	0		
190	10.0000	0		

1 = Function  
0 = Non-Function

3) Without having conducted the fuze tests in the prescribed sequential manner, the arming response distribution at the lower end could not have been determined with the same precision using the limited sample size.

In the next application of sensitivity testing, the objective was to determine the minimum quantity of propellant charge required to eject a projectile from a gun tube. An Up and Down Transformed Response (UDTR) was utilized, since a limited number of projectiles were available for test, and it was impractical to vary the test levels in a continuous manner.

A sequential sensitivity test program was conducted by varying the levels of propellant charge volume for low zone firing. Interest was focused on predicting the probability of projectile sticking when a complete low zone propellant charge is employed.

In the loading of a projectile into a gun tube, the projectile is rammed into the tube after which a propellant charge is employed to eject the projectile from the gun tube. When the propellant charge is insufficient to expel the projectile, the latter sticks in the gun tube causing an unsafe and undesirable condition.

Our problem was to evaluate the probability of sticking for a standard projectile and a modified version of the standard projectile when a complete low zone propellant charge is used. The standard projectile served as a baseline for comparing the new projectile.

### 3.3 Test Plan

A sequential sensitivity test plan was designed to vary propellant charge volume by a delta of 10 oz. starting at approximately 1/2 low zone propellant charge volume.

An Up and Down Transformed Response (UDTR) sequential sensitivity test procedure was implemented. The response strategy of  $N_0=4$  for 6 changes of response, requiring approximately 30 rounds was utilized in the interest of expediency and limitations on hardware. A type D response consisted of the outcomes (1111) while a type U response consisted of (1110), (110), (10), or (0) where 0= a sticker and 1= non sticker.

Tables 4 & 5 show actual test results obtained during the test program from tests conducted on projectiles 1 and 2. Tests on projectile 1 were conducted in accordance with an  $N_0=4$  strategy and 6 changes of response stopping rule. The delta used was 5 oz. instead of the originally intended 10 oz. and close to the end of the test program the delta was reduced to 2.5 oz. in order to obtain an overlap region of test results (e.g. sticker and non-sticker). Tests on projectile 2 did not conform to the prepared test strategy but rather to an inverse sampling procedure (where several tests were conducted with a given charge volume before decreasing charge volume for subsequent tests). The test data resulting from these tests consisted of quantal responses which were amenable to analysis using our Weibull model.

Results of analysis of test results from projectiles 1 and 2 are shown in Figure 5. The curves show the 90% percentile of non-stick to be 32 oz. or 38% of full charge volume for projectile 2 vs. 58 oz or 68% of full charge volume for projectile 1 (full charge was 85%). The modified design (Projectile 1) showed a greater propensity to sticking at less than full charge volume. However, extrapolating the estimated response functions to full charge volume, the probability of sticking at

TABLE 4

TEST DATA  
PROJECTILE 1  
CHAMBER  
CHARGE

<u>ROUND NO.</u>	<u>WEIGHT (OZ.)</u>	<u>RESPONSE</u>	<u>RESPONSE TYPE</u>	<u>NO. OF CHANGES</u>
1	56	0	U	
2	61	1		
3	61	1		
4	61	1		
5	61	1	D	1
6	56	1		
7	56	1		
8	56	1		
9	56	1	D	
10	51	0	U	2
11	56	0	U	
12	61	1		
13	61	1		
14	61	1		
15	61	1	D	3
16	56	0	U	4
17	61	1		
18	61	1		
19	61	1		
20	61	1	D	5
21	58.5	1		
22	58.5	1		
23	58.5	1		
24	58.5	1	D	
25	57.25	0	U	6
26	58.5	1		
27	58.5	1		
28	58.5	1		

=5 oz.

1 = Non-Sticker  
0 = Sticker

D = 1111  
U = 1110, 110, 10, 0

TABLE 5

TEST DATA  
PROJECTILE 2

<u>ROUND NO.</u>	<u>CHAMBER CHARGE WEIGHT (OZ.)</u>	<u>RESPONSE</u>
1	85	1
2	85	1
3	85	1
4	85	1
5	62.5	1
6	36.5	1
7	36.5	1
8	31.7	1
9	30.4	1
10	30.4	1
11	30.4	1
12	30.4	1
13	30.4	1
14	30.4	1
15	30.4	0
16	30.4	0
17	30.4	0
18	29.2	1
19	29.2	1
20	29.2	0
21	29.2	0
22	29.2	0
23	26.8	1
24	26.8	0
25	26.8	0
26	26.8	0

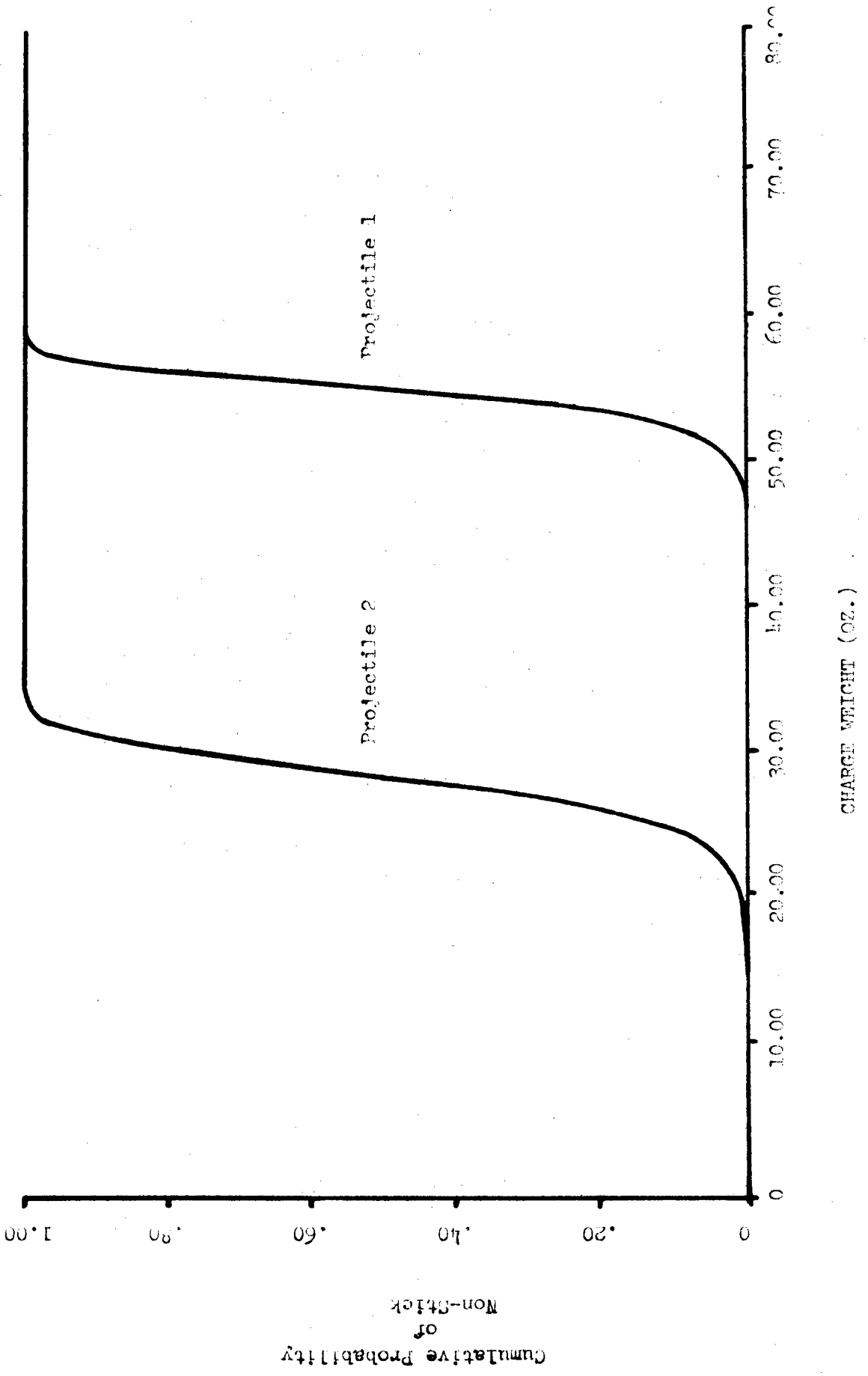
1 = Non-Sticker  
0 = Sticker



FIGURE 1

Weibull

Projectile 1 vs. Projectile 2



full charge for each of the projectiles was estimated to be 1 in a billion. Clearly, to verify such small probability would require an extremely large number of tests at full charge (in the order of 22,000 tests with no stickers in order to validate a probability of stick of 1 in 10,000).

#### 4. Summary and Conclusion

The two applications referred to herein represent actual examples of the successful implementation of the Wetherill (UDTR) and Einbinder (OSTR) sequential sensitivity test procedures and the Weibull response model. The OSTR procedure has also been applied to evaluate fuze detonator safety by determining the distribution of out-of-line distances for non-propagation of the explosive train.

Other applications of the test procedure have been implemented. For example, it has recently been used for estimating ballistic limit distributions of penetrators. In this connection, the procedure was used to estimate hazard velocity levels for plastic fragments in terms of perforating 1 cm. gelatin blocks.

In summary, similar sequential sensitivity test programs have been used rather successfully in quantitatively assessing the effect of environmental treatments and design changes on munition functioning and safety. In each instance, the effect of a single variable is assessed by allowing that variable to vary by discrete levels and obtain responses at each level of test.

Particularly has this new method been helpful in estimating the response function locally over some low or high region of interest. It also affords estimates of percentage points of the response distribution

and probabilities of response at specified levels of a stress. Our computer program produces point estimates and confidence level estimates of reliability and percentage points.

#### REFERENCES

1. Einbinder, S. K. "Reliability Models and Estimation In Terms of Stress - Strength"- Doctoral Dissertation, June 1973.
2. Dixon, W.J. and Mood A.M. "A Method for Obtaining and Analyzing Sensitivity Data, "J. Amer. Statist. Assoc. Vol 43, pp. 109 - 126, 1948.
3. Langlie, H.J. "Reliability Test Method for 'One-Shot' Items, " Proceedings of the Eighth Conference on the Design of Experiments in Army Research Development and Testing, ARO-D Report 63-2, pp. 145 - 165, 1963.
4. Wetherill, G. B. "Sequential Estimation of Quantal Response Curves." J. Royal Statistical Soc.; B, Vol. 25 pp. 1-48, 1963.

STATISTICAL ANALYSIS AND MODELING OF SENSITIVITY AUGMENTATION  
IN CUTANEOUS COMMUNICATIONS

R. D'Accardi and H. S. Bennett

US Army Electronics Command, Fort Monmouth, New Jersey

ABSTRACT. Since about 1965, the US Army Electronics Command has supported several investigations dealing with a new method of communications by which information transfer takes place through excitation of the peripheral nerve endings located in the dermis. The system involves skin stimulation by an electrical pulse transmitted in a Morse code-like pattern. Two small electrode pins mounted in a plastic holder attached to the subject's forearm provided the signal mechanism. One type of data was obtained when a cutaneous "cuing" signal was used as a precursor in the standard Fairbanks Rhyme audio test in order to test its ability to increase aural acuity.

The object of this presentation is threefold. First, we discuss the design of the experiment, classification of subjects, and techniques for sensitivity augmentation (electrical excitation of the peripheral nerve endings in the dermis). Secondly, we present statistical estimates of (a) the effects of the controlled variables (i.e., level of awareness, and audio noise level) upon response, and (b) the independence of these estimated effects. Thirdly, we present a realistic two-dimensional characterization of aural acuity with cutaneous "cuing," over a range of values, for a prescribed level of confidence, within which valid values of the model parameters may be found.

Among other things, cutaneous communication is intended to strengthen and enhance present audio and visual electronic communications by "alerting" communicators in a tactical environment to the fact that a standard audio or visual message will follow. In this regard, the information obtained from the statistical analysis of the effects of "cuing" should provide useful information on man-machine-interface characteristics for future design of such "cued" communication systems.

INTRODUCTION. The general goal of cutaneous communications is to provide an effective means of improving and supplementing present tactical communications, especially in a noisy environment. A system of this nature could be used for:

1. Warning signals
2. Alerting or cuing signals
3. Coded message traffic
4. Priority one-way communication

It can be applied to sentry operations, Airborne or Airmobile operations, Army Aviation support, small unit Reconnaissance, and Armored Operations where noise and distractions from a tactical environment may adversely affect the performance of radio operators and comcenter personnel. In rapidly developing situations and reconnaissance where privacy, radio silence, or back-up communications links are demanded, pre-coded messages can be used in lieu of normal radio means for command and control of small units or individual soldiers. Cuing signals used as a precursor to standard message formats can be of use to armor and helicopter operations which by their very nature are "noisy". Communications personnel can, therefore, be alerted to message traffic which can save time and decrease the probability of operator error.

In developing the concept for cutaneous communication, several problems had to be resolved.\* Work by Bennett, Hennessy and McCray(1) determined these parameters through a series of pilot experiments which were designed to determine the effects on sensitivity levels when electrode configurations, pulse width, pulse frequency, and pulse type were varied. Other experiments were conducted to (a) determine if one could detect individual pulses of various word rates; (b) determine effects of different metals on threshold feeling and discomfort; (c) determine the use of "shadow signals" to enhance individual acuity; and (d) determine, optimally, the lowest possible signal power to produce sensation on the skin. The results of their work are well documented(2,3) and they show the optimal signal which proved the most efficient, both from the viewpoint of minimization of power and acuity of response, was a bi-phasic rectangular pulse of 0.25 msec duration applied at a 300 pps rate, using a pin-type electrode of surgical steel with constant current in the .33 to 0.5 ma range at 10 to 30 volts excitation. With this information, a series of experiments were conducted using a cutaneous "cuing" signal as a precursor signal to the auditory Fairbanks Rhyme Test. These experiments were concerned with the effects of two variables (level of awareness, and acoustic noise) at several levels. The level of awareness (cuing signal) was compared with the recognition of a random selection of phonemes both in the presence of masking electrical noise, and in a noise-free environment. It remained to determine whether or not "cuing" improved the accuracy of phoneme recognition in the presence of noise. This paper is concerned with the analysis and modeling of these effects.

---

\*In order to be "optimal" such a system had to excite the double layer of Na<sup>+</sup> and K<sup>+</sup> ions which surround the nerves in the dermis. This means that parameters such as electrode configuration, optimal power requirements, pulse shape, and pulse duration have to be determined before the system becomes a reality.

DESIGN OF THE EXPERIMENT. The experiment was conducted at Fort Monmouth, New Jersey, where the standard Fairbanks Rhyme test was administered to eight subjects. The test consisted of a random selection of voiced and unvoiced stops, fricatives, and liquids and semi-vowels. There were two familiarization sessions and eight data acquisition sessions taken over a five-day period. All subjects were screened for normality of binaural hearing and for other medical requirements as prescribed by the staff at Patterson Army Hospital. The familiarization sessions consisted of electrocutaneous cuing and auditory reception and transcription of 250 phonemes. Data acquisition sessions consisted of the same process accompanied by several treatments or levels of "excitation" and "noise". The first familiarization sessions conditions were equivalent to a "no-noise" environment. The second was a "noisy" environment. For each of the ten sessions, the cutaneous sensation threshold level, (CSTL), of each subject was determined prior to testing. After each page of 50 phonemes, the threshold was rechecked and reset if necessary. Thus, for each session of 250 phonemes, for each subject, there are five distinct threshold measurements from which the level of the variable, % CSTL, was calculated.

The Fairbanks Rhyme test was "taped" and administered to simulate both the "No-noise" and "noisy" environments. Therefore, in the preliminary analysis of the data, we were concerned with the effects of two variables at two levels, where the combination of two levels of CSTL and noise are compared using the correct phoneme recognition as the joint response variable for all subjects. The experiment was well suited for the  $2^2$  factorial design with replication. A possible model for this randomized design is:

$$Y_{ij} = \mu + A_i + B_j + AB_{ij} + E_{ij} \quad (1)$$

where:  $A_i$  = CSTL (cuing factor at 0% CSTL and at 125% CSTL),

$B_j$  = Environmental factor (no-noise and noisy),

$AB_{ij}$  = Interaction of main effects,

$E_{ij}$  = Experimental error, and

$Y_{ij}$  = Correct phoneme response for all subjects.

The subjects were divided into two groups of four each. Each group was prepared with one familiarization session, and tested with four sessions of 250 phonemes. At the "0" noise and -5 dB noise levels; information was recorded once per session giving a replication of four observations. The results herein pertain to the group II subjects.

ANALYSIS OF VARIANCE. The group II data was used to determine if phoneme recognition is improved in the presence of environmental (acoustic) noise with cutaneous cuing. As previously mentioned, two levels of CSTL were chosen, i.e., 0% CSTL and 125% CSTL, to simulate cue and no-cue conditions. Likewise, two levels of environment were defined, i.e., two S/N ratios corresponding to

no-noise and noisy conditions respectively. The response variable is correct phoneme response, i.e., recognizing the phoneme B, given B as the stimulus, etc. The model chosen for this randomized design is:

$$Y_{ij} = \mu + A_i + B_j + AB_{ij} \pm E_{ij}$$

where the variables are defined as in equation (1) above. The effect of each factor is defined as the change of response variable produced by either a change in the levels of  $A_i$ ,  $B_j$ , or both.

Table 1 shows the treatment combinations and the associated measured responses.

CSTL - Cuing Level				
		0%	125%	Totals
ENVIRONMENT	No Noise (+5dB S/N)	60	56	464
		60	62	
		62	62	
		54	48	
	236	228		
Noisy (-5dB S/N)	52	54	404	
	38	50		
	54	56		
	44	56		
188	216			
TOTALS	424	444	868	

Table 1 - Treatment Combinations

The responses have been normalized to indicate the percentage of correct phoneme response to the nearest per cent. From this data, the following ANOVA was calculated:

Source	Degrees of Freedom	Sum of Squares	Mean Square Error	F Ratio
CSTL	1	25.0	25.0	0.84
Environment	1	225.0	225.0	7.58
Interactions	1	81.0	81.0	2.73
Error	12	356.0	29.67	----
Total	15	687.0		

From this information at the 95% level of significance, using  $F_{1,12}(.95) = 4.75$  from the standard F distribution, it is obvious that environment is significant and has a strong effect on correct phoneme response. From the interactions, it is apparent that the various combinations of environment and cuing are not significant. This is interpreted as an indication that at least a 5 dB improvement in effective S/N ratio is realized. In other words, performance remains essentially the same in a noisy environment with and without cuing, whereas with no-cuing there is a significant deterioration in performance observed when going from a no-noise to a noisy environment.

REGRESSION MODEL. In an effort to arrive at a realistic two-dimensional regression model which would describe any possible sub-liminal effects, i.e., changes in performance at say 50% and 75% CSTL, the following linear model was considered:

$$Y_t = B_0 + B_1 X_{1t} + B_2 X_{2j} + B_3 X_{1t} X_{2j} + E_{ij}$$

where  $Y_t$  = correct phoneme response

$X_{1t}$  = level of CSTL

$X_{2t}$  = level of environmental noise.

The level,  $X_{2t}$ , was designated either 0 or 1 to correspond to low and high levels of noise, and  $X_{1t}$  levels are 0.00, 0.75, 1.00, and 1.25 respectively. The purpose of this model was to establish a mathematical relationship to describe the effect of varying CSTL in either environment. That is, to determine response as  $X_1$  is varied from 0, to 1.25 in the steps indicated. The intent was to map any possible sub-liminal effects occurring below the threshold of sensation. Assuming the true relationship between environment, cuing, and response is linear, then the failure of the observed values to lie on the straight line is a function of experimental errors. If the differences are also the result of an inadequate model, then a higher order model would have to be formulated. Assuming the linear model adequate, the least squares estimates of the parameters, the respective 95% confidence bounds for  $B_i$ , and estimates of standard error are:

i	$\hat{B}_i$	C.I.	$S_B$	$S_{\hat{y}}$
0	56.6	$\pm 3.7$	2.1	-
1	2.5	$\pm 4.8$	2.8	-
2	-24.3	$\pm 5.3$	6.2	-
3	17.0	$\pm 5.9$	6.9	-
	-	-	-	5.6



This provides the model:

$$\hat{Y}_i = 56.6 + 2.5X_{1t} - 24.3X_{2t} + 17.0X_{1t}X_{2t}$$

Testing for linearity, the sum squared error and respective d. f. (lack of fit) for the variation of  $\hat{Y}_i$  from a straight line is 29.7 and  $df = 2$  respectively. If the model is correct, the residual mean square has the expected value of  $\sigma_y^2$ . Using  $S^2 = \sigma_e^2 = 31.78 = MS_e$ , the "F" ratio:

$$F = \frac{MS_L}{MS_e} = \frac{14.36}{31.78} = 0.45$$

and is not significant since it is less than unity. Thus, on the basis of this test at least, we have no reason to doubt the adequacy of the model and one can use  $S_e^2 = 31.78$  as an estimate of  $\sigma_y^2$ . Further, in examining the residuals,  $(\hat{Y}_i - Y_i)$ , and plotting them against  $\hat{Y}_i$ , one can see that no abnormality is indicated, that is, (a)  $\epsilon_i \sim N(0, \sigma_e^2)$ , (b) the variance is fairly constant and there is no need for weighted least squares or transformations on the  $Y_i$ , and (c) model appears adequate. See figure (1).

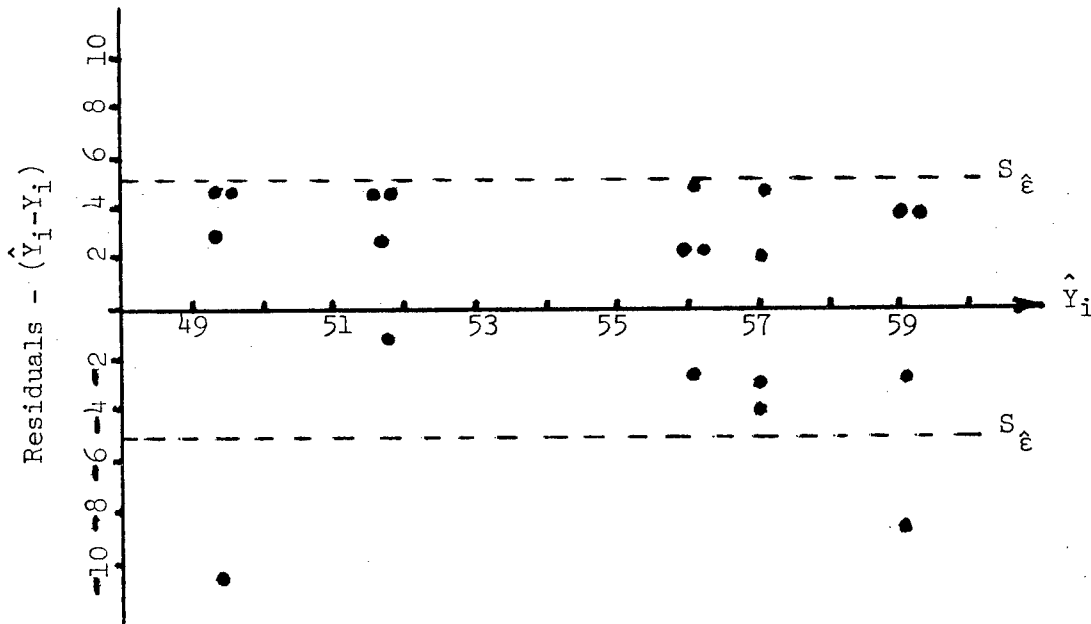


Figure 1 - Residuals

Therefore, a valid conclusion is that this linear two-dimensional model adequately describes response as a function of the two independent variables,  $X_{1t}$  and  $X_{2t}$ . This technique is presented to show the feasibility of simple least squares regression in dealing with this type of man-machine interface problem.

A more sophisticated modeling approach will be attempted at a later time when more data becomes available.

#### REFERENCES

1. J. M. McCray et al, "Cutaneous Communications", US Army Electronics Command Technical Report # ECOM-3303, Ft. Monmouth, N.J., June 1970.
2. Bennett, H. S., et al, "The Role of Skin Impedance in Cutaneous Communications", Proceedings of the 19th Conference on Engineering in Medicine and Biology, San Francisco, Calif., Nov. 1966.
3. Bennett, H. S., and J. R. Hennessy, "The Characteristics of the Cutaneous Communications Channel", IEEE International Conference on Communications, Minneapolis, Minn., June 1967.

# MULTIVARIATE DATA ANALYSIS

Herbert Solomon  
Stanford University

## 1. Introduction

There has always been a need to achieve parsimonious yet operationally meaningful accounts of what is going on in nature and in human behavior. We are aware of attempts by biologists to classify flora and fauna, and even that dichotomy was a major step forward. It is in the physical and life sciences that we find the first quantifiers at work on such matters. Later we find social anthropologists and psychologists engaging in studies on how groupings can be accomplished. Today we find numerical taxonomy pervasive in practically every field of study. This has been spurred by increased activity in data collection and developments in computer technology. Multiple measurements on elements, individuals, or variables abound nowadays, and one sees investigators scurrying about to apply discriminant analysis, classification or clustering techniques, multidimensional contingency table analysis, factor analysis, and with good reason. We will return to these topics.

Even though we regard classification in social sciences as rather new, it is difficult to think of its counterpart in physical sciences as very old unless one thinks of a few hundred years in the course of mankind as a very long step. It was just two or three hundred years ago that many physical ailments were labeled "consumption", because they were characterized by a "wasting away of the tissues". Under this were

lumped such diseases as leprosy, tuberculosis, diabetes, and others. It was not until some time later that someone noted that the urine of some of these sufferers was sweet and that of others was not. Of course, the subsequent discoveries of two different bacilli for leprosy and tuberculosis suggested finer groupings that obviously were more meaningful in connection with specific treatments.

There is a lesson here for all of us, namely that the classification and grouping of individuals or elements based on data analyses of sets of variables can lead to man-made group concoctions that are artificial and sometimes misleading. What should be kept in mind is that when this is done, a grouping has some meaning to the investigator. For the last forty years or so, aberrant mental behavior has been subjected to classification and groupings produced on the basis of observations made on any number of variables. For an individual placed in one of these groupings, some treatment is suggested. I imagine one does not feel as comfortable here in a diagnosis as in the case of diabetes or tuberculosis groupings at present; and rightfully so. Yet treatment will be undertaken based on a diagnostic category to which an individual is assigned. This should give us pause when classification is attempted by data analysis in the newer investigations such as those that occur, for example, in the reenlistment decision in the armed services.

## 2. History

It is in the late 19th century that we find a blossoming of inquiries into classification through the selection and appropriate use of manifest variables. Quite often a one-dimensional index that

incorporates all pertinent variables was sought so that a technician could assign an individual to one of several groups based on his responses to the variables employed. For example, the coefficient of racial likeness was an index developed at the turn of the century to distinguish different national or tribal groups on the basis of a set of physical measurements. Inquiries on association of criminal types with physical measurements of individuals also received attention in this period by such investigators as Lombroso.

Much of this inquiry took place in the British community of scholars. In a way it might be viewed to have begun at least in a larger sense with Charles Darwin's vast collection of data arising from his travels around the world. His diaries presented many observations on the animal kingdom and served as a base for study by many who came later in the 19th century.

It was with these investigators in the last quarter of the 19th century that we have the beginnings of statistical contributions to classification. In fact, it is the classification problem that in a way motivated and created statistical inference as an area of scientific inquiry. The modern discipline we now call statistics was brought about by the anthropometrists, biologists, and psychologists of that era. Such initial contributors to modern statistics as Francis Galton and Karl Pearson stem from that period.

Galton seemed to be perpetually engaged in data analysis. He and his cousin, Darwin, and others revolved in an age of scientific inquiry that emphasized empiricism. Pearson, along with others, later attempted quantification and mathematization from the empirical analyses provided

by their colleagues. Galton, whom we regard as the founder of regression analysis through his study on relationships between children's heights and parents' heights, also initiated and developed the notion of correlation prior to 1885. The correlation coefficient serves as a basic summarization in multivariate data analysis and consequently in studies that go into techniques of grouping. From its very nature, obviously a high correlation coefficient would indicate that the two variables belong in a group and a low correlation would suggest that they do not.

In one of his papers in 1888, Galton became interested in the classification problem. He pointed out that 12 measures proposed by Bertillon to be used for classification of criminals were not independent and suggested that the observed measurements be transformed into a set of independent measures. He also suggested the method of transformation, which we can now view as simple or unweighted summation in factor analysis. Thus quite early we see the intermingling of classification analysis and factor analysis - and of course this is still quite current. We will return to factor analysis and its place in classification analysis.

Pearson was engaged in studies that were obviously related to classification. In an interesting paper in 1901, he discussed mathematical representations of lines and planes of closest fit to systems of points in space. This geometrical way of looking at the classification problem may present a neater view of the problem to some. In effect, the multi-dimensional observations at hand, e.g., age, IQ, schooling, number of dependents, rank, length of enlistment, etc., for each member of a

population of  $N$  members up for reenlistment decision can be viewed as  $N$  points in a 7-dimensional space. Moreover, each point cannot be reached by traveling along 7 perpendicular axes, for the 7 variables can and usually have degrees of association which must be taken into account.

This effort is a fundamental problem in multivariate data analysis, namely finding a grid of orthogonal axes to replace the grid of correlated axes (naturally the points remain where they are). If the number of dimensions can be reduced to two or three, some ease is achieved since elements can be grouped by eye. In fact, this is related to one of the central problems in factor analysis and is pertinent to the use of factor analysis as a classification technique.

### 3. Assignment Procedures and Discriminant Analysis

It is now important to be specific about the term "classification". For our purposes, we will assume that the term comprises both the clustering of data into groups and the assignment of data to previously specified groups. Actually, the latter can be valued as a subset of the former. In the former category, we require the data to produce both the number of groupings or clusters and the assignment of each element or individual to these groupings. In the latter category, the number of groups or clusters is predetermined. Each group is labeled, and rules are designed on the basis of which an assignment of each element is made to one of the fixed groups.

We do not wish to convey a sharp distinction between clustering and assignment procedures. If a classification procedure is not producing meaningful groups through the assignments that are made, then changes are called for, namely revising the predetermined groupings either in

number or in shape or in both on the basis of the new information. This sequential revision of groups on the basis of the data available at different times suggests that one is indirectly engaging in clustering procedures. On the other hand, it is wise to keep in mind the conceptual differences just mentioned between attempts at clustering and attempts at assignment.

An essential step in classification procedures is the representation of the relationships among the variables on which data has been collected. Among other important and prior steps, there are the processes of developing numbers to measure phenomena, making decisions on the employment of nominal, ordinal or continuous data, and subsequent coding of this data for analysis. In this paper, we do not review these issues, but we are mindful of their impact on the data analysis that will undergo investigation. Thus, we return quickly to clustering and assignment techniques and the basic summarizations of data for these purposes.

The clustering and assignment problems, even though they were recognized for some time, did not possess any techniques until rather recently. The assignment problem received the first thrust. The analysis was provided by one of the great savants of modern statistical inference, namely R. A. Fisher. In a paper in 1936, we find what is now Fisher's classic work on discriminant analysis. It is entitled "The Use of Multiple Measurements in Taxonomic Problems" and was published in The Annals of Eugenics. The author was to say somewhat later that the paper was written to embody the working of a practical numerical example arising in plant taxonomy in which the concept of a discriminant function seems to be of immediate service. This is a simple but fascinating statement, because



it demonstrates once again that when there is a problem requiring solution some strides can be made. Too often we find solutions looking for a problem, and this is something we should be especially concerned with in classification problems.

In his paper, Fisher also listed the basic data he analyzed. This is rarely done by authors, and so we find the Fisher data and just a few other data bases referred to time and time again by subsequent authors who are experimenting with new assignment or clustering techniques. In this way, an anchor is provided against which the results of other techniques can be assessed.

The data employed by Fisher was supplied by a botanist, and it represented measurements on the irises of the Gaspé Peninsula. This data was previously published in the Bulletin of the American Iris Society and was therefore not a likely contender for a best seller. Since it is a classical piece in the statistical literature, let us look at it in some detail. Four measurements on each of fifty plants in each of three iris categories were obtained. The categories are: *Iris Virginica*, *Iris Versicolor*, and *Iris Setosa*. For each of the 150 plants already assigned to one of three categories, there are measurements of sepal length, sepal breadth, petal length, and petal breadth.

If we refer back to our geometrical representation, we have 150 points scattered in a four-dimensional space, except that each point is already labeled as belonging to one of three groups. The question is whether in some neat and simple way we can separate the 50 points belonging to any one group from the other two sets. This is compounded by the fact, in this case, that two of the irises, namely *Versicolor* and *Virginica*,

actually have a specific genetic relationship and obviously, then, do have some overlap. In other words, Fisher is looking for hyperplanes that partition the four-dimensional space, and after partitioning, hopefully leave each group inviolate. Algebraically, he is asking for a linear function of the four measurements (later called the discriminant function) that accomplishes this. As a reasonable index for determining the coefficients of the linear function, he suggests one that will maximize the ratio of the difference between the means to the standard deviations within species. To be specific, let  $d_p, p = 1, 2, 3, 4$  represent the difference in the observed means.

Then for any linear function,  $X$ , of the measurements, namely

$$X = \lambda_1 x_1 + \lambda_2 x_2 + \lambda_3 x_3 + \lambda_4 x_4$$

the difference between the means of  $X$  in the two species is

$$D = \lambda_1 d_1 + \lambda_2 d_2 + \lambda_3 d_3 + \lambda_4 d_4$$

while the variance of  $X$  within species is proportional to

$$S = \sum_{p=1}^4 \sum_{q=1}^4 \lambda_p \lambda_q S_{pq}$$

where  $S_{pq}$  is the sum of squares or products in  $X_p$  and  $X_q$ .

The particular linear function that best discriminates the two species will be one for which the ratio  $D^2/S$  is greatest, by variation of the four coefficients  $\lambda_1, \lambda_2, \lambda_3, \lambda_4$ . Geometrically we are locating the hyperplane that best separates two groups of points in the sense that the distance between the four-dimensional centroids is greatest. Even though there are three groups of irises, in effect Fisher acts as

if there are two groups, since *Iris Versicolor* and *Iris Virginica* are genetically tied together. Note that the variations within species is assumed to be the same in this development.

The index that is employed to provide the delineation is tied at first to the multivariate normal structure assumed for each species. Yet it is very similar to the indexes suggested by strict multivariate data analysis as we will see in the next section. Here we are maximizing the difference between the centroids of the two species of irises, or, in other words, maximizing heterogeneity between groups. This theme will carry through all of our attempts of classification. Either we will maximize heterogeneity between groups or minimize the scatter (i.e., seek homogeneity) within groups.

As a result of the analysis, Fisher arrives at a linear discriminant function that accomplishes a nice separation. For example, *Iris Setosa* is separated completely from *Versicolor* and *Virginica*. It turns out that only one of the four measurements is really necessary to do this, namely petal length, and this can probably be seen by just looking at the 150 sets of measurements. This should be something for us to highlight, especially when we get into data sets for which meanings are not so specific and measurements are not so commensurate. This will obviously be so in any number of studies in criminal justice.

Fisher's work has been extended to assign an element to any one of  $k$  groups, and computer programs exist in Computer Center libraries to accomplish multiple linear discriminant analysis. Attached to this subject is the question of how many variables should be used in a discriminant function. It is obvious that the more variables one uses, the better the discrimination should be, but it is also obvious that the

marginal gain in using additional variables can decrease sharply and therefore some variables can best be omitted in the interests of parsimony. Thus we seek the best discriminating variables.

We might also ask what one would do if one were faced with the 150 irises and did not know their groupings; that is, if we had only the four measurements on each, and we wished to see what number of groupings as well as assignments could be made. Here we are no longer faced with the assignment problem alone, but with the clustering problem or grouping problem, which of course subsumes an assignment problem. It is to this topic that we now turn.

#### 4. Data Summarization

It is important in talking about grouping to consider whether we are grouping measurement variables or individuals or elements of a population. For the iris data, we are grouping elements of a population. Quite often, one is interested in grouping measurement or test variables. The basic data summarization in multivariate data analysis will depend on whether we are grouping variables or elements. We will resolve this in subsequent discussion by first going in some detail into the data summarization question.

There are several ways to begin the data summarization. All give a picture of data interrelationship, but each has special reasons for its employment by an investigator. One representation is that of the scatter matrix. Here we portray the total scatter or dispersion displayed by  $n$  individuals or elements each measured on  $p$  variables ( $n$  points in a  $p$ -dimensional space) by a matrix with  $p$  rows and  $p$  columns where an element in the  $i^{\text{th}}$  row and  $j^{\text{th}}$  column, say  $t_{ij}$ , is

the sum of the  $n$  cross products of measurements (taken around the mean) on variable  $x_i$  with measurements (taken around the mean) on variable  $x_j$ . In brief,

$$t_{ij} = \sum_{k=1}^p (x_{ik} - \bar{x}_i)(x_{jk} - \bar{x}_j), \quad t_{ij} = t_{ji}, \quad \bar{x}_i = \frac{\sum_{k=1}^n x_{ik}}{n}.$$

Let us label this matrix  $T$ . Naturally an element in the main diagonal, say  $i^{\text{th}}$  row and  $i^{\text{th}}$  column, is the sum of the squares of the deviations of  $x_i$  from its mean. If  $p = 1$ , then  $T$  is a scalar, namely

$$\sum_{k=1}^n (x_k - C)^2 \quad \text{where } C = \frac{\sum_{k=1}^n x_k}{n}.$$

If each element in the scatter matrix  $T$  is divided by  $n$ , the resulting matrix is the covariance matrix with cell entries  $s_{ij}$  and we label this  $K$ . Now if we also divide each element,  $s_{ij}$ , in  $K$  by the standard deviations of  $x_i$  and  $x_j$ , the resulting element  $r_{ij} = s_{ij}/s_i s_j$  is the correlation coefficient between  $x_i$  and  $x_j$  and the resulting matrix is now the correlation matrix which we label  $R$ .

An important advantage of  $T$  is the manner in which it can be decomposed into two matrices that are especially pertinent in clustering and classification studies. In a classification study, the  $n$  elements will be assigned to  $k$  predetermined groups. Each group with, say,  $n_i$  elements can be viewed as a universe with its own scatter matrix formed as before and labeled  $W_i$ . If we sum all the  $W_i$  scatter matrices, we get  $W = \sum_{i=1}^k W_i$  and let this represent the within scatter

or homogeneity of the groupings. Likewise, if for each of the  $k$  groups, we compute the group mean (a  $p$ -dimensional vector where the  $r^{\text{th}}$  coordinate is the mean value based on the  $n_r$  observations for  $x_r$ ) and then produce the  $(p \times p)$  matrix that we label  $B$ , for it expresses a measure of the "betweenness" or heterogeneity of the  $k$  groups. The central point in this development is the existence of the fundamental matrix equation

$$T = W + B .$$

This result suggests immediately an index by which classification (predetermined number of groups) can be evaluated and, by extension, how clustering can be terminated at some cluster size. For any given data set  $T$  is fixed. Thus measures of "groupiness" or "clusteriness" as functions of  $W$  and  $B$  are thrust forth for examination.

For  $p = 1$ , the matrix equation reduces to an equation about scalars. Thus a good grouping index is one which minimizes  $W$  or equivalently maximizes  $B$ . We may also consider maximizing either the ratio  $B/W$  or  $T/W = 1 + B/W$ . An added benefit is that this ratio is invariant under linear transformations of the data. Statisticians have long exploited this fact, for  $B/W$  multiplied by an appropriate constant is the familiar  $F$  ratio in the analysis of variance.

When the number of measurements per element is two or more ( $p > 1$ ), grouping criteria are not so straightforward. Several possibilities suggest themselves and have been developed and studied by investigators. One criterion suggested by several authors that is a quite natural index is the minimization of the trace of  $W$  (sum of all elements in

the main diagonal of the matrix) over all possible partitions into  $k$  groups. This is equivalent to maximizing Trace B because

$$\text{Trace } T = \text{Trace } W + \text{Trace } B \quad .$$

However, Trace W is invariant only under an orthogonal transformation and not under non-singular linear transformations.

Another criterion that may be employed for  $p > 1$  is the ratio of the determinants

$$|T|/|W| = |1 + W^{-1}B| \quad .$$

We can use  $|T|/|W|$  as a criterion for grouping and select that grouping for which this index is maximized, or equivalently  $|W|$  is minimized. Also we may employ  $\log(|T|/|W|)$  since it is a monotonic function.

Another criterion for grouping is the trace of  $W^{-1}B$  and we select the grouping that maximizes this index. This index has been used as a test statistic in multivariate statistical analysis as has the ratio  $|W|/|T|$ . The latter was employed by Wilks to test whether groups differ in mean values, and the former has been put forth by Hotelling in some situations and by Rao as a generalization of the Mahalanobis distance between two groups for  $k > 2$  groups. We will shortly define and discuss the implications and uses of the Mahalanobis distance in clustering procedures.

Both Trace ( $W^{-1}B$ ) and  $|T|/|W|$  may be expressed in terms of the eigenvalues,  $\lambda_i$ , of the matrix  $W^{-1}B$ . We write

$$|T|/|W| = \prod_{i=1}^p (1 + \lambda_i)$$

and

$$\text{Trace } W^{-1}B = \sum_{i=1}^P \lambda_i$$

where  $\lambda_i$  are the roots of the determinantal equation,  $|B-\lambda W| = 0$ . The characterization of these ratios in terms of eigenvalues is helpful in data representation especially when the effects of some reduction in dimensionality is desired. All the eigenvalues of this equation are invariant under non-singular linear transformations of the data. It can be proved that these eigenvalues are the only invariants of  $W$  and  $B$  under non-singular linear transformations.

#### 5. Distance Matrix

Thus far we have discussed some summarizations of multivariate data in matrix form, either  $T$  (scatter),  $K$  (covariance), or  $R$  (correlation) and the kinds of grouping criteria that are suggested by the  $T$  format. Intuitively, we see that any grouping criterion is a function of homogeneity within groups and heterogeneity between groups and the indexes already described are specific quantities embodying these notions. We shall discuss other indexes as we proceed, but each will be a function of homogeneity within groups and heterogeneity between groups in which attempts will be made to minimize the former, maximize the latter, or in effect do both. For the correlation coefficient index, large values indicate homogeneity; small values indicate heterogeneity.

Another method of summarizing data that is more appropriate on occasion is to find the distance between each pair of the  $n$  points in the  $p$ -dimensional space. This leads to a representation in matrix



form of an  $n \times n$  matrix where each element, in the  $i^{\text{th}}$  row and the  $j^{\text{th}}$  column, say  $d_{ij}$ , is the distance in the  $p$ -dimensional space between the  $i^{\text{th}}$  element or individual and the  $j^{\text{th}}$  element or individual. All the elements in the main diagonal are zero. The distance matrix is akin to the correlation matrix in that both may be viewed as similarity matrices - the jumping-off place for clustering attempts.

The decision as to whether correlation matrices or distance matrices are to be employed is usually determined by the problem at hand. If  $n$  individuals or  $n$  elements are to be grouped on the basis of  $p$  measurements on each, then the  $n \times n$  distance matrix is the natural summarization; if the  $p$  measurement variables are to be grouped on the basis of the measurements on  $n$  individuals or  $n$  elements, then the  $p \times p$  correlation matrix is the natural summarization of the data. This latter matrix is the natural beginning point in factor analysis where parsimony in the number of latent measurement variables is a desired goal. We will return to factor analysis and its place in clustering in subsequent sections. In some taxonomic situations the question of which measure of similarity to employ, whether it is of the association or distance type, will require some thought. While we will touch on these points, these inquiries will not be featured in this exposition.

The notion of a distance matrix will be placed in sharper focus, and this will be done by some discussion of appropriate distance measures. Because we will normally think of our data bases for clustering individuals or elements as  $n$  points in a  $p$ -dimensional space, the distance measures usually appropriate and available are Euclidean distance and Mahalanobis distance. The Euclidean distance between individuals or elements with

respect to all  $p$  measurement variables may be written in vector notation

$$d_{ij}^2 = (P_i - P_j)'(P_i - P_j)$$

where  $d_{ij}$  is the Euclidean distance between individual  $i$  and individual  $j$ ,  $P_i$  and  $P_j$  are column vectors each with  $p$  rows listing the  $p$  measurements on the  $i^{\text{th}}$  and  $j^{\text{th}}$  individuals respectively. The product of the difference row vector  $(P_i - P_j)'$  by its transpose is a scalar. This is the distance function with which most of us are familiar. The Mahalanobis distance may be written as in the notation above as

$$m d_{ij}^2 = (P_i - P_j)' W^{-1} (P_i - P_j)$$

where  $W^{-1}$  is the inverse matrix of  $W = \sum_{i=1}^k W_i$  and  $W_i$  is obtained for each of the  $i = 1, 3, \dots, k$  groups by

$$W_i = \sum_{m=1}^m (P_{mi} - C_i)(P_{mi} - C_i)'$$

Note that a grouping of elements is necessary to compute  $W_i$  and consequently  $W$ . Thus the Mahalanobis distance takes into account the associations or interrelationships in the measurement variables. If two measurement variables are highly correlated, the Euclidean distance can be misleading because of the equal weight it imposes inaccurately on each measurement variable, but this will not be so with the Mahalanobis distance. The Mahalanobis distance is more tedious to compute and for

a long time it was avoided for this reason alone, but the computer has brought it within reach. Actually if each of the correlations between the measurement variables is low, the error in employing the Euclidean distance is not damaging. As a rule of thumb, correlations as high as 0.5 will not produce Euclidean distances that lead to operational difficulties.

Other distance measures appear in the literature. The Minkowski distance is the name applied to all distance measures that are of the form

$$d(i,j) = \left\{ \sum_{m=1}^P |x_{im} - x_{jm}|^n \right\}^{1/n} .$$

We have discussed the case  $n=2$ . When  $n=1$ , the label "city-block" distance is sometimes employed and it may be relevant for some distance situations.

## 6. Clustering

We now look at the clustering side of classification analysis. Our main emphasis will be on clustering as an exploratory device. Development of assignment procedures is for those who already enjoy the luxury of knowing the groups that exist. We will place ourselves in the situation where a body of multidimensional data has been collected by some investigator and he wishes to decipher what kind of structure, if any, underlies the data collected. A wide variety of techniques have been suggested and attempted. They run the gamut from looking at all possible partitionings of the data to trying to zero in on an optimal partitioning without having to look at too much of all the possibilities. The former method is a "dumb" procedure which

is workable if the computer can quickly look at everything, and of course this is not so even for a small number of observations in a small number of dimensions. Thus we sacrifice optimal partitioning for what we hope are suboptimal partitions that can be achieved much more cheaply.

Let us consider one general way of looking at the problem considered by several authors. We start with any given partition into  $g$  groups. Consider moving a single object into every group other than the one it is in. If no move will create a partition for which a clustering criterion is increased, leave the object where it is. Otherwise, move it so that the maximum increase in the criterion occurs. Naturally, we are assuming the existence of a reasonable criterion. Using the partition thus created, we process the second object in the same way, then the third, etc. After several passes, one will reach a point at which no move of a single object from the group it is in to a different group will cause an increase in the criterion function. At this point we say we have found a "local maximum" of our criterion function. This rarely takes more than a reasonable time on a computer. This has been labeled the "hill-climbing" pass algorithm by Friedman and Rubin.

They and others have suggested modifications. For example, we start with the best partition yet known. Then process one group at a time, in sequence, by placing each object of the group being processed into the outside group with nearest center of gravity, recalculating the criterion function after each move. This is done in order, the object nearest an outside group being moved first. Although the criterion initially decreases, it may at some point during the process achieve a value higher than previously found. This will especially be the case if the group

being processed consists of two clusters widely separated in space. After processing all the objects of one group, we restore the best partition yet found, and proceed to process the next group. This has been labeled a "forcing pass" algorithm. It is defined as the application of this procedure once to each group, in sequence. Forcing passes are repeated until they produce no improvement. These passes are relatively fast, compared to hill-climbing, since we need not evaluate every possible move for an object.

Still another procedure proposed by Friedman and Rubin and others involves starting with a partition  $Q$  (we use the best partition currently known) and reassigning each object to the group with nearest center of gravity. The value of the newly formed partition is then calculated. With either of the other two criteria just discussed, we use the metric defined by the matrix  $W^{-1}$  computed from the partition  $P$  -- i.e.,  $d(P, C_k) = (P - C_k)W^{-1}(P - C_k)^T$ . The centers of gravity  $C_k$  and the scatter matrix  $W$  are maintained as those of the original partition  $Q$  until all  $n$  objects have been reassigned, at which time new values for  $C_k$  and  $W$  are computed. This contrasts with hill-climbing, for which the partition and the derived  $W$  change with each move of an object.

The reassignment of each object in the above manner is termed a "reassignment pass". Reassignment passes are repeated until a partition with higher value is no longer achieved. Sets of forcing passes and reassignment passes are alternated until neither produces improvement, and then hill-climbing is resorted to for a new local maximum. Other modifications are also applied, but when it proves impossible to reach a higher local maximum, the procedure is terminated. If one is willing and

financially able to spend the computer time, one can repeat the entire procedure using another starting partition chosen at random or, as we will soon see, obtained by a quick step-wise method. The forcing and reassignment passes are fast, but only occasionally helpful. Restarting from each of several random partitions or the step-wise solution is slow but provides more confidence in the result.

## 7. Initial Partitioning

There is a much simpler way of initiating clustering. It was proposed by King and in effect gives a quick initial partitioning of the data whether it be measurement variable groupings or delineation of individuals in a population. Either something of interest and use to the investigator appears quickly, or what does emerge can serve as the first step for those algorithms that require a start upon which various kinds of iterations are attempted. These were just described in the previous section.

The procedure proposed by King is a step-wise clustering procedure. This is its principal asset because it leads to a simple and quick algorithm that involves  $(n-1)$  scannings of a correlation matrix based on  $n$  variables. At each scanning or pass, the variables are sorted into a number of groups that is one less than at the previous pass. In this way, we obtain  $(n-k)$  groups of variables at the  $k^{\text{th}}$  scanning. The  $(n \times n)$  matrix can also be a distance matrix. In that case, we sort individuals or elements into groups.

The procedure operates as follows. We will employ the correlation matrix as our similarity matrix for expository purposes, and bring in the distance matrix when appropriate to highlight differences.

As a start, we can view the  $n$  variables as  $n$  groups, one variable to each group. Now scan the correlation matrix for the maximum cell entry (naturally without regard to sign). In a distance matrix we would seek the minimum distance cell entry. Suppose the maximum correlation is between variables  $X_i$  and  $X_j$ . Label it  $r_{ij}$ . We place  $X_i$  and  $X_j$  in the same group, and we now have  $(n-1)$  groups  $X_1, X_2, \dots, (X_i, X_j), \dots, X_{n-1}, X_n$ . This produces an  $(n-1) \times (n-1)$  correlation matrix, all pairs of correlation coefficients over the original  $(n-2)$  variables plus the correlations obtained by pairing each of these with the concocted variable  $X_i + X_j = Y_{ij}$ . Essentially, we are representing the group of two elements by its centroid.

On the second pass of what is now an  $(n-1) \times (n-1)$  correlation matrix, a third variable may join the group of two variables formed on the first pass if the correlation between it and  $Y_{ij}$  is maximum, or the maximum correlation value in the reduced correlation matrix may again involve two individual variables. Thus we would get either one group of three variables and  $(n-3)$  groups each containing one variable, or two groups each containing two variables and  $(n-4)$  groups each containing one variable. In either situation we merge variables and revise the correlation matrix as on the first pass. In the former case, the centroid of the group of three variables represents its group, and in the latter case, each group with two variables is represented by its centroid. Recall that we do not have to divide the sum of the variables by the number of variables to obtain the centroid because the correlation coefficient is invariant when one variable of the pair is always multiplied by the same constant.

Thus, at each pass, the two groups with the highest correlations are merged and the total number of groups to that point is reduced by one. After a variable has joined a group of variables, it cannot be removed from that group. In this way it is possible to miss an optimal grouping. This is very similar to selection of predictors in step-wise linear regression. It should also be mentioned that a group can lose its identity by merging with another group on a later pass. By the time all the scanning is completed we have produced successively  $(n-1)$ ,  $(n-2)$ ,  $(n-3)$ , ...,  $3, 2$  groupings.

The clustering index employed by King for measuring the worth of the grouping is that of minimum correlation (or maximal distance) between the group centroids when the scanning has placed the variables into two groups. This leaves something to be desired because it does not look at the effectiveness of the grouping when more than two groups are involved. He also reviews another index, suggested originally by Wilks for testing the mutual independence of  $k$  subsets of  $n$  multivariate normal random variables. In terms of what we described earlier in the paper, the index is the ratio of the determinants

$$Z = \frac{|T|}{\prod_{i=1}^k |W_i|}$$

where  $T$  is the scatter matrix defined previously and each  $W_i$  is the scatter matrix for each of the  $k$  groups.

This index has some nice geometrical and statistical properties. For example, when  $k=2$ ,

$$Z = \frac{|T|}{|W_1| \cdot |W_2|} = \prod (1-r_i^2)$$



where  $r_i$  is the  $i^{\text{th}}$  canonical correlation between the two sets of variables. This index may be viewed as a "generalized alienation coefficient" since it is an extension of  $1 - R^2$ , where  $R$  is the multiple correlation coefficient occurring when two groups have one variable in one group and  $(n-1)$  in the other. However, it is not too useful in some data analyses, especially in social science, because a number of data sets lead to quasi-singular correlation matrices and truncation error can give ridiculous results. For this reason, and possibly others, negative determinants appear and make it impossible to employ the Wilks index.

Let us look at the King method for two particular data bases. The first is in connection with a penalty jury decision in California, and the second is the iris data we discussed previously.

Individuals convicted of murder: 238 individuals convicted of first-degree murder in California over a recent ten-year period were studied on the basis of 25 measurements each as to whether an association existed between their 25-dimensional descriptions and the penalty decision that resulted in life imprisonment for 135 and capital punishment for 103. These 25 variables consisted of biographical information on the individual, description of the crime, information on defense counsel, the prosecution, and the judge. A King step-wise clustering procedure was employed to cluster the 238 individuals and then seek a substantive association, if any, between the characteristics of the individual, characteristics of the crime, judicial process, and the penalty decision. My thanks for the data under analysis go to several Law Review students at Stanford with whom I worked on this study. One of their major concerns was to see if there were any association between the penalty decided upon by a jury, which

under the law is given no instruction on standards to be employed in arriving at a decision, and socio-economic characteristics or racial and ethnic background of the individual. The clustering printout did not reveal any significant associations between penalty and whether the defendant was black, Mexican-American, or white; or whether the defendant was a blue-collar worker or not. At the 58th pass, there was one significant group that contained 18 members, all of whom had received the life penalty. As the number of passes increased, this group remained the principal group until the last few passes. At the 75th step the group contained 34 members, of whom 30 received life imprisonment. At the 100th step the group contained 42 life cases out of 62 members, and at the 125th step, the group contained 63 life cases out of 102 members-- a 62 to 38 percent mixture for all 238 cases. What we seem to be getting is clustering indicating very little or no association of penalty with defendant and judicial characteristics. This may also have judicial implications; for a penalty jury is, in effect, tossing for each defendant a coin which lands head or tail in a 55 to 45 percent ratio.

Irises: In Fisher's well-known paper on the linear discriminant function, he employed three groups of irises, each containing 50 members. Sepal width and length, petal width and length were obtained for each of the 150 irises--50 *Iris Setosa*, 50 *Iris Virginica*, 50 *Iris Versicolor*. We will assume only that we have 150 irises represented as points in a four-dimensional space which we wish to cluster by the King step-wise clustering scheme. The results are interesting. The *Iris Setosa* are quite different from the other two, which overlap a great deal. Thus we find at the 137th pass that there is a cluster of 48 members, each an *Iris Setosa*; there are

four clusters containing 23, 24, 17, and 24 members respectively, with 12, 4, 16, and 18 Iris Versicolor respectively, all demonstrating the natural overlap between Iris Versicolor and Iris Virginica. At the very next pass (138th) the two groups with 24 members each merge into a group with 48 members, 22 Iris Versicolor and 26 Iris Virginica. Thus when there is real and decided overlap the step-wise clustering scheme reflects it; but if we did not know of the original three groups, we would be hard pressed for a decision, and obviously would have to resort to additional techniques, or expertise, or both.

These data bases and several others are discussed in a paper by Solomon [11]. In that paper some computer printouts for the King procedure are displayed.

#### 8. Data Representation Techniques

An interesting idea in multivariate data analysis has been proposed by Chernoff [1]. It is a graphical data representation technique. In his procedure Chernoff transforms multidimensional vectors into human faces. Thus, for example, several hundred vectors are transformed into several hundred faces and the faces are then classified into groups according to the similarity perceived by the classifier. The theme here is that we are very familiar through experiences in life in classifying facial characteristics. In his paper Chernoff presents a computer program which handles up to 18-dimensional vectors. The reader is referred to his paper for more details.

Up to this point, we have mentioned factor analysis but not said much about it. There is an extensive literature on this subject. Its current use in multivariate data analysis is from the representation point

of view. Computer libraries have factor analysis programs which can take large order correlation matrices and obtain principal component solutions. In this way a large number of measurement variables, say 50 to 100, can be transformed into many fewer variables, say on the order of 5 to 10. Classification and clustering can then be applied to multidimensional vectors of very small order. A real payoff occurs when the largest two or three factors are employed, because a graphical display can then be arranged. When this occurs, clustering or classification of the data points can be achieved by eye. See Solomon [11] for more details.

#### 9. Multidimensional Contingency Table Analysis

A multivariate data analysis technique which is receiving more attention these days is that of multidimensional contingency table analysis (logistic response analysis). A number of authors (e.g., Kullback [8,9] and Goodman [6], among others) have done fundamental work on this technique. We will discuss this model by illustrating its use to study reenlistment decision in the armed services. The data stems from some recent Marine Corps analyses.

In this section the structure underlying contingency table analysis is discussed, and the mechanics of obtaining odds and probabilities for the reenlistment decision are illustrated. The reenlistment analysis is based on a large number of categorical variables. Regression analysis and similar multivariate techniques for continuous variables become inefficient and inappropriate for this situation. Multidimensional contingency table analysis, which we now explore, is more suitable.

We are interested in accounting for the variation in reenlistments in a parsimonious way and with meaningful factors. Consider a simple example with two factors, reenlistment decision and rank. Assume rank is categorized into two levels, i.e., high rank or low rank. The reenlistment decision and rank of forty individuals might produce the table

	High Rank	Low Rank
Reenlistment	10	10
No Reenlistment	10	10

which yields probability estimates

	High Rank	Low Rank
Reenlistment	.25	.25
No Reenlistment	.25	.25

or more generally

	High Rank	Low Rank
Reenlistment	$P_{11}$	$P_{12}$
No Reenlistment	$P_{21}$	$P_{22}$

The overall probability that a person reenlists is  $P_{11} + P_{12} = .5$ . The probability that a reenlistment is of high rank is also .5 for

$$\frac{P_{11}}{P_{11} + P_{21}} = \frac{.25}{.25 + .25} = .5$$

In this example, the probabilities of reenlistment are the same regardless of rank. This table suggests reenlistment decision and rank are independent.

A related measure denoted as an "odds" measure has an interpretation well known to bettors. In the above example, if one wagers that a person selected at random reenlists, the overall odds, i.e., the odds of reenlistment regardless of rank are one to one or even. Knowledge that the bet is on the high rank group or low rank group does not change the odds. Realistically, however, the probability and odds that a high rank and a low rank will reenlist are not the same. As an illustration, consider the table

	High Rank	Low Rank
Reenlistment	15	5
No Reenlistment	5	15

This gives probability estimates

	High Rank	Low Rank
Reenlistment	.375	.125
No Reenlistment	.125	.375

From this table the overall probability of a person reenlisting,  $.375 + .125 = .5$ , remains the same but the probability that a high rank reenlists is

$$\frac{.375}{.375 + .125} = .75$$

This differs substantially from the overall probability of 0.5 which no longer summarizes the data. The odds will change as well, being three to one for high rank, one to three for low rank. The information contained in this and the preceding table is described in terms of three

characteristics: the overall probability that a person will reenlist, the probability that a low rank will reenlist, and the probability that a high rank will reenlist.

The basic objective in a more complex table is to identify the minimum number of probabilities that must be specified to adequately describe the table. The specification of probabilities given in the last example can be used. However, recent research has developed a more formal descriptive model similar to analysis of variance or regression models. Instead of dealing directly with cell probabilities, it is convenient to deal with their logarithms. These new variables, the logarithms of the cell probabilities, have characteristics similar to measurement data, and they can be incorporated into a linear model whose parameters indicate the contribution of the various factors and their interactions to the cell probability.

The linear model for estimating logarithms of  $p_{tk}$  (for our analysis where we fix and employ only the marginals) is

$$(9.1) \quad \ln p_{tk} = \mu + \alpha_t^T + \alpha_k^K + \alpha_{tk}^{TK}, \quad t = 1, 2, \quad k = 1, 2$$

where  $\ln p_{tk}$  is the natural logarithm of  $p_{tk}$ . The constant  $\mu$  is a general mean indicating the average value of  $\ln p_{tk}$ . The parameter  $\alpha^T$  indicates the "effect" of reenlistment decision on  $\ln p_{tk}$  independent of rank;  $\alpha^K$  measures the effect of rank on  $\ln p_{tk}$  independent of reenlistment decision. The parameter  $\alpha^{TK}$  measures the interaction effect of reenlistment decision and rank on  $\ln p_{tk}$ . For the first example cited, where all the  $p_{tk}$  (and consequently all the  $\ln p_{tk}$ ) are equal,  $\alpha^T$  and  $\alpha^K$  are zero since  $\ln p_{tk}$  does not vary with either

reenlistment decision or rank; and for this reason, too,  $\alpha^{TK}$  is zero. Hence,  $p_{tk}$  is equal to the anti-log of  $\mu$ , which in this case is the overall probability that a person reenlists.

The model in (9.1) allows the step-by-step computation of cell probabilities similar to regression analysis. For example, if reenlistment decision is considered as a function of rank, the odds of reenlistment ( $t = 1$ ) to non-reenlistment ( $t = 2$ ) for a given rank are

$$\frac{p_{1k}}{p_{2k}}, \text{ say } k = 1 \text{ for high rank, } k = 2 \text{ for low rank.}$$

Using the model in (9.1) to obtain these odds in logarithmic form (denoted hereafter as the log odds), we get

$$(9.2) \quad \ln \frac{p_{1k}}{p_{2k}} = (\mu + \alpha_1^T + \alpha_k^K + \alpha_{1k}^{TK}) - (\mu + \alpha_2^T + \alpha_k^K + \alpha_{2k}^{TK}) = 2\alpha_1^T + 2\alpha_{1k}^{TK}$$

where  $\alpha_1^T = -\alpha_2^T$  and  $\alpha_{1k}^{TK} = -\alpha_{2k}^{TK}$ .

Since the  $\alpha$  parameters measure deviations from a general mean, a deviation from the mean at one level leads to a deviation in the opposite direction at the other level. Replacing  $2\alpha_1^T$  and  $2\alpha_{1k}^{TK}$  by  $\beta^T$  and  $\beta_k^{TK}$  to simplify the notation in (9.2) yields

$$(9.3) \quad \ln \frac{p_{1k}}{p_{2k}} = \beta^T + \beta_k^{TK}, \quad k = 1 \text{ for high rank, } k = 2 \text{ for low rank.}$$

From (9.3) the log odds of reenlistment to non-reenlistment are seen to depend on  $\beta^T$ , the general mean for the log odds, and  $\beta_k^{TK}$ , the relationship between rank and reenlistment decision.



To further illustrate these ideas, let us consider another example. Assume that reenlistment is dependent on two variables: length of enlistment,  $L$ , and the presence of absence of dependents,  $D$ . Then  $P_{t\ell d}$  represents the probability that a specified reenlistment decision is made given an individual's length of enlistment and dependency status. Following the previous example, the logarithm of the odds of reenlisting to not reenlisting as a function of the predictor variables can be written as

$$(9.4) \quad \ln \frac{P_{1\ell d}}{P_{2\ell d}} = \beta^T + \beta_{\ell}^{TL} + \beta_d^{TD} + \beta_{\ell d}^{TLD} .$$

Each one of the  $\beta$  parameters has the same interpretation given previously.  $\beta^T$  is a general mean for the log odds. The  $\beta_{\ell}^{TL}$ ,  $\ell = 1$  (two year enlistment),  $\ell = 2$  (three year enlistment),  $\ell = 3$  (enlistment of four or more years) are numerical measures of the impact on reenlistment of enlistment length. Similarly, the  $\beta_d^{TD}$  are numerical measures of the impact of dependents on reenlistment where the subscript  $d$  identifies the number of dependents,  $d = 1$  (no dependents),  $d = 2$  (one or more dependents). The parameters  $\beta_{\ell d}^{TLD}$  are interaction terms. It may be, for example, that the presence of dependents may influence the reenlistment decision of four year enlistees differently than that of three or two year enlistees. First, dependents are more common among four year enlistees and they tend to have more of them. Second, four year enlistees who serve to end of term tend to be older at the time they must decide whether to reenlist. Hence the impetus to reenlist may be greater among members of this group than would be indicated by adding

the separate effects of dependency status and length of enlistment. The presence of a joint interaction effect of length of enlistment and dependency status on reenlistment implies a non-zero  $\beta_{32}^{TLD}$ .

By exponentiation of each side of the log-linear model (9.4), the odds of reenlisting to not reenlisting (hereafter referred to simply as the odds of reenlistment) can be written in the form

$$(9.5) \quad \frac{P_{1\ell d}}{P_{2\ell d}} = \delta^T \delta_{\ell}^{TL} \delta_d^{TD} \delta_{\ell d}^{TLD}$$

where the  $\delta$ 's are the anti-logs of the  $\beta$ 's. In this form of the model,  $\delta^T$  can be interpreted as the overall mean odds of reenlistment which is modified by more detailed information about the levels or values of the predictor variables and their interactions.

For the full model, the overall odds  $\delta^T$  is estimated as

$$\hat{\delta}^T = e^{\hat{\beta}^T} = e^{-2.60} = .074 ,$$

that is, the odds are .074 to one in favor of reenlistment.\* If the odds of reenlistment are desired for Marines who enlist for four years, we need to compute

$$\hat{\delta}^T \hat{\delta}_3^{TL} = (.074) (2.46) = .182 .$$

---

\*Note that this is not the odds that would be computed directly from the observations, but rather from their logarithmic transforms, then averaging, then transforming back to the odds domain. Thus, this "mean odds" is a multiplicative mean, not an additive mean.

Thus, the odds of reenlistment increase from .074 to .182 for Marines who enlist for four years.

The calculation can be extended, for example, to Marines who enlist for four years who have one or more dependents by the end of their enlistment period. If these independent variables entered linearly in the model, the estimated odds for reenlistment would be given by

$\hat{\delta}^T \hat{\delta}_3^{TL} \hat{\delta}_2^{TD}$ , but since dependency status and length of enlistment are found to interact jointly on enlistment, the odds of enlistment for this group of individuals are given by

$$(9.6) \quad \hat{\delta}^T \hat{\delta}_3^{TL} \hat{\delta}_2^{TD} \hat{\delta}_{32}^{TLD} = (.074) (2.46) (1.72) (1.46) = .457 ,$$

where the last term measures the interaction effect of L and D .

Note, the odds of reenlistment for four year enlistees with one or more dependents would have been substantially underestimated if the first order interaction effect had been omitted from the calculation.

As can be seen from this example, the estimation of a small number of  $\delta$ 's permits the computation of odds of reenlistment for individuals having very diverse characteristics. It should be noted that as in the case of regression analysis, the coefficients of the linear model (9.4) (and consequently the  $\delta$ 's in (9.6)) show the effect of a change in a variable holding all the other variables constant. Thus  $\hat{\delta}_l^{TL}$  measures the direct effect of length of enlistment on the odds of reenlistment. If an indirect effect with dependency status is also present, this is measured by  $\hat{\delta}_{ld}^{TLD}$ . Both the direct and indirect effects of length of enlistment are net of the effects of other variables such as rank,

education, race, etc. That is, the effects of variation in the latter variables on the odds of reenlistment are taken into account in the computation of  $\hat{\delta}_{\ell}^{TL}$  and  $\hat{\delta}_{\ell d}^{TLD}$ .

Given the odds of reenlistment for individuals with a given set of characteristics, it is a simple matter to compute the probability of reenlistment for the group from the relationship

$$(9.7) \quad \text{Odds of reenlistment} = \frac{\text{probability of reenlisting}}{\text{probability of not reenlisting}} .$$

For example, if the probability of reenlisting,  $p$ , is .07, then the probability of not reenlisting,  $1-p$ , is .93, and the odds of reenlistment are .074 to one. Solving for  $p$  in (9.6) yields

$$(9.8) \quad \text{Probability of reenlisting} = \frac{\text{odds of reenlistment}}{1 + \text{odds of reenlistment}} .$$

In these calculations it is important to distinguish between individual  $\delta$ 's referred to as "odds factors" (e.g.,  $\delta^{TL}$ ,  $\delta^{TD}$ ,  $\delta^{TLD}$ ) which indicate how the overall mean reenlistment odds,  $\delta^T$ , is modified and the product of  $\delta$ 's (e.g.,  $\delta^T \delta^{TL} \delta^{TD} \delta^{TLD}$ ) which measures the odds of reenlistment for individuals with a specified set of characteristics. Since (9.8) converts the odds of reenlistment for a given group of individuals to the probability of reenlistment for that group, it cannot be applied to the individual  $\delta$ 's.

The above discussion makes clear that a large number of parameters may enter the contingency table model, thus raising the problem of identifying which parameters are to be included in a model and which are to

be excluded. Statistical distribution theory and a measure  $I^*$ , which is similar to  $R^2$ , the multiple correlation coefficient in regression analysis, is used to resolve this problem.

In regression analysis the explanatory value of a set of predictor variables is measured by the percentage of variation in the dependent variable explained by the predictor variables. The base measure of variation in regression analysis is the sum of squares about the mean of the dependent variable, i.e.,  $\Sigma(Y_1 - \bar{Y})^2$ . As predictor variables are added to the model, the predicted values of the dependent variable,  $\hat{Y}_1$ , are used to measure the amount of variation,  $\Sigma(Y_1 - \bar{Y})^2$ , explained. The percentage of base variation explained is then

$$100 R^2 = 100 \frac{\Sigma(Y_1 - \bar{Y})^2 - \Sigma(Y_1 - \hat{Y}_1)^2}{\Sigma(Y_1 - \bar{Y})^2}$$

One method of measuring the contribution of any particular variable is the change in  $R^2$  when that predictor variable is added to the model.

For contingency tables, the base measure of variation is computed either as the chi-square statistic\*

$$\Sigma \frac{(O - E)^2}{E}$$

or the information measure

$$2 \Sigma O \ln \frac{O}{E}$$

---

\*The symbol  $O$  stands for the observed cell count and  $E$  the estimated cell count. The summation is over all cells in a table.

under the hypothesis that all  $\beta$  parameters in (9.4) except the general mean are zero.  $I^*$  is then the percentage of base variation explained by the introduction of some collection of  $\beta$  parameters into the model, i.e.,

$$I^* = \frac{(\sum O \ln \frac{O}{E})_{\text{Base}} - (\sum O \ln \frac{O}{E})_{\text{Model}}}{(\sum O \ln \frac{O}{E})_{\text{Base}}}$$

In practice, an  $I^*$  of 70 percent or better is desired. Sometimes a lower value is acceptable because increasing  $I^*$  requires the addition of many interaction parameters with the consequent difficulty of interpretation. The prime objective is to find the most important parameters. When the number of observations is large, parameters signifying marginal impact will be statistically significant. Thus we may adopt a convention, say, of excluding parameters when they increase  $I^*$  by less than two percentage points.

### Bibliography

- [1] Chernoff, H. (1973), "The Use of Faces to Represent Points in k-Dimensional Space Graphically," J. Amer. Statist. Assoc., 68, pp. 361-8.
- [2] Fisher, R. A. (1936), "The Use of Multiple Measurements in Taxonomic Problems," Annals of Eugenics, Vol. VII, Pt. II, pp. 179-88.
- [3] Fortier, J. J. and Solomon, H. (1966), "Clustering Procedures," Multivariate Analysis, pp. 493-506 (ed. Krishnaiah, P. R.), New York: Academic Press.
- [4] Friedman, H. P. and Rubin, J. (1967), "On Some Invariant Criteria for Grouping Data," J. Amer. Statist. Assoc., 62, 1159-78.
- [5] Galton, Francis (1888), "Co-relations and Their Measurements, Chiefly from Anthropometric Data," Proceedings of the Royal Society, Vol. 45, pp. 135-40.
- [6] Goodman, L. A. (1971), "The Analysis of Multidimensional Contingency Tables: Stepwise Procedures and Direct Estimation Methods for Building Models for Multiple Classifications," Technometrics, 13, pp. 33-61.
- [7] King, B. F. (1967), "Step-wise Clustering Procedures," J. Amer. Statist. Assoc., 62, pp. 86-101.
- [8] Ku, H. H. and Kullback, S. (1968), "Interaction in Multidimensional Contingency Tables: An Information Theoretic Approach," Journal of Research of the National Bureau of Standards--Mathematical Sciences, 72B, pp. 159-99.
- [9] Kullback, S., Kupperman, M., and Ku, H. H. (1962), "An Application of Information Theory to the Analysis of Contingency Tables, with a Table of  $2n \ln n$ ,  $n = 1(1)10,000$ ," Journal of Research of the National Bureau of Standards--B. Mathematics and Mathematical Physics, 66B, pp. 217-43.
- [10] Pearson, Karl (1901), "On Lines and Planes of Closest Fit to Systems of Points in Space," The London, Edinburgh, and Dublin Philosophical Magazine and Journal of Science, Vol. 2 (6th Ser.), pp. 559-72.
- [11] Solomon, H. (1971), "Cluster Analysis," Mathematics in the Archaeological and Historical Sciences, Edinburgh University Press, pp. 62-81.

SKIP-LOT PROCEDURE FORMULATION USING THE  
SIMPLIFIED MARKOV CHAIN METHOD

Richard M. Brugger  
US Army Armament Command  
Product Assurance Directorate  
RAM Assessment Division  
Rock Island, Illinois

ABSTRACT. Skip-lot procedure formulations have previously been carried out by using complicated and tedious Markov chain methods. This paper describes a very short formulation method using a simplified Markov chain approach which was developed by the author for continuous sampling plan formulations, but which has application to the skip-lot problem also.

It is common practice in quality assurance to use a sampling plan to determine whether a lot of units should be accepted or not. For example, we might have a lot of size 100, and draw a sample of size seven. From this sample, we will make an inference about the lot, thereby enabling us to make a decision about what we should do with the lot; should we accept the lot or should we reject? The sampling plan will help us make this decision by providing us with the decision criteria. For example, we might have an attributes-type plan, whereby some characteristic of the unit of product, its paint job, for example, is judged to be either good or bad. Perhaps the sampling plan permits one of the seven units to be defective with the lot still being acceptable, but specifies that if two or more units are defective we must reject the lot.

Another general kind of plan is a variables plan, whereby some dimensional property of the unit, for example, diameter, is determined, and this measurement is included with other measurements to determine perhaps a sample mean and standard deviation, with which suitable tables can be consulted to determine whether the lot should be accepted or not.

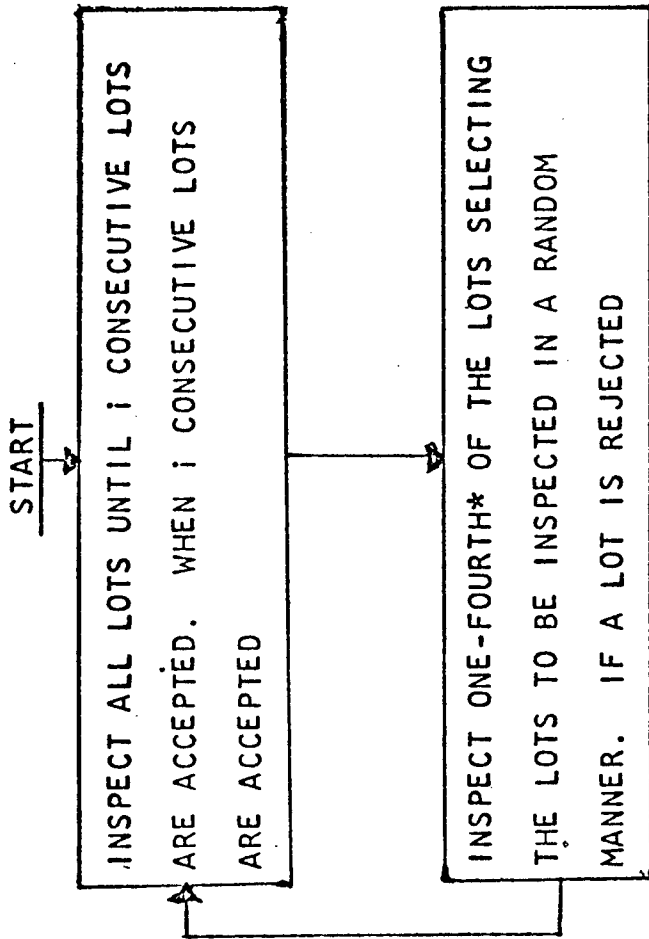


In what will follow, we are not especially concerned about what kind of lot sampling plan we are dealing with, since our discussion will apply to any lot sampling plan. We don't care if it is by attributes or variables, nor whether the plan is single, double, multiple, sequential, or what have you, with the sole requirement that it must be a plan whereby a decision is made on a lot from an inference reached in a sample.

Now let's take a look at a skip-lot procedure. Figure 1 provides an example of a very simple one, patterned after the continuous sampling plan CSP-1 of Harold Dodge [4, 5]. Note that the rules of the procedure tell us that if five consecutive lots are accepted, we may thereafter use some probabilistic device such as dice or random numbers to determine whether we should inspect a lot; we want the probability that a lot will be inspected in this example to be one fourth. Note that we have also provided the cautionary statement "provided there are no indications that factors are present which would have caused homogeneity to be lost". Obviously, if we found that a serious machine malfunction had developed while a lot was being run through it, we would not want to skip the inspection on the lot. If homogeneity is lost, or if a lot is rejected, we return to the 100% phase, after which the cycle goes on and on.

In this example then, we see what the skip in skip-lot means - we skip the inspection or testing of some lots. Why do we want to do this? The economic factor is usually the significant reason. For example, in using a skip-lot procedure for ballistic testing, over seven and one half million dollars were saved by the Army in the period from 1966 through 1973. This is described by Charles E. Stine [11]. Since skip-lot procedures are analogous to continuous sampling plans, much of the mathematical theory of continuous sampling applies also to skip-lot procedures. The first work in continuous sampling was carried out by Dodge. As the types of plans generated over the years became more and more complicated, the direct algebraic approaches of Dodge were not sufficient for determining such properties of interest as average fraction inspected curves and average outgoing quality curves.

FIGURE 1



\*PROVIDED THERE ARE NO INDICATIONS THAT FACTORS ARE PRESENT WHICH WOULD CAUSE HOMOGENEITY TO BE LOST.

These problems were overcome with the introduction by Lieberman and Solomon [8] of the theory of Markov chains into the continuous sampling plan area. Markov chain methods were thereafter used a great deal in problems in continuous sampling plan theory; their methods then logically carried over into problems of skip procedure theory. As a matter of fact, Allen Endres [6], an employee of mine at the time, presented a paper at the Thirteenth Conference on the Design of Experiments using Markov chains to determine the mathematical properties of a rather complicated skip procedure. Two recent papers by Perry [9, 10] in the Journal of Quality Technology make use of Markov chain methods to describe skip-lot procedures.

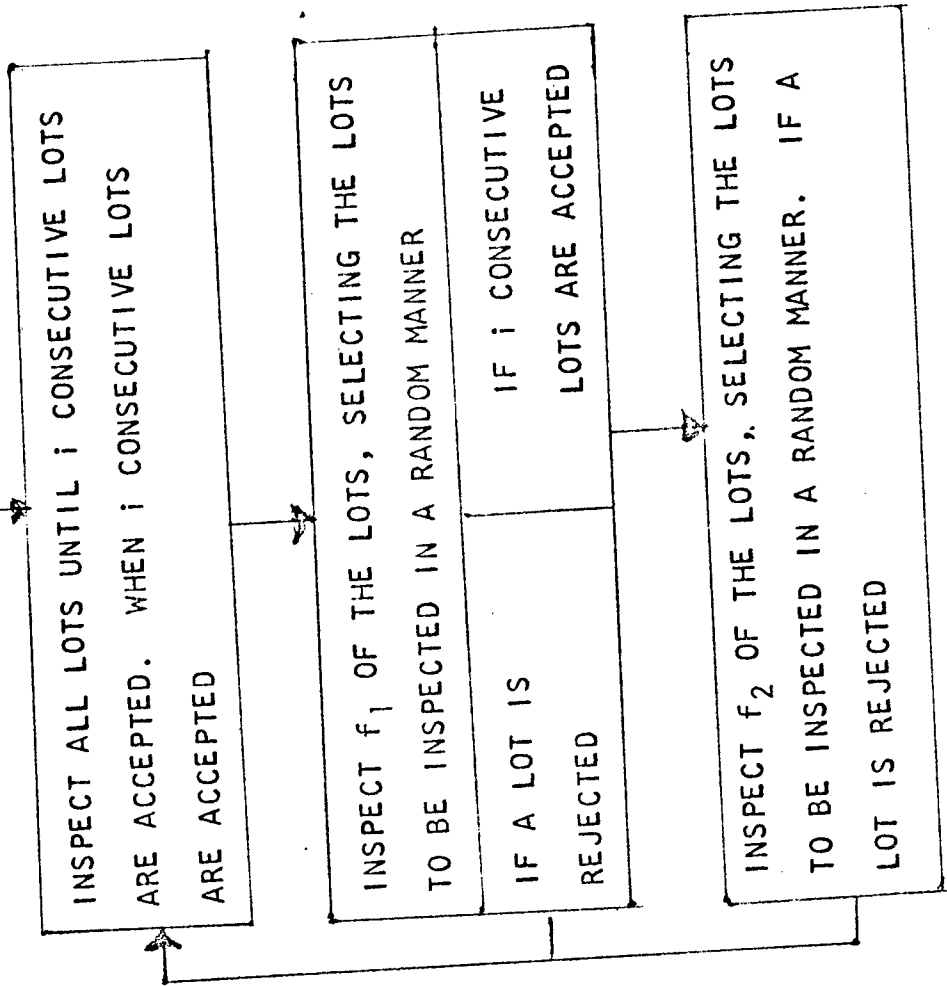
While the Markov chain method permits solution of complex problems, it still involves quite a bit of work. In 1970, after working for several years in the area of plan development and problem solution in continuous sampling plans, the author developed a simplifying algorithm [1]. Although it is described in terms of a continuous sampling plan, it applies also to a skip-lot procedure. The necessary derivations and justifications are provided in [1], so there is no need to go through all of it here. Instead, I'd like to give a short philosophical explanation of what the simplified Markov chain method is about, and a short example of how it works.

For our example, let's use what Perry [10] called the 2L.2 procedure, which he made analogous to a continuous sampling plan investigated by Guthrie and Johns [7], who obtained the plan from a family of plans developed by Derman, Littauer, and Solomon [3]. This is shown on Figure 2.

The rules of the procedure are as follows: Start with normal inspection, inspecting every lot. When  $i$  consecutive lots are accepted on normal inspection, switch to skipping inspection at rate  $f_1$ . If we now have  $i$  consecutive lots accepted, we go to rate  $f_2$ , but if a lot is rejected, we return immediately to normal inspection. While we are at rate  $f_2$ , we return to normal inspection whenever a lot is rejected.

FIGURE 2

START



The next step in the usual Markov chain approach is to set up the transition probability matrix, by considering each lot to be represented by a state in a Markov chain. For example, Perry's transitional probability matrix is shown in Table 1, where

NR denotes lot rejection on normal inspection.

NJ denotes number of consecutively accepted lots during normal inspection is  $j$  ( $j = 1, 2, \dots, i$ ).

SlAj denotes number of consecutively inspected and accepted lots during skipping inspection at rate  $f_1$  is  $j$  ( $j = 1, 2, \dots, i$ ).

SlR denotes lot rejected during skipping inspection at rate  $f_1$ .

SlNj denotes lot skipped during skipping inspection at rate  $f_1$ , and previous number of inspected and accepted lots on skipping inspection at rate  $f_1$  is  $j$  ( $j = 0, 1, \dots, i-1$ ).

S2A denotes lot inspected and accepted during skipping inspection at rate  $f_2$ .

S2R denotes lot rejected during skipping inspection at rate  $f_2$ .

S2N denotes lot skipped during skipping inspection at rate  $f_2$ .

The simplified Markov chain approach restructures the problem by defining what the Markov chain represents. Under the old Markov chain method, each lot is represented by a state in a finite Markov chain. Under the simplified method, we might imagine that we have collected all lots occurring consecutively in any given phase of the procedure in big boxes, where the size of the box is unlimited. The labels on the boxes represent the phases of the procedure. The states of the Markov chain represent the labels on the box. In our example, since we have only three kinds of labels, normal, first skipping level, and second skipping level, we have a Markov chain with only three states. Our concern a little later will be with the expected number of lots in a box with a given label.

TABLE 1  
TRANSITION MATRIX

STATE AT TIME (t-1)	STATE AT TIME t													
	NR	NI	N2...	NI	S1A1	S1A2...	S1A1	S1R	S1N0	S1N1...	S1N(i-1)	S2A	S2N	S2R
NR	Q	P	.	.	.	.	.	.	.	.	.	.	.	.
NI	Q	.	P	.	.	.	.	.	.	.	.	.	.	.
.	.	.	.	.	.	.	.	.	.	.	.	.	.	.
N(i-1)	Q	.	.	P	.	.	.	.	.	.	.	.	.	.
NI	.	.	.	.	f <sub>1</sub> P	.	.	f <sub>1</sub> Q	1-f <sub>1</sub>	.	.	.	.	.
S1A1	.	.	.	.	.	f <sub>1</sub> P	.	f <sub>1</sub> Q	.	1-f <sub>1</sub>	.	.	.	.
.	.	.	.	.	.	.	.	.	.	.	.	.	.	.
S1A(i-1)	.	.	.	.	.	.	f <sub>1</sub> P	f <sub>1</sub> Q	.	1-f <sub>1</sub>	.	.	.	.
S1A1	.	.	.	.	.	.	.	.	.	.	.	f <sub>2</sub> P	1-f <sub>2</sub>	f <sub>2</sub> Q
S1R	Q	P	.	.	.	.	.	.	.	.	.	.	.	.
S1N0	.	.	.	.	f <sub>1</sub> P	.	.	f <sub>1</sub> Q	1-f <sub>1</sub>	.	.	.	.	.
.	.	.	.	.	.	.	.	.	.	.	.	.	.	.
S1N(i-1)	.	.	.	.	.	.	f <sub>1</sub> P	f <sub>1</sub> Q	.	1-f <sub>1</sub>	.	.	.	.
S2A	.	.	.	.	.	.	.	.	.	.	.	f <sub>2</sub> P	1-f <sub>2</sub>	f <sub>2</sub> Q
S2N	.	.	.	.	.	.	.	.	.	.	.	f <sub>2</sub> P	1-f <sub>2</sub>	f <sub>2</sub> Q
S2R	Q	P	.	.	.	.	.	.	.	.	.	.	.	.

Table 2 shows the transition probability matrix using the simplified Markov chain approach.

TABLE 2  
TRANSITION MATRIX FOR SIMPLIFIED MARKOV CHAIN

	N	FSL	SSL
N	-	1*	-
FSL	1 - P <sup>i</sup>	-	P <sup>i</sup>
SSL	1*	-	-

\*For P < 1

The resulting state probability equations are

$$N = (1 - P^i)FSL + SSL \quad (1)$$

$$FSL = N \quad (2)$$

$$SSL = P^i FSL. \quad (3)$$

Solving for each of the state probabilities in terms of one of them, we have

$$N = N \quad (4)$$

$$FSL = N \quad (5)$$

$$SSL = P^i N. \quad (6)$$

Our interest now is in the coefficients in the resulting equation. These are brought over into column one of our working table, Table 3.

TABLE 3  
WORKING TABLE

	<u>1</u> COEF.	<u>2</u> SIMP.	<u>3</u> EX. NO.	<u>4</u> SIMP.	<u>5</u> PROD.
N	1	1	(1-P <sup>i</sup> )/Q P <sup>i</sup>	f <sub>1</sub> f <sub>2</sub> (1-P <sup>i</sup> )	f <sub>1</sub> f <sub>2</sub> (1-P <sup>i</sup> )
FSL	1	1	(1-P <sup>i</sup> )/f <sub>1</sub> Q	f <sub>2</sub> P <sup>i</sup> (1-P <sup>i</sup> )	f <sub>2</sub> P <sup>i</sup> (1-P <sup>i</sup> )
SSL	P <sup>i</sup>	P <sup>i</sup>	1/f <sub>2</sub> Q	f <sub>1</sub> P <sup>i</sup>	f <sub>1</sub> P <sup>2i</sup>

This is our working table needed to complete the solution. Column one lists the coefficients we just mentioned. Column two provides for simplifying column one by clearing denominators or dividing by common factors. Any operation carried out on one element of a column must be carried out on each of the other elements simultaneously. In this case, there is nothing that can be simplified, so column two is the same as column one. Column three contains expressions for the expected number of lots contained in the boxes with the respective labels. Expressions for the various kinds of phases one would expect to encounter are contained in [1]. Column four serves to simplify column three, in the same way that column two is intended to simplify column one. In this case, we see that we can clear the denominator by multiplying each element in column three by  $f_1 f_2 Q P^i$ . Column five is the product of columns two and four.

Let the sum of the column five elements equal D.  
Then

$$N = f_1 f_2 (1-P^i)/D \quad (7)$$

$$FSL = f_2 P^i (1-P^i)/D \quad (8)$$

$$SSL = f_1 P^{2i}/D \quad (9)$$

We are now ready to determine our long-run operating characteristic curve, which is defined in terms of stationary probabilities as

$$P_a = P[N + f_1 FSL + f_2 SSL] + (1-f_1)FSL + (1-f_2)SSL \quad (10)$$

Notice that we are saying that inspected lots are accepted with probability P while all skipped lots are accepted.

Substituting expressions for N, FSL, and SSL and carrying out a few algebraic operations leads to Perry's solution

$$P_a = \frac{f_2 [P^i + f_1 (P-P^i)] + (f_1 - f_2) P^{2i}}{f_2 [P^i + f_1 (1-P^i)] + (f_1 - f_2) P^{2i}} \quad (11)$$



## REFERENCES

1. Brugger, R. M., "A simplification of the Markov chain approach to continuous sampling plan formulation", QEM 21-230-12, Ammunition Procurement and Supply Agency, March 1972.
2. Brugger, R. M., "Responsiveness properties of continuous sampling plans", Proceedings of the Nineteenth Conference on the Design of Experiments in Army Research, Development and Testing, to be published.
3. Derman, C., Littauer, S., and Solomon, H., "Tightened multi-level continuous sampling plans", Annals of Mathematical Statistics, Vol. 28, No. 2, June 1957, pp. 359-404.
4. Dodge, H. F., "A sampling plan for continuous production", Annals of Mathematical Statistics, Vol. 14, No. 3, September 1943, pp. 264-279.
5. Dodge, H. F., "Skip-lot sampling plans", Industrial Quality Control, Vol. 11, No. 5, February 1955, pp. 3-5.
6. Endres, A. E., "The derivation of the operating characteristic curve of a slip-lot sampling plan", Proceedings of the Thirteenth Conference on the Design of Experiments in Army Research, Development and Testing, pp. 31-42.
7. Guthrie D. and Johns, M. V., "Alternative sequences of sampling rates for tightened multi-level continuous sampling plans", Technical Report No. 36, February, 1958, Applied Mathematics and Statistics Laboratory, Stanford University, Stanford, CA.
8. Lieberman, G. J., and Solomon, H., "Multi-level continuous sampling plans", Annals of Mathematical Statistics, Vol. 26, No. 4, December 1955, pp. 686-704.
9. Perry, R. L., "Skip-lot sampling plans", Journal of Quality Technology, Vol. 5, No. 3, July 1973, pp. 123-130.
10. Perry, R. L., "Two-level skip-lot sampling plans - operating characteristic properties", Journal of Quality Technology, Vol. 5, No. 4, October 1973, pp. 160-166.
11. Stine, C. E., "Project SKIP - An idea takes hold", The Army Logistician, Vol. 6, No. 3, May-June 1974, pp. 30-31.

SEMI MARKOV CHAINS APPLIED TO MARKOV CHAIN  
MODELS OF CONTINUOUS SAMPLING PLANS

David L. Arp  
Naval Weapons Center  
China Lake, California

ABSTRACT. A method is presented for overcoming some of the complexities of analyzing time-homogeneous, irreducible, and finite state Markov Chain (MC) models of Continuous Sampling Plans (CSP's), with potential applications to other processes, by constructing from any such MC a unique Semi Markov Chain (SMC). To this end, a class of MC models is defined in terms of four different basic blocks of MC states called phases which are naturally and unambiguously defined by the MC structures considered. For a phase of a given type, a time-of-sojourn probability density function (p.d.f.) is derived for each possible exit. Any phase, together with its p.d.f.'s, that occurs in a MC is then treated as a SMC state. If self-jumps of phases are forbidden, the SMC so constructed induces and is induced by a unique Markov Renewal Process (MRP); otherwise the MRP induces the SMC but not conversely.

This constructive technique, the Z-transform calculus, and Renewal Theory are used to analyze at length, for the Job Shop and Arbitrary Entry cases, the two most common CSP's and the first two moments of the Fraction Inspected functional defined on them. Variations in phase types and/or their p.d.f.'s are considered resulting in, for a given MC, variant SMC's which are in turn studied using the concept of filtration.

For the Arbitrary Entry case, delayed p.d.f.'s are defined by a renewal-theoretical way and by an intuitive constructive way using an initial probability vector which overtly depends on the entire MC model. These two definitions are shown to be equivalent thereby proving the latter, along with certain probability ratios, to be purely phase-type dependent. Using these delayed p.d.f.'s, it is demonstrated that the resulting SMC and MRP are stationary.

Other more complex standard and non-standard plans are also dealt with briefly.

1.0 INTRODUCTION. A prevalent classical treatment of a class of Continuous Sampling Plans (CSP's) has been the study of certain functionals defined on finite-state, ergodic, and time-homogeneous Markov Chain (MC) models which distinguish different types of groupings, called phases, of the states involved -- screening (sc), unlimited sampling (uls), limited sampling (ls), and checking (ck) phases being the usual types [see Refs. 7.4 and 7.5]. These phases are in turn hooked together in various ways and in varying numbers, in accordance with sampling frequency criteria, to generate the plans making up this class. Moreover, time is operational and is discretely measured by "number of production units". Of primary importance in measuring the effectiveness of such a sampling plan is the functional Fraction Inspected which can be defined as follows:

$$FI(N) = 1 - \frac{1}{N} \sum_{j=0}^N \sum_{(SN)} M_{SN}(j)$$

Where

N = number of units (or run number),

$$M_{SN}(j) = \begin{cases} 1 & \text{if } M_{SN}(j) = SN \\ 0, & \text{otherwise} \end{cases}$$

and SN varies over all the non-inspection states of the corresponding MC model. In deriving formulas for the moments of FI(N), only two starting conditions are of practical importance; the Job Shop and the Arbitrary Entry. In the former case, the components of the initial probability vector are 1 for the starting state of a sc phase and zero for all other states and, for the latter case, the components are the steady state or long run probabilities.

To date, only the first moment of this functional has been derived in the Job Shop case for an infinite run and, since the long-run probabilities are also stationary, in the Arbitrary Entry case as well (independent of N). In

an earlier paper by the author [Ref. 7.1], in order to obtain, for the simplest and most heavily used of these plans (CSP-1), the mean and variance of the above functional in the short-run Job Shop case and its variance for the Arbitrary Entry case, advantage was taken of the sparseness and regularity of the transitional matrix of the corresponding model to generate difference equations for the salient transitional probability functions which were in turn solved for by the Z-transform method.

Unfortunately, for plans more complex than CSP-1, this method becomes less feasible because of the increased difficulty in deriving the basic difference equations. This situation arises from the accretion of MC state relationships as the plan complexity increases despite the fact that the transitional matrices still remain relatively sparse. In addition, increasing complexity makes it harder to (1) obtain bounds on the moments of  $FI(N)$ , (2) to study the growth properties of and relationships between the transitional probability functions and quantities derived from them (which is hard even for CSP-1), (3) to obtain closed expressions and asymptotic expansions for these quantities, and (4) to quantitatively analyze structural differences among the various plans. It seems, therefore, that the difficulties enumerated above would, at best, force a piecemeal approach to CSP's in general with each plan having to be laboriously analyzed from scratch. However, in 1971, R. Brugger [Ref. 7.3] presented a unified and simplified scheme of deriving the mean of  $FI(\infty)$  in the Job Shop case and of  $FI(N)$  in the Arbitrary Entry case for sampling plans of this class (with obvious extensions to still more general classes). It is his systematic treatment that stimulated the approach given in the present paper.

In this paper, the drawbacks to using the difference equation, Z-transform approach are partially (and in some respects completely) sidestepped by the introduction of Semi Markov Chain (SMC) models. In these models, each phase is considered to be a SMC state; the time from entrance to and exit from a given phase to another is treated as the time-of-sojourn in that state

until that particular transition first occurs. Furthermore, the probability density functions (p.d.f.'s) of these sojourn times are obtained in essentially two different but equivalent ways; formulas for the first entrance probability functions are derived either from an absorbing MC or an absorbing SMC setup in which the given MC states of a phase are regarded either as transient MC or transient SMC states respectively and in both approaches, the possible exit phases are regarded as absorptive states (all other remaining phases being deleted). Because the original MC model of any plan in this class is time homogeneous, irreducible, and finite, the SMC model constructed from it is also -- a circumstance which eventually leads to a finite system of easily solved, linear convolution equations for the desired probabilities and quantities derived from them.

The SMC method of obtaining the p.d.f.'s for the canonical phases by splitting them into new one-MC-state subphases, obtaining the corresponding p.d.f.'s, and then reassembling the pieces at the end is really just a variation of the basic idea of constructing a SMC from a MC. Elaborating on this observation, similar departures from the prescription "canonical phase  $\leftrightarrow$  SMC state" are also considered to aid in the analysis of CSP's: combining two or more canonical phases into a new (super) phase, splitting a canonical phase into two or more new (sub) phases, and/or altering the p.d.f.'s of the phases by the introduction of self-transitions. Thus the word "canonical" (or "basic") should be considered only as a handy reference term. This added flexibility broadens the applicability of the constructive technique to include MC models in general: for example, weapon-effectiveness and acquisition-of-target models, skip lot sampling procedures [Ref. 7.5], or CSP's with either different types of phases than those considered here or with two or more of the same type which are, however, described by different parametric values. Moreover, as will be seen, the SMC that results from any coalescing of phases is a filtered SMC of the original. Hence, using the variant techniques suggested by the SMC method, we now can associate with or construct from a MC model not just one SMC, but rather a partially ordered set of SMC's with order relation:  $SMC_1 < SMC_2$  iff  $SMC_1$  is a filtration of  $SMC_2$ .

Some troubles do arise in two situations due to the non Markovian nature of a SMC and in a third setting due to the relationship between a Markov Renewal Process (MRP) and a SMC. The first difficulty occurs in the derivation of the second moment of  $FI(N)$ ; the troublesome point is resolved by the introduction of the concept of filtration (in this case, phase segmentation). The second problem lies in the meaning of stationarity for a SMC and arises specifically here in the treatment of the Arbitrary Entry case. This latter complication is overcome by the introduction of delayed p.d.f.'s, which are equivalent to the delayed p.d.f.'s in Markov Renewal Theory. The third difficulty involves the proper handling of self-transitions: a MRP will record such jumps while the induced SMC will not. If a probabilistic interpretation is to be maintained, this snag is handled by treating the MRP as the primary object, the SMC as secondary.

1.1 Notational idiosyncrasies. Throughout the rest of this paper, certain notational idiosyncrasies are observed. (a) In dealing with transfer functions like  $\hat{Q}(z)$  say, many times the explicit argument is deleted especially in complex formulas. (b) Many of the proofs alternate between the convolutional or sequential notation and the equivalent transfer functional one in order to provide some variety; the transfer or "hat" notation greatly predominates however because of greater ease in manipulation. (c) CSP is sometimes used synonymously with MC model, sometimes not; the context makes the usage clear. (d) Since the MC states are, by tradition, symbolized by upper case letters, the phases by lower case ones, a minor inconsistency arises whenever any of the canonical phases are split; for example,  $uls$  can be split into its component MC states SI (Sampling Inspected) and SN (Sampling Noninspected) which in turn can be looked upon as (variant) phases. For simplicity, this "dual" system is retained here; for instance, when necessary, we shall talk about the phase SN rather than the phase  $sn$ .

1.2 Acknowledgements. I would like to thank Mr. Richard M. Brugger specifically for his questions concerning self transitions for the  $sc$  phase. His queries led me to consider this topic not only for the  $sc$  phase but also the  $uls$  phase as well. Also, I would like to thank Mrs. Carmen Ill for the valuable assistance she provided in the preparation of the manuscript.

## 2.0 PRELIMINARY DEFINITIONS AND RESULTS.

2.1 Z-transform. Throughout this paper, the Z-transform method will be used exclusively; it is however formally equivalent to the generating function method, the transformation  $w = 1/z$  being the bridge between the two techniques. Below,  $NN$  is the set of natural numbers and  $RR$  is the set of real numbers.

Definition 1. Given a sequence  $\{a(j)\}$  considered as a function

$$"a: NN \rightarrow RR",$$

its Z-transform is

$$\hat{a}(z) = \sum_{j=0}^{\infty} \frac{a(j)}{z^j} .$$

To retrieve the sequence  $a(\cdot)$ , contour integration is used:

$$a(n) = \frac{1}{2\pi i} \oint_{\Gamma} \hat{a}(z) z^{n-1} dz$$

Where  $\Gamma$  is the path  $|z| = R(a) + \epsilon$ ; in any subsequent use of this formula, the following abbreviation will be used:

$$\frac{1}{2\pi i} \oint_{\Gamma} = \int .$$

In definition 1,  $\hat{a}(z)$  is a function of a complex variable  $z$ , analytic in a neighborhood of infinity; i.e.,  $\hat{a}(z)$  is analytic for  $|z| > R(a)$  whose size, in turn, depends on the growth properties of  $a(j)$  as  $j \rightarrow \infty$ .

We next define two heavily used standard sequences, the operation of convolution between two arbitrary ones, and the Z-transform of these results.

Definition 2. The Dirac sequence at k,

" $\delta_k: \mathbb{N} \rightarrow \{0,1\}$ " for  $k \in \mathbb{N}$ , is defined via:

$$\delta_k(j) = \begin{cases} 1, & \text{for } j=k \\ 0, & \text{otherwise.} \end{cases}$$

Definition 3. The Heaviside sequence at k,

" $H_k: \mathbb{N} \rightarrow \{0,1\}$ " for  $k \in \mathbb{N}$ , is defined via:

$$H_k(j) = \begin{cases} 1, & j > k \\ 0, & \text{otherwise.} \end{cases}$$

Proposition 1.

$$\hat{\delta}_k(z) = \frac{1}{z^k} \text{ and } \hat{H}_k(z) = \left( \frac{1}{z^{k-1}} \right) \left( \frac{1}{z-1} \right), \quad k \in \mathbb{N}.$$

Proof. Clear from the definitions.

Definition 4. Given two sequences  $a(\cdot)$  and  $b(\cdot)$ , their convolution  $a*b(\cdot)$  is a new sequence given by

$$(a*b)(n) = \sum_{k=0}^n a(n-k)b(k).$$

Proposition 2. Letting  $RM = \text{Max}(R(a), R(b))$ ,

$$\widehat{a*b}(z) = \hat{a}(z)\hat{b}(z); \quad \widehat{a+b}(z) = \hat{a}(z)+\hat{b}(z); \text{ and}$$

$$\widehat{ra}(z) = r\hat{a}(z) \text{ for } |z| > RM \text{ where appropriate}$$

and  $r \in \mathbb{R}$ .

Proof. The preceding definitions and the Cauchy product for the multiplication of two power series.

We next state a useful property of the Z-transform.



Theorem 1. (End point property) If  $a(\cdot)$  is a bounded sequence, then  $\hat{a}(z)$  converges at least for  $|z| = R > 1$  and

$$\lim_{z \rightarrow 1} \frac{z-1}{z} \hat{a}(z) = a(\infty).$$

Proof. See reference 7.2, chp. 11.

2.2 Semi Markov Chains. We next define the concept of a SMC. Given a finite set  $S$ , numbered from 1 through  $r$ , an outcome space  $\Omega$  (of sample paths), and a family of random variables  $\{X(t)\}$ ,  $t \in \mathbb{N}$ , from  $\Omega$  to  $S$ , we have

Definition 5.  $X(\cdot)$  is a finite state, time homogeneous Semi Markov Chain iff for each  $i \in S$ , there exists a family of functions from  $\mathbb{N}$  to  $[0,1]$ ,

$$\{Q_{i,j}(t)\}, j \in S_i \subseteq S,$$

such that

1.  $0 \leq Q_{i,j}(t), j \in S_i$
2.  $\sum_j Q_{i,j}(\infty) = 1, j \in S_i$
3.  $P[X(t)=j \mid X(t')=i, 0 \leq t' < t] = Q_{i,j}(t)$
4.  $Q_{i,j}(t', t+t') = Q_{i,j}(0, t) = Q_{i,j}(t)$ .

The following interpretations can be given to the four steps in definition 5. A SMC can be looked upon as a MC in which transitions take place at random times; for  $i \in S$ ,  $\{Q_{i,j}(t)\}$  is just the family of defective p.d.f.'s of the time to transition to some possible exit state; depending on  $i$ , and starting initially from  $i$ ; i.e., the functions are just the time-of-sojourn p.d.f.'s. Step 2. of the definition guarantees that a transition will occur with

probability one. Step 3. is just a more symbolic restatement of the interpretation for the functions  $Q_{i,j}$ , explicitly linking them to  $X(\cdot)$ . Finally, step 4. is the time homogeneity criterion.

In preparation for the next major theorem, we list, for convenience, some abbreviations in definition 6. To emphasize some of the short hand notations, one should note that  $H_0 * a(t) = \sum a(j), j = 1 \text{ to } t$ , and  $(\delta_0 * a)(t) = a(0)$ .

Definition 6.

- a.  $H_0 * Q_{i,k}(t) = A_{i,k}(t)$
- b.  $\sum_k Q_{i,k}(t) = Q_i(t), k \in S_i$
- c.  $\sum_k A_{i,k}(t) = A_i(t), k \in S_i$
- d.  $H_0 * [(q_{i,k}) \delta_0 - Q_{i,k}](t) = J_{i,k}(t)$
- e.  $H_0 * [\delta_0 - Q_i](t) = J_i(t)$ .

Some comments on definition 6 follow. In a.,  $A_{i,k}(t)$  is the (defective) distribution function (d.f.) for the transition  $i \rightarrow k$ .  $Q_i$  in b. or  $A_i$  in c) is the (non defective) p.d.f. or d.f. respectively of a transition from  $i$ . In d.  $J_{i,k}(t)$  is the (defective) d.f. of no transition from  $i$  to  $k$  and finally, summing this quantity over all possible exit states from  $i$ , we get  $J_i$  which is the d.f. of no transition from  $i$ . In the future, for convenience, we let  $Q_{i,k}(t) = 0$  if  $k \notin S_i$  thus eliminating the need for additional notation. Having definition 6, we can now state

Theorem 2. (Backward equations) If we define

$$P_{i,j}(t) = P[X(t)=j \mid X(0) = i],$$

we then have

$$(F.S.) \quad P_{i,j}(t) = \sum_k (Q_{i,k} * P_{k,j})(t) + (\delta_{i,j}) J_i$$

$k \in S, \delta_{i,j}$  is the ordinary Kronecker  $\delta$ .

Proof. Time homogeneity and conditioning on the time of first transition starting from  $i$ ; also see [7.9 and 7.11].

Associated with any SMC is its embedded MC; we define this in

Definition 7. Let  $W_n$  be the time for the  $n^{\text{th}}$  transition; let

$$Y(n) = X(W_n).$$

Then  $Y(\cdot)$  is the Embedded MC associated with  $X(\cdot)$ .

Clearly,

$$[A_{i,j}(+\infty)] = [q_{i,j}]$$

is the transitional matrix for  $Y(\cdot)$ ; it is time homogeneous since  $X(\cdot)$  is.

Letting  $F_{i,k}(t)$  be the first entrance probability of  $i$  into  $k$ , which exists since transitions take place at Markov points or epochs (i.e., the  $W_n$ 's), conditioning on the first entrance, and using the Z-transform, we have

Proposition 3.

$$a. \quad P_{j,j}(t) = F_{j,j} * P_{j,j}(t) + J_j(t).$$

$$a'. \quad \hat{F}_{j,j} = 1 - \frac{\hat{J}_j}{\hat{P}_{j,j}} \quad \text{and} \quad \hat{P}_{j,j} = \frac{\hat{J}_j}{1 - \hat{F}_{j,j}}$$

$$b. \quad P_{j,k}(t) = F_{j,k} * P_{k,k}(t).$$

$$b'. \quad \hat{F}_{j,k} = \frac{\hat{P}_{j,k}}{\hat{P}_{k,k}} \quad \text{and} \quad \hat{P}_{j,k} = \hat{F}_{j,k} \hat{P}_{k,k}.$$

Letting  $W_n(k)$  be the time of occurrence (waiting time) of the  $n^{\text{th}}$  entrance into  $k$  by  $X(\cdot)$ , we have

Definition 3.

$$N_k(t) = \text{Max} \{n \mid W_n(k) \leq t\}$$

$$E_j[N_k(t)] = E[N_k(t) \mid X(0)=j] = R_{j,k}(t)$$

$$N(t) = \sum_k N_k(t), k \in S$$

$$\underline{N}(t) = (N_k(t)), k \in S.$$

Proposition 4.

$$P_{k,k}(t) = R_{k,k} * (\delta_0 - Q_k)(t)$$

$$P_{j,k}(t) = R_{j,k} * (\delta_0 - Q_k)(t).$$

Proof.

$$\begin{aligned} \text{a. } \sum_{n=0}^{\infty} H_0 * F_{k,k}^{(n)}(t) &= 1 + \sum_{n=1}^{\infty} P_k[W_n(k) \leq t] \\ &= 1 + \sum_{n=1}^{\infty} P_k[N_k(t) \geq n] \\ &= 1 + \sum_{m=1}^{\infty} m P_k[N_k(t) = m] \\ &= E_k[N_k(t)] \end{aligned}$$

b.  $\bullet \bullet$  taking Z-transforms, we have

$$\frac{\hat{H}_0}{1 - \hat{F}_{k,k}} = \hat{R}_{k,k}$$

Similarly, we also have

$$R_{jk} = F_{jk} * R_{kk} \quad \text{or} \quad \hat{R}_{jk} = \hat{F}_{jk} \hat{R}_{kk}.$$

c. From b. and Prop 3a' and 3b',

$$\begin{aligned} \hat{P}_{kk} &= \frac{\hat{H}_0 (1 - \hat{Q}_k)}{1 - \hat{F}_{kk}} \\ &= \hat{R}_{kk} (1 - \hat{Q}_k) \end{aligned}$$

and

$$\begin{aligned} \hat{P}_{jk} &= \hat{F}_{jk} \hat{P}_{kk} \\ &= \hat{F}_{jk} \hat{R}_{kk} (1 - \hat{Q}_k) \\ &= \hat{R}_{jk} (1 - \hat{Q}_k). \end{aligned}$$

As in a finite MC, we can define recurrent state, communication of states, irreducibility, and periodicity. With these topics in mind, we state

**Theorem 3.** A (finite) SMC is irreducible iff its embedded MC is. A SMC is aperiodic iff there exists  $j - S_i$  such that  $\text{support } (Q_{ij}) \subseteq \{\lambda t\}$ ,  $t = 1$  to  $\infty$  provided that the SMC is irreducible.

**Proof.** (a) First statement see [Ref 7.6, Chp 5],  
(b) Second statement see [Ref 7.7, Chp 2].

The proofs are straight forward but lengthy.

If  $i \notin S_i$  (i.e.,  $Q_i, i = 0$  for all  $i$ ) for all  $i$ , then an irreducible SMC induces a uniquely defined MRP and conversely. The MRP can be taken to be  $\{(Y_n, \tau), \tau$  is the time spent in  $Y_n$  since the last transition} [Ref 7.6, Chp 7]; in older terminology [Refs 7.11, 7.12],  $N(t)$ , definition 8, is defined as the associated MRP since  $\{(K, W_n(K)), K \in S\}$  can be looked upon as a multiple markov renewal process. Conversely, the MRP induces the SMC via:  $X(t) = Y_{N(t)}$ .

Closing the section, we give the basic theorem on irreducible SMC's.

Theorem 4. If  $\mu_s$  is the long-run mean time-of-sojourn in state  $s$ , then, given that the SMC is irreducible and finite with  $\underline{e} = (e_1, \dots, e_\gamma)$  as the corresponding eigen vector of the embedded MC matrix with eigen value one, we have

$$\begin{aligned} \text{a. } \lim_{t \rightarrow \infty} P_{i,j}(t) &= P_j(\infty) \\ &= \alpha_j \\ &= \frac{e_j \mu_j}{\sum_s e_s \mu_s} \end{aligned}$$

$$\text{b. } \lim_{z \rightarrow 1} \left( \frac{z-1}{z} \right) \hat{P}_{i,j}(z) = P_j(\infty)$$

c. An ergodic theorem holds:

if  $F$  is a functional, then

$$\frac{1}{N} \sum_{t=0}^N F(X(t)) \rightarrow E_{\underline{\alpha}} [F] \quad [\text{a.e.}],$$

where

$$\begin{aligned} E_{\underline{\alpha}} [F] &= \sum_s F(s) P_s(\infty) \\ &= \sum_s F(s) \alpha_s. \end{aligned}$$

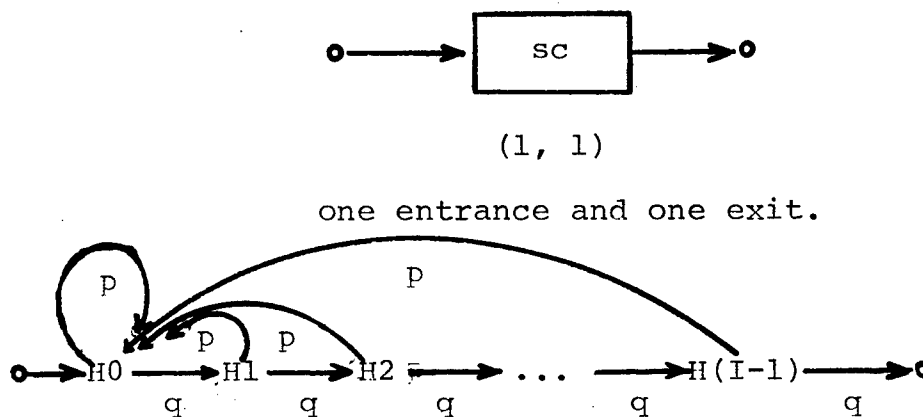
Proof. b. is just the end-pt. property of the Z-transform. a. and c. follow from some straight-forward renewal-theoretical arguments found in [Ref 7.6, Chps 7, 8].

2.3 Sampling Plan Phases. In the following descriptions, the box diagram for each phase is given first followed by the MC description; in passing from the former to the latter, the assumption of a constant probability of defective,  $p$ , is assumed. Furthermore, practically speaking, upon finding a defective, one either discards it or, less realistically, replaces it with a non-defective unit. In Figures 1 through 4,  $q = 1-p$ ,  $f =$  sampling frequency,  $v = 1-f$ , and the transitional probabilities are written beside the corresponding arrows.

Upon entering the screening phase (abbr. sc), inspect the production units at 100% until  $I$  consecutive units are defect free; then exit.

Figure 1

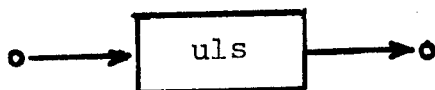
MC Model of Sampling Phase.



Upon entering the unlimited sampling phase (abbr. uls), sample at random with frequency  $f$  until a defect is found (during inspection); then exit.

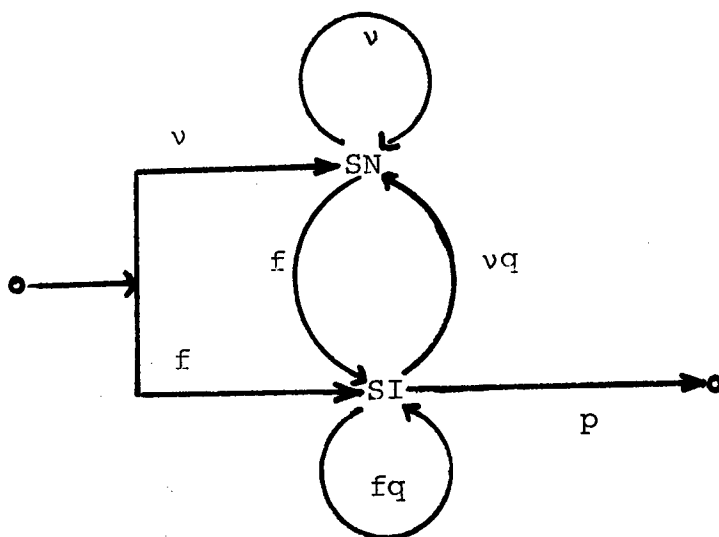
Figure 2

MC Model of Unlimited Sampling Phase.



(1, 1)

one entrance and one exit.



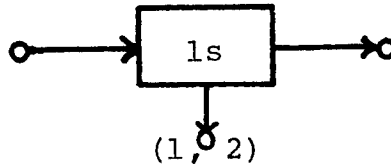
SN = Noninspection State  
 SI = Inspection State

Upon entering a limited sampling phase (abbr. ls) sample at frequency  $f$  until, condition 1,  $k$  units are sequentially found to be defect free or, condition 2, a defect is found before condition 1 is satisfied; then exit to the condition-dependent next phase.

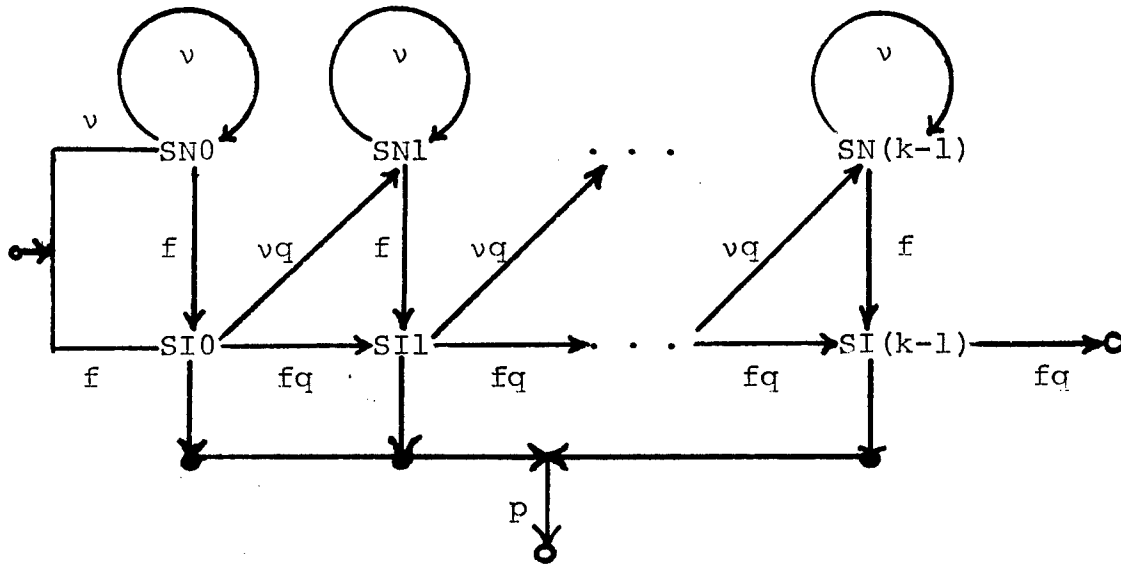


Figure 3

MC Model of Unlimited Sampling Phase.



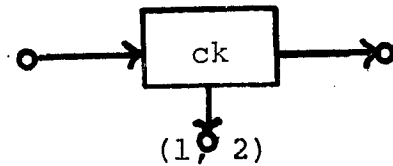
one entrance and two exits



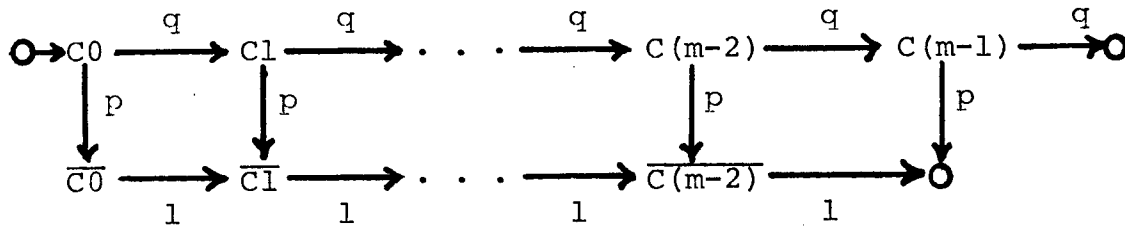
Upon entering the checking phase (abbr. ck) inspect at 100% the next  $m$  units discarding (or replacing) all defective units found; if the  $m$  units are all defect free exit one way or another different way if one or more defects are found.

Figure 4

MC Model of Checking Phase.

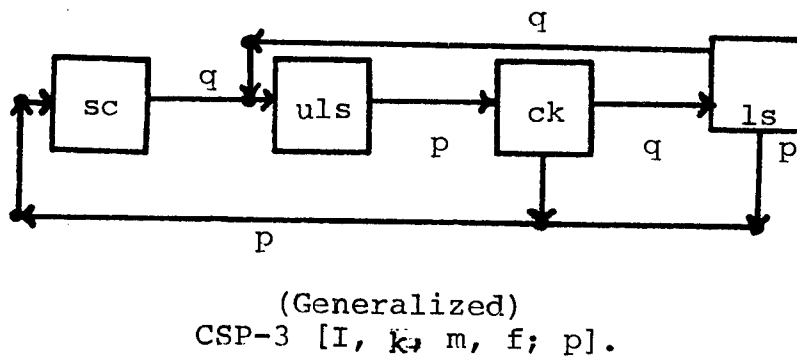
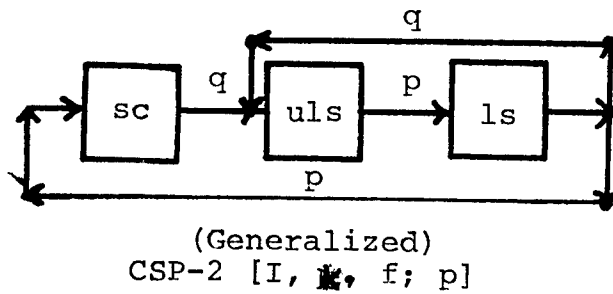
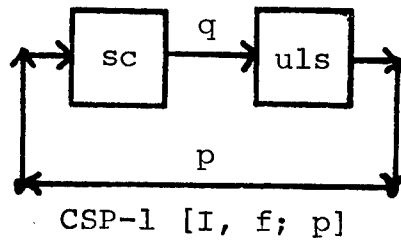


one entrance and two exits.



2.4 Sampling Plans Having defined the sampling phases, it is now an easy matter to describe the two most practical ones, CSP-1 and generalized CSP-2, as well as one which contains all four phases -- generalized CSP-3. The diagrams in Figure 5 are self-explanatory; also, as indicated by the diagrams, the terms CSP and MC model will be used interchangeably unless otherwise stated; the use of the word "generalized" is necessitated by standard usage which requires  $k = 1$  for the 1s phase and  $m = 4$  for the ck phase.

Figure 5  
Sampling Plans.



### 3.0 SAMPLING PLAN PHASES.

3.1 Phases as SMC states. In Theorems one through four below, two essentially different but equivalent methods of proof are used: the MC method and the SMC method. Before launching into a description of these two approaches, we make

Definition 1. A phase is completely ordered iff its states are well-ordered by the phase regime from entrance to exit; it is quasi ordered iff its states are totally ordered by the phase regime from entrance to exit.

In the MC method, for a given phase, an absorbing MC is constructed whose transient states or absorptive states correspond to the phase MC states or exit phases respectively. Using an initial probability vector whose transient components are equal to the individual phase MC state entrance probabilities conditioned by the event of initial phase entrance, the formulas for the first entrance probability functions into the various absorptive states are then derived. Specifically, for a given absorptive state, the first entrance p.d.f. into this state starting from each of the transient states is obtained; then a weighted sum of these functions, each weighed by its initial entrance probability, is taken. The result is the desired p.d.f. for this particular exit phase.

In the SMC method, a given phase is broken up into its constituent MC states by treating any state with self-transitions or no self-transitions as a non-degenerate or degenerate MC (noncanonical) phase respectively. Proceeding according to the MC method, the appropriate p.d.f.'s for each of these (noncanonical) MC phases are then obtained thereby constructing from each such state a "mini" absorbing SMC whose absorptive SMC states are equal in number to the possible exit MC states -- exclusive of the state itself (i.e., no self-transitions are allowed in the SMC). These "mini" absorptive SMC's are then amalgamated into a composite absorbing SMC whose transient states are now the corresponding "mini" transient SMC states and whose absorptive states are, once again, the relevant exit phases. Finally, since a first entrance occurs at an epoch in a SMC, one can proceed to mimic the MC method to derive the first entrance

probabilities. In particular, for a canonical MC phase which is either completely ordered or can be subdivided into subphases which are (e.g., the 1s phase), this method can proceed inductively -- the absorbing state or subphase at step  $h$  being the  $(h + 1)^{\text{st}}$  state or subphase respectively.

Thus, in the end, with either method, we have constructed from a given phase an absorbing SMC with one transient state and absorptive states equal in number to the possible exit phases. Moreover, though the setup given in Chapter two for an absorbing SMC can be formally used for the amalgamation in the SMC method, the proofs below which use this method will be given more constructively and, hopefully, more intuitively. Nonetheless, the absorbing SMC apparatus will always lie in the background. Furthermore, outside of the context of any irreducible SMC, we shall hereafter refer to a phase with its p.d.f.'s either as a potential SMC state, for eventual inclusion in a CSP (irreducible SMC) or as a transient SMC state in the constructive sense of the SMC method; both viewpoints are mathematically equivalent, the nuances different.

In Theorems one through four below,  $A(\cdot)$  will always stand for an absorptive state; for instance, if a phase has only one possible exit, the symbol "A" alone will be used; if two or more exits are possible, the symbols " $A_1$ ", " $A_2$ ", ..., or " $A(1)$ ", " $A(2)$ ", ... will then be used.

Theorem 1. The screening phase is a potential SMC state with p.d.f. given as:

$$\hat{Q}_{\text{sc},A}(z) = \frac{q^I(z-q)}{z^I(z-1)+\gamma}, \quad \gamma = pq^I.$$

Proof. (MC method)

a. Absorbing MC is given by:

	H0	H1	H2	H3	---	H(I-1)	A
H0	p	q	0	0	---	0	0
H1	p	0	q	0	---	0	0
H2	p	0	0	q	---	0	0
-							
-							
-							
H(I-1)	p	0	0	0	---	0	q
A	0	0	0	0	---	0	1

b. Initial probability vector =  $(1, 0, 0, \dots, 0)$ .

c. From the Chapman-Kolmogorov (C-K) equations, we get, from a. and b., the following system (letting  $H_j = j$ ):

$$P_{j,A}^n = pP_{0,A}^{n-1} + qP_{j+1,A}^{n-1}, \quad 0 \leq j < I-1$$

and

$$P_{I-1,A}^n = pP_{0,A}^{n-1} + qH_1$$

since

$$P_{A,A}^k = P_{A,A}^{k-1} + \delta_0(k) \implies$$

$$P_{A,A}^k = H_0(k).$$

d. Because of b., we want to obtain

$$(1) f_{0,A}^n$$

which is just  $Q_{sc,A}(n)$ .

e. But

$$P_{0,A}^n = (f_{0,A} * P_{A,A})^n$$

$$\hat{P}_{0,A} = \hat{f}_{0,A} \cdot \hat{P}_{A,A}$$

$$= \hat{f}_{0,A} \cdot \hat{H}_0.$$

$$\text{Thus, } \hat{f}_{0,A} = (\hat{H}_0)^{-1} \hat{P}_{0,A}.$$

f. From c. we obtain by substitution:

$$P_{0,A}^n = \sum_{j=0}^{I-1} (pq^j) P_{0,A}^{n-(j+1)} + q^I P_{A,A}^{n-I}$$

or

$$\hat{P}_{0,A} = \sum_{j=0}^{I-1} (pq^j) \frac{\hat{P}_{0,A}}{z^{j+1}} + q^I \frac{\hat{H}_0}{z^I}$$

Simplifying and using geometric series summation, we finally have

$$\hat{P}_{0,A} = \hat{H}_0 \left( \frac{q^I (z-q)}{z^I (z-1) + \gamma} \right) .$$

g. Thus from f., e., and d., we have

$$\hat{Q}_{sc,A}(z) = \frac{q^I (z-q)}{z^I (z-1) + \gamma} .$$

Second Proof. (SMC-method).

a'. Since the sc phase is completely ordered, we can proceed by induction. For  $I = 1$ ,

$$\begin{aligned} \text{HO} \xrightarrow{q} A \text{ yields } \hat{Q}_{0,A} &= q/(z-p) \\ &= q(z-q)/(z-p)(z-q) \\ &= \frac{q(z-q)}{z(z-1) + \gamma_1} . \end{aligned}$$

$$b'. \quad \begin{array}{c} \text{p} \\ \downarrow \quad \uparrow \\ \text{scj} \xrightarrow{1} \text{H}(j+1) \xrightarrow{q} A \end{array}$$

$$\hat{Q}_{scj,A(j+1)}(z) = \frac{q^j (z-q)}{z(z-1) + \gamma_j} , \quad \gamma_j = pq^j$$

by induction.

$$\hat{Q}_{j+1,A(scj)}(z) = \frac{p}{z}$$

$$\hat{Q}_{j+1,A}(z) = \frac{q}{z}, \text{ where } (j+1) = H(j+1).$$

c'. Amalgamate (j+1) and scj.

$$\begin{aligned} \text{Thus } \hat{Q}_{scj,A} &= \left\{ \sum_{n=0}^{\infty} (\hat{Q}_{scj,(j+1)} \hat{Q}_{(j+1),scj})^n \right\} \hat{Q}_{scj(j+1)} \hat{Q}_{(j+1),A} \\ &= \frac{\hat{Q}_{scj,(j+1)} \hat{Q}_{(j+1),A}}{1 - \hat{Q}_{scj,(j+1)} \hat{Q}_{(j+1),scj}} \\ &= \frac{q^{j+1} (z-q)}{z^{j+1} (z-1) pq^j z - pq^j z + pq^{j+1}} \\ &= \frac{q^{j+1} (z-q)}{z^{j+1} (z-1) + \gamma_{j+1}}. \end{aligned}$$

Third Proof. (SMC method - no induction) This third proof is given to further elucidate the SMC method.

a". Mini states:  $\{j\}_{j=0}^{I-1}$ ; all are degenerate except for 0. Working with the corresponding mini-absorptive SMC's, we have

$$\hat{Q}_{0,A(1)}(z) = \frac{q}{z-p}$$

$$\left. \begin{aligned} \hat{Q}_{j,A(j+1)}(z) &= \frac{q}{z} \\ \hat{Q}_{j,A(0)}(z) &= \frac{p}{z} \end{aligned} \right\} 0 < j \leq (I-1)$$

where  $A(I) = A$ .



b". Upon amalgamation, we have an absorbing SMC with I transient states

$$\{(j; \hat{Q}_{j,j+1}(z), \hat{Q}_{j,0}(z))\}_{j=1}^{I-2},$$

$$\{(0; \hat{Q}_{0,1}(z)), (I-1; \hat{Q}_{(I-1),A}(z), \hat{Q}_{(I-1),0}(z))\},$$

and one absorbing state (A;  $\hat{Q}_{AA}(z)$ ) where  $\hat{Q}_{AA}(z) = \hat{H}_0(z)$ .

c". Given the (assembled) absorbing SMC in b" we have

$$\sum_{j=0}^{I-1} (\delta_{0,j}) \hat{F}_{j,A}(z) = (1) \hat{F}_{0,A}(z) = \hat{Q}_{SC,A}(z).$$

Theorem 2. The unlimited sampling phase is a potential SMC state with p.d.f. given by

$$\hat{Q}_{uls,A}(z) = \frac{\delta}{z-\beta},$$

where  $\delta$  (unadorned) = fp and  $\beta = 1-\delta$ .

First Proof. (MC method)

a. The absorbing MC is given by

	SN	SI	A
SN	v	f	0
SI	vq	fq	p
A	0	0	1

b. Initial probability vector = (v, f, 0).

c. Again from the C-K eqs. and a., we have:

$$P_{SN,A}^n = vP_{SN,A}^{n-1} + fP_{SI,A}^{n-1}$$

$$P_{SI,A}^n = vqP_{SN,A}^{n-1} + fqP_{SI,A}^{n-1} + pP_{A,A}^{n-1}$$

which implies

$$\hat{P}_{SN,A} = \left(\frac{f}{z-u}\right) \hat{P}_{SI,A}$$

$$\hat{P}_{SI,A} = \frac{uq}{z-fq} \hat{P}_{SN,A} + \frac{p}{z-fq} \hat{H}_0.$$

Since  $\hat{P}_{SN,A} = \hat{f}_{SN,A} \hat{H}_0$

and  $\hat{P}_{SI,A} = \hat{f}_{SI,A} \hat{H}_0$

we have upon simplifying:

$$\hat{f}_{SN,A} = \frac{\delta}{z(z-\beta)} \text{ and } \hat{f}_{SI,A} = \frac{p(z-u)}{z(z-\beta)}.$$

d. From b., we want to obtain

$$(u) f_{SN,A}^n + (f) f_{SI,A}^n = Q_{uls,A}(n).$$

e. Transforming d. and using the last two formulas in c., we have

$$u \left(\frac{\delta}{z(z-\beta)}\right) + f \left(\frac{p(z-u)}{z(z-\beta)}\right) = \frac{\delta}{z-\beta}.$$

f. Thus  $\hat{Q}_{uls,A}(z) = \frac{\delta}{z-\beta}$  from e. and d.

Second Proof. (SMC method)

a'.  $\hat{Q}_{SN,A}(SI)(z) = \frac{f}{z-u}$

$$\hat{Q}_{SI,A}(SN)(z) = \frac{uq}{z-fq}$$

$$\hat{Q}_{SI,A}(z) = \frac{p}{z-fq}$$

Thus we have two non-degenerate mini SMC states and two mini absorbing SMC's with the following embedded MC's:

$$\begin{array}{rcc}
 & & \begin{array}{cc} \text{SN} & \text{A(SI)} \end{array} \\
 \text{SMC(SN):} & \begin{array}{cc} \text{SN} & \\ \text{A(SI)} & \end{array} & \begin{bmatrix} 0 & 1 \\ 0 & 1 \end{bmatrix} \\
 \\
 & & \begin{array}{ccc} \text{SI} & \text{A(SN)} & \text{A} \end{array} \\
 \text{SMC(SI):} & \begin{array}{ccc} \text{SI} & \\ \text{A(SN)} & \\ \text{A} & \end{array} & \begin{bmatrix} 0 & uq/(1-fq) & p/(1-fq) \\ 0 & 1 & 0 \\ 0 & 0 & 1 \end{bmatrix}
 \end{array}$$

b'. Now once again assemble the two mini absorbing SMC's into one aggregate absorbing SMC. The result is an absorbing SMC with two transient states (SN;  $\hat{Q}_{SN,SI}(z)$ ) and (SI;  $\hat{Q}_{SI,SN}(z)$ ,  $\hat{Q}_{SI,A}(z)$ ); one absorptive state (A;  $\hat{Q}_{A,A}(z)$ ); and an embedded MC given by

$$\begin{array}{rcc}
 & \text{SI} & \text{SN} & \text{A} \\
 \text{SI} & \begin{bmatrix} 0 & uq/(1-fq) & p/(1-fq) \\ 1 & 0 & 0 \\ 0 & 0 & 1 \end{bmatrix} \\
 \text{SN} & & & \\
 \text{A} & & & 
 \end{array}$$

c'. Hence, we now want:

$$(u)\hat{F}_{SN,A}(z) + (f)\hat{F}_{SI,A}(z) = \hat{Q}_{uls,A}(z)$$

by d. We can write down expressions for the  $\hat{F}$ 's directly:

$$\hat{F}_{SN,A} = \hat{Q}_{SN,SI} \left\{ \sum_{n=0}^{\infty} (\hat{Q}_{SI,SN} \hat{Q}_{SN,SI})^n \right\} \hat{Q}_{SI,A} = \frac{\hat{Q}_{SN,SI} \hat{Q}_{SI,A}}{1 - \hat{Q}_{SI,SN} \hat{Q}_{SN,SI}}$$

$$\hat{F}_{SI,A} = \left\{ \sum_{n=0}^{\infty} (\hat{Q}_{SI,SN} \hat{Q}_{SN,SI})^n \right\} \hat{Q}_{SI,A}$$

$$= \frac{\hat{Q}_{SI,A}}{1 - \hat{Q}_{SI,SN} \hat{Q}_{SN,SI}}$$

d'. From c'. and simplifying,

$$\hat{Q}_{uls,A}(z) = \frac{(v \hat{Q}_{SN,SI} + f) \hat{Q}_{SI,A}}{1 - \hat{Q}_{SN,SI} \hat{Q}_{SI,SN}}$$

$$= \frac{\delta}{z - \beta} .$$

Theorem 3. The limited sampling phase is a potential SMC state with p.d.f.'s given by:

$$\hat{Q}_{ls,A(1)}(z) = \left( \frac{\delta}{z - \beta} \right) \left( 1 - \left( \frac{fq}{z - v} \right)^k \right)$$

$$\hat{Q}_{ls,A(2)}(z) = \left( \frac{fq}{z - v} \right)^k .$$

First Proof. (MC method)

a. Ordering the states of ls as:  $SN_0, SI_0, \dots, SN_{k-1}, SI_{k-1}, A_1,$  and  $A_2$ ; we have an initial probability vector  $\underline{v} = (v, f, 0, 0, \dots)$ ; i.e.,  $v_{SN_0} = v$  and  $v_{SI_0} = f$ ; the matrix corresponding to the absorbing MC can be easily written down if one desires.

b. For convenience, we combine  $SN_0$  and  $SI_0$  into  $SN_0 \vee SI_0 = S$ . Then, using the C-K equations again, we have

$$P_{S,A(2)}^n = q P_{S,SI(k-1)}^{n-1} + P_{S,A(2)}^{n-1}$$

$$P_{S,SI(k-j)}^n = (fq)P_{S,SI(k-(j+1))}^{n-1} + (f)P_{S,SN(k-j)}^{n-1}$$

$$(1 \leq j \leq k-1)$$

$$P_{S,SN(k-j)}^n = (vq)P_{S,SI(k-(j+1))}^{n-1} + (v)P_{S,SN(k-j)}^{n-1}$$

$$P_{S,SN0}^n = vP_{S,SN0}^{n-1} + (v)\delta_0(n)$$

$$P_{S,SI0}^n = fP_{S,SN0}^{n-1} + (f)\delta_0(n) .$$

c. Letting  $a = \hat{P}_{S,A(2)}$ ,  $b_j = \hat{P}_{S,SIj}$ , and  $c_j = \hat{P}_{S,SNj}$ , then, using the Z-transform in b. and simplifying yields:

$$a = \left(\frac{q}{z-1}\right)b_{k-1}$$

$$(1 \leq j \leq k-1) \begin{cases} c_{k-j} = \left(\frac{qv}{z-v}\right)b_{k-(j+1)} \\ b_{k-j} = \left(\frac{fq}{z-v}\right)b_{k-(j+1)} \end{cases}$$

$$\therefore b_j = \left(\frac{fq}{z-v}\right)^j b_0 \text{ for } 1 \leq j \leq k-1$$

$$\therefore a = \left(\frac{q}{z-1}\right)\left(\frac{fq}{z-v}\right)^{k-1} b_0$$

$$b_0 = \frac{fz}{z-v} .$$

$$\therefore a = \hat{H}_0 \left(\frac{fq}{z-v}\right)^k ; \text{ using a., } \hat{Q}_{1s,A(2)}(z) = \left(\frac{fq}{z-v}\right)^k .$$

For exit to  $A(1)$ , we have:

$$P_{S,A(1)}^n = p \sum_{j=0}^{k-1} P_{S,SIj}^{n-1} + P_{S,A(1)}^{n-1} P_{A(1),A(1)}$$

which implies

$$\hat{P}_{S,A(1)} = \frac{pb_0(z)}{(z-1)} \left(1 - \left(\frac{fq}{z-u}\right)^k\right) \frac{(z-u)}{(z-\beta)}$$

Again using a. and multiplying through by  $(\hat{H}_0)^{-1}$ , we have;

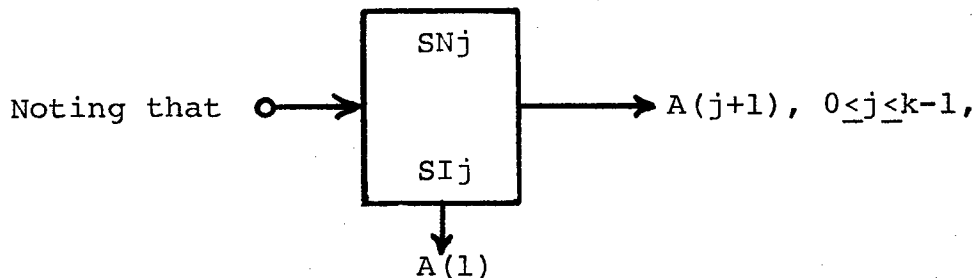
$$\hat{Q}_{1s,A(1)}(z) = \left(\frac{\delta}{z-\beta}\right) \left(1 - \left(\frac{fq}{z-u}\right)^k\right).$$

Second Proof. (SMC method)

$(j+1)$ , for  $0 \leq j \leq k-2$

a'. Let  $A(j+1) =$

$A(2)$ , for  $j = k-1$



are all structurally equivalent, in contrast to the sc phase where  $H_0$  differed from  $H_j$ ,  $0 < j \leq I-1$ , we could use the inductive method applied to 2-state subphases; however, it is easier to use the SMC method directly applied to 2-state phases thereby skipping one logical step in the amalgamation procedure.

b'. For given  $k \geq 1$ , we have

$$\hat{Q}_{SNj,SIj} = f/(z-u)$$

$$\hat{Q}_{SIj,A(j+1)} = q/z$$

$$\hat{Q}_{SIj,A(1)} = p/z \quad (0 \leq j \leq k-1).$$

Therefore for subphase  $j$ , we have

$$\begin{aligned}\hat{Q}_{j,A(j+1)} &= v\hat{Q}_{SNj,SIj}\hat{Q}_{SIj,A(j+1)} + f\hat{Q}_{SIj,A(j+1)} \\ &= fq/(z-v)\end{aligned}$$

$$\begin{aligned}\hat{Q}_{j,A(1)} &= (v)\hat{Q}_{SNj,SIj}\hat{Q}_{SIj,A(1)} + (f)\hat{Q}_{SIj,A(1)} \\ &= fp/(z-v)\end{aligned}$$

c'. Hence we obtain mini absorbing SMC's which have one transient SMC state (two-MC-state) and two absorbing states for each  $j$ . Amalgamating as before, we get  $k$  transient states

$$\{(j; \hat{Q}_{j,j+1}, \hat{Q}_{j,A(1)})\} \bigcup_{j=0}^{k-2} \{(k-1; \hat{Q}_{(k-1),A(2)}, \hat{Q}_{(k-1),A(1)})\}$$

and two absorptive states  $A(1)$  and  $A(2)$ . Its embedded MC is:

	0	1	2	---	(k-1)	A(1)	A(2)
0	0	q	0	---	0	p	0
1	0	0	q	---	0	p	0
-							
-							
(k-1)	0	0	0	---	0	p	q
A(1)	0	0	0	---	0	1	0
A(2)	0	0	0	---	0	0	1

d'. The initial probability vector is now =  $(1, 0, \dots, 0)$ . Thus we now want

$$(1)(\hat{F}_{0,A(1)}) = \hat{Q}_{1s,A(1)}$$

and

$$(1)(\hat{F}_{0,A(2)}) = \hat{Q}_{1s,A(2)}$$

e'. Once again using a constructive derivation, we have

$$\begin{aligned}\hat{F}_{0,A(2)} &= (\hat{Q}_{0,1}) (\hat{Q}_{1,2}) \cdots (\hat{Q}_{(k-1),A(2)}) \\ &= \prod_k \left(\frac{fq}{z-v}\right) \\ &= \left(\frac{fq}{z-v}\right)^k,\end{aligned}$$

and

$$\begin{aligned}\hat{F}_{0,A(1)} &= (\hat{Q}_{0,A(1)}) + (\hat{Q}_{0,1}) (\hat{Q}_{1,A(1)}) + \cdots + \\ &\quad (\hat{Q}_{0,1}) (\hat{Q}_{1,2}) \cdots (\hat{Q}_{k-1,A(1)}) \\ &= \frac{fp}{(z-v)} \left\{ \sum_{j=0}^{k-1} \left(\frac{fq}{z-v}\right)^j \right\} \\ &= \frac{fp}{(z-v)} \left\{ \frac{1 - \left(\frac{fq}{z-v}\right)^k}{1 - \frac{fq}{z-v}} \right\} (z-v) \\ &= \left(\frac{\delta}{z-\beta}\right) \left(1 - \left(\frac{fq}{z-v}\right)^k\right).\end{aligned}$$

Theorem 4. The checking phase is a potential SMC state with p.d.f.'s given by

$$\begin{aligned}\hat{Q}_{ck,A(2)}(z) &= (q/z)^m \\ \hat{Q}_{ck,A(1)}(z) &= (1-q^m)/(z^m).\end{aligned}$$

First Proof. (MC proof)

a. The absorbing MC transitional matrix is easy to write out from Figure 2.

b. Ordering the states  $C_0, C_1, \dots, \bar{C}_0, \dots, A_1, A_2,$  we have  $v = (1, 0, 0, \dots, 0)$  as the initial probability vector.



c. Proceeding as before, we have

$$P_{C0,A(2)}^n = P_{C0,A(2)}^{n-1} P_{A(2),A(2)} + \delta_m(n) q^m$$

$$P_{C0,A(1)}^n = P_{C0,A(1)}^{n-1} P_{A(1),A(1)} + \delta_m(n) (1-q^m) .$$

d. Z-transforming c. and solving we obtain the result.

Second Proof. (SMC method)

a'. Since we neither have a possible re-entry to an initial state at any step nor a natural segmenting of ck into  $(c_j, \overline{c_j})$ , we use the SMC method directly.

b'. The functions

$$(0 \leq j \leq m-1) \begin{cases} \hat{Q}_{c_j, A(j+1)}(z) = \frac{q}{z} \\ \hat{Q}_{c_j, \overline{A(j+1)}}(z) = \frac{p}{z} \end{cases} ,$$

where  $\overline{A(m-1)} = A(1)$  and  $A(m-1) = A(2)$ , and

$$(0 \leq j \leq m-2) \quad \hat{Q}_{\overline{c_j}, \overline{A(j+1)}}(z) = \frac{1}{z} ,$$

where  $\overline{A(m-1)} = A(1)$  again, make up the pieces to be assembled in the usual way.

c'. We want  $(1)\hat{F}_{C0,A(1)}$  and  $(1)\hat{F}_{C0,A(2)}$ . Letting  $c_j = j$  and  $\overline{c_j} = \overline{j}$ , we have

$$\hat{F}_{0,A(2)} = (\hat{Q}_{0,1}) (\hat{Q}_{1,2}) \dots (\hat{Q}_{(m-1),A(2)}) = \left(\frac{q}{z}\right)^m$$

$$\begin{aligned} \hat{F}_{0,A(1)} &= (\hat{Q}_{0,\overline{0}}) (\hat{Q}_{\overline{0},\overline{1}}) \dots (\hat{Q}_{\overline{m-2},A(1)}) \\ &\quad + (\hat{Q}_{0,1}) (\hat{Q}_{\overline{1},\overline{1}}) \dots (\hat{Q}_{\overline{m-2},A(1)}) \\ &\quad + \dots \\ &\quad + (\hat{Q}_{0,1}) (\hat{Q}_{\overline{1},2}) \dots (\hat{Q}_{\overline{m-1},A(1)}) \end{aligned}$$

$$= \frac{p}{z^m} \left( \sum_{j=0}^{m-1} q^j \right)$$

$$= \frac{1-q^m}{z^m} .$$

The last four theorems clearly show that once the logical structure of a more intuitive MC model is known, SMC techniques can be vastly superior to the more pedestrian but, perhaps at first sight, more straight forward MC techniques.

Theorem 5. (A compendium on the four phases). The long run mean values for time-of-sojourn and (potential) transitional probabilities for embedded MC's associated with the four canonical phases are as follows:

$$\underline{sc}: \mu_{sc} = \frac{1-q^I}{pq^I} ; q_{sc,A} = 1.$$

$$\underline{uls}: \mu_{uls} = \frac{1}{fp} ; q_{uls,A} = 1.$$

$$\begin{aligned} \underline{ls}: \mu_{ls} &= \mu_{ls,A(1)} + \mu_{ls,A(2)} \\ &= \left\{ \frac{1-q^k}{fp} - q^k \left(1 + \frac{k}{f}\right) \right\} + \left\{ q^k \left(1 + \frac{k}{f}\right) \right\} \\ &= \frac{1-q^k}{fp} ; q_{ls,A(1)} = 1 - q^k \\ & \qquad \qquad \qquad q_{ls,A(2)} = q^k . \end{aligned}$$

$$\begin{aligned} \underline{ck}: \mu_{ck} &= \mu_{ck,A(1)} + \mu_{ck,A(2)} \\ &= m(1-q^m) + mq^m \\ &= m; q_{ck,A(1)} = 1 - q^m, q_{ck,A(2)} = q^m . \end{aligned}$$

Proof. If  $\{a_n\}$  is a probability sequence, then its mean is given by

$$(-zD_z \hat{a}(z)) \Big|_{z=1}$$

where  $\hat{a}(z)$  is its Z-transform. Secondly,  $H_0^* a(\infty) = \hat{a}(z) \Big|_{z=1}$ .

3.2 Self jumps and MRP's. The SMC method suggests the following considerations. If a given phase is completely ordered with a possible return to the initial MC state at each step or is only quasi ordered with possible random re-entries to each of its MC states at each step, then corresponding variant, transient SMC states can be constructed by this method by adding the phase itself as one of the exit phases. In either case, due to the alterations in the p.d.f.'s, the resultant SMC state now has self-transitions -- a fact that necessitates defining the MRP as the primary object, the induced SMC as secondary, in contrast to the "no self-jump" situation where they are equivalent. Below, this approach and some of its implications are examined for the sc and uls phases.

Theorem 6. If self-transitions are allowed for sc, we have:

$$\hat{Q}_{sc,sc}(z) = \left(\frac{p}{z-q}\right) \left(1 - \left(\frac{q}{z}\right)^I\right).$$

$$\hat{Q}_{sc,A}(z) = \left(\frac{q}{z}\right)^I.$$

Proof. a.  $H_0$  is now treated as a degenerate MC state and any return to it is considered to be a (self) transition of sc. Letting  $j = H_j$  and  $sc = A_1$ , we therefore have the following system:

$$P_{j,A_1}^n = pP_{A_1,A_1}^{n-1} + qP_{(j+1),A_1}^{n-1} \quad (0 \leq j < I-1)$$

$$P_{I-1,A_1}^n = pP_{A_1,A_1}^{n-1}.$$

b. The system in a. implies, upon Z-transforming,

$$\hat{P}_{0A_1} = \hat{H}_0 \left( \frac{p}{z} + \frac{Pq}{z^2} + \dots + \frac{Pq^{I-2}}{z^{I-1}} \right) + \left( \frac{q^{I-1}}{z^{I-1}} \right) \hat{P}_{I-1,A_1},$$

$$\text{where } \hat{P}_{I-1,A_1} = \frac{p}{z} \hat{H}_0.$$

Thus  $\hat{P}_{0,A_1} = \hat{H}_0 \left( \frac{p}{z} \right) \left( \sum_{j=0}^{I-1} \left( \frac{q}{z} \right)^j \right)$

Letting  $A(\overline{sc}) = A_1 = \overline{sc}$ , we have

$$\begin{aligned} \hat{Q}_{\overline{sc},\overline{sc}}(z) &= \left( \frac{p}{z} \right) \left( \frac{z}{z-q} \right) \left( 1 - \left( \frac{q}{z} \right)^I \right) \\ &= \left( \frac{p}{z-q} \right) \left( 1 - \left( \frac{q}{z} \right)^I \right) . \end{aligned}$$

c.  $P_{0,A_2}^n = q^I P_{A_2,A_2}^{n-I} \implies$

$$\hat{Q}_{\overline{sc},A}(z) = \left( \frac{q}{z} \right)^I .$$

Corollary 1. If  $\overline{sc}$  denotes the screening phase with self transitions as defined in Theorem 6, we have

$$\mu_{\overline{sc}} = \frac{1-q^I}{p} ; \quad q_{\overline{sc},\overline{sc}} = 1-q^I, \quad \text{and} \quad q_{\overline{sc},A} = q^I .$$

Proof.  $\mu_{\overline{sc}} = \mu_{\overline{sc},\overline{sc}} + \mu_{\overline{sc},A}$

$$= \left( \frac{1-q^I}{p} - Iq^I \right) + Iq^I$$

$$= \frac{1-q^I}{p} \quad \text{by}$$

differentiation of the Z-transform; rest is trivial.

Corollary 2. Letting  $\overline{sc}$  be as above,

$$\hat{Q}_{\overline{sc},A} = \frac{\hat{Q}_{\overline{sc},A}}{1 - \hat{Q}_{\overline{sc},\overline{sc}}} .$$

Proof.

$$\hat{Q}_{\overline{sc},A} = \left\{ \sum_{n=0}^{\infty} \left( \hat{Q}_{\overline{sc},\overline{sc}} \right)^n \right\} \hat{Q}_{\overline{sc},A} \quad \text{and}$$

fact that  $\hat{Q}_{\overline{sc},\overline{sc}}(1) = 1 - q^I < 1$ .

The expansion in the proof to Corollary 2 above can be given the following interpretation:

$$"(\hat{Q}_{\overline{sc}, \overline{sc}})^j \hat{Q}_{\overline{sc}, A}"$$

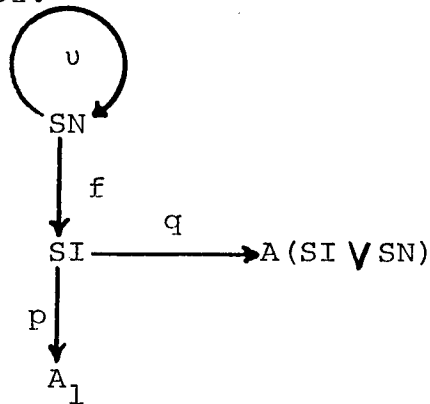
means  $j$  defects before transition. However, though the use of  $\overline{sc}$  leads to a probabilistically natural expansion for  $\hat{Q}_{\overline{sc}, A}$ , it is not necessarily the most practical (except perhaps for small  $N$ ) due to an accumulation of factorial terms; more practical complete formulas useful for all  $N$ , can be developed by considering purely analytical expansions [see Ref 7.1]. Secondly,  $\overline{sc}$  throws some light on the requirement of continued inspection after a defect is found in the  $ck$  phase;  $ck$  would be a "one-time"  $\overline{sc}$  if inspection were stopped and a transition made at this point in contrast to the usual requirement made above.

We now turn to self-jumps for the  $uls$  phase. Having in mind the situation that occurs in the SMC proof of Theorem 3 for the  $ls$  phase, we have

Theorem 7. If  $uls$  were to be allowed self-transitions which mimic any SN-SI block of the  $ls$  phase, then

$$\hat{Q}_{\overline{uls}, \overline{uls}}(z) = \frac{fq}{z-u} \text{ and } \hat{Q}_{\overline{uls}, A}(z) = \frac{\delta}{z-u} .$$

Proof. Consideration of the following diagram provides the proof:



Corollary 1.

$$\hat{Q}_{uls,A} = \frac{\hat{Q}_{uls,A}}{1 - \hat{Q}_{uls,uls}} .$$

Proof.

$$\hat{Q}_{uls,A} = \left\{ \sum_{n=0}^{\infty} (\hat{Q}_{uls,uls})^n \right\} \hat{Q}_{uls,A} .$$

Corollary 2.

$$\hat{Q}_{ls,A(1)} = \frac{\hat{Q}_{uls,A}}{1 - \hat{Q}_{uls,uls}} (1 - (\hat{Q}_{uls,uls})^k)$$

$$\hat{Q}_{ls,A(2)} = (\hat{Q}_{uls,uls})^k .$$

Proof.

$$a. \hat{Q}_{ls,A(1)} = \left\{ \sum_{j=0}^{k-1} (\hat{Q}_{uls,uls})^j \right\} \hat{Q}_{uls,A}$$

b. the second part is obvious.

Switching emphasis from the uls phase to the ls one, we can alternatively treat uls as a ls phase with k random.

It may be of interest to keep track of the number of defects found while screening; with this in mind, we have

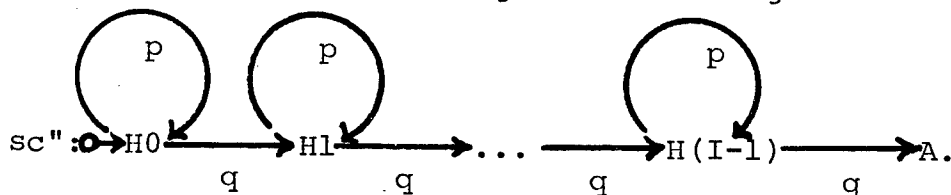
Theorem 8. Splitting sc into H0 and sc', we obtain

$$\hat{Q}_{H0,sc'} = q/(z-p), \quad \hat{Q}_{sc',H0} = (p/(z-q)) \cdot (1 - (q/z)^{I-1}),$$

$$\text{and } \hat{Q}_{sc',A} = (q/z)^{I-1} .$$

Proof. Treat  $sc'$  as  $\overline{sc}$  and use induction; rest is trivial.

Because of the complexity involved in evaluating  $\hat{Q}_{sc,A}(z)$ , one might be led to considering the following variation,



Then we easily have:

$$\begin{aligned} \hat{Q}_{sc'',A}(z) &= (\hat{Q}_{0,1}) (\hat{Q}_{1,2}) \cdot \dots \cdot (\hat{Q}_{I-1,A}) \\ &= \left(\frac{q}{z-p}\right)^I. \end{aligned}$$

Thus

$$Q_{sc'',A}(n) = \int \frac{q^I z^{n-1}}{(z-p)^I} dz = \binom{n-1}{I-1} (q^I) (p^{n-I})$$

---a result which speaks for itself. Furthermore,  $\hat{Q}_{sc'',A}(1) = 1$  which implies that  $sc''$  included in any sampling plan, in place of  $sc$ , would still yield an irreducible MC (or SMC). By considering the polynomial  $\zeta(z) = 1 - Iq^{(I-1)} + (I-1)q^I$ , we can show that, for  $0 < q < 1$ ,  $\zeta(q) > 0 \implies$  that  $\underline{\mu}_{sc''} < \underline{\mu}_{sc}$ .

Throughout the above analysis,  $\hat{Q}_{\overline{sc}, \overline{sc}}$  and  $\hat{Q}_{\overline{uls}, \overline{uls}}$  have been regarded purely function-theoretically; in Chapter 2,  $\hat{Q}_{i,j}$ ,  $i \neq j$ , has a natural probabilistic definition given within the context of a SMC. It is reasonable, therefore, to search for a corresponding interpretation for  $\hat{Q}_{j,j}$  within some similar stochastic framework. Such a framework exists-- it is a MRP. This MRP is just  $(Y_n, W_n)$ , where  $W_n$  records the  $n^{\text{th}}$  renewal. Hence if self-transitions are allowed,

$$Q_{j,j}(t) = P[W_1(j) - W_0(j) = t \mid W_0(j) = 0]$$

As noted in Chapter 2, if  $Q_{i,i} = 0$  for all  $i$ , a MRP is equivalent to its corresponding SMC; that is, while its introduction leads to some important renewal theoretical ideas which are useful in studying a SMC (see Chps. 4 & 5), it is otherwise superfluous. Moreover, if there exists only defective self-jump p.d.f.'s, the MRP can still be looked upon as only a prior necessary formality since an unique SMC can be derived from it with the following  $Q^*$ 's [Ref 7.12]: If  $A_{i,i}(+\infty) < 1$ , for all  $i$ , we have

$$\begin{aligned} \text{(SMC*): } Q_{i,j}^* &= \frac{Q_{i,j}}{1-Q_{i,i}}, \text{ if } Q_{i,i} \neq 0 \\ &= Q_{i,j}, \text{ if } Q_{i,i} = 0. \end{aligned}$$

In contrast to the two previous cases, if there is a  $j$  such that  $A_{j,j}(+\infty) = 1$ , there is then no longer a uniquely derivable SMC; for example, a one dimensional renewal process leads to a trivial SMC -- but a trivial SMC leads to any 1 dimensional renewal process. In other words, a SMC doesn't record self-jumps; a MRP does. This is the essential difference between the two concepts. Proposition 4.1 further shows that, as far as the constructive technique considered in this paper is concerned, the distinction between the two processes is irrelevant.

4.0 SAMPLING PLANS AND FI(N). CSP-1 and (generalized) CSP-2, the first two moments of the FI(N) functional defined on them for the Job Shop entry case, and the connections between the intercalation of self transitions into these plans and Markov Renewal Theory are investigated in detail. Other standard but more complex plans are then briefly treated. However, to more fully appreciate the practical results of this chapter as well as to gain further insight into the basic method, some general statements are first demonstrated.



4.1 Preservation of properties. Since we are at last ready to deal with MC's in their entirety, rather than just selected pieces of them, the preservation of certain properties in the construction of a SMC from a given MC becomes a primary concern. We first prove

Proposition 1. Given a MC from which two SMC's are constructed: SMC' is constructed using self-transitions for one MC-state (or phase); SMC, on the other hand, is constructed in same manner as SMC' except without self-transitions. Then the two SMC's are equivalent in the sense that their sample paths are the same (and the transitional probabilities are equal).

Proof.

a. Let  $j$  be a non degenerate MC state with possibly multiple entries and exits. Given any exit MC state  $k$  for  $j$  ( $k \neq j$ ), we then have

$$\hat{Q}_{j,k} = \left\{ \sum_{m=0}^{\infty} (\hat{Q}_{j,j}^m) \right\} \hat{Q}_{j,k}$$

or

$$\hat{Q}_{j,k} = \frac{\hat{Q}_{j,k}}{1 - \hat{Q}_{j,j}},$$

where,  $\hat{Q}_{j,j}(1) < 1$  since the MC is irreducible.

$$b. \hat{P}_{j,j} = \sum_{h \neq j} \hat{Q}_{j,h} \hat{P}_{h,j} + \hat{Q}_{j,j} \hat{P}_{j,j} + \hat{J}_j$$

$$\text{or } \hat{P}_{j,j}(1 - \hat{Q}_{j,j}) = \sum \hat{Q}_{j,h} \hat{P}_{h,j} + \hat{H}_0(1 - \hat{Q}_{j,j})$$

$$\text{or } \hat{P}_{j,j} = \sum \frac{\hat{Q}_{j,h}}{(1 - \hat{Q}_{j,j})} \hat{P}_{h,j} + \hat{H}_0 \left( 1 - \sum_s \frac{\hat{Q}_{j,s}}{(1 - \hat{Q}_{j,j})} \right)$$

$$\text{or } \hat{P}_{j,j} = \sum \hat{Q}_{j,h} \hat{P}_{h,j} + \hat{J}_j \text{ by a. .}$$

Similarly,

$$\hat{P}'_{m,n} = \sum \hat{Q}_{m,h} \hat{P}_{h,n} \text{ for } m \text{ and/or } n \text{ not equal to } j.$$

c. The primed quantities bear the same relationships among themselves, via the  $\hat{Q}$ 's, as the unprimed.

Theorem 1. The four principal properties of time-homogeneity, finiteness of states, irreducibility, and aperiodicity are preserved.

Proof.

a. All four properties are trivially true for the given MC.

b. By taking in account the SMC method and the concept of filtration [Ref 7.6, Chp 8], it is obvious that, once the term "canonical" is dropped, one can construct a multitude of SMC's from the MC which in turn can be considered to be the basic SMC; in other words, from the MC, a primitive SMC can be constructed by treating each MC state as a degenerate SMC state regardless of phase segmentation; in particular, if a MC state has self-transitions, then self-jumps must be introduced for this state; by Proposition 1 and a., the resulting SMC (MRP) is equivalent to the original MC.

c. Any other type of SMC constructed from this MC is a filtration of the primitive one.

d. According to [Ref 7.6, Chp 8], filtrations preserve all four of the properties.

Corollary. Let  $i$  be a state of an (irreducible) SMC constructed from a given (irreducible) MC; let  $M_i$  be the MC states contained in  $i$  but also considered as degenerate SMC states in the original MC. Then

$$\alpha_i = \sum_{s \in M_i} \alpha_s$$

Proof. a. Proposition 1 implies that  $\alpha_s$  is self-transition independent. b. The equality follows from a. and Theorem 1 on the filtration of a SMC.

Before proceeding to the next section, we prove a statement on the rapidity of convergence of a solution to a certain type of renewal equation.

Proposition 2. Given three sequences  $\{a_n\}$ ,  $\{b_n\}$ , and  $\{c_n\}$  such that (i)  $c_n = (a * c)_n + b_n$ , (ii)  $a_n, b_n \geq 0$  for all  $n$ , and (iii)  $\text{g.c.d. } \{k/a_k > x^0\} = 1$ . Then, if

$$\sum n^k b_n < +\infty \text{ and } \sum n^{k+1} a_n < +\infty,$$

we have

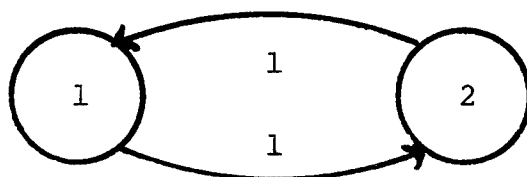
$$c_n = \frac{(H_0 * b)(n)}{(H_0 * \langle a \rangle)(n)} + o(n^{-k})$$

where  $\langle a \rangle(n) = na(n)$ .

Proof. [Ref 7.10, esp. Thm. 4].

## 4.2 Sampling plans.

4.2.1 CSP-1. Upon setting  $sc = 1$  and  $uls = 2$ , CSP-1 has the following SMC transitional diagram:



with states  $(1; \hat{Q}_{12}(z))$  and  $(2; \hat{Q}_{21}(z))$ ; the SMC diagram above should be carefully distinguished from the box one in Figure 5, Chapter 2 which is a MC transitional diagram. Since  $\hat{Q}_{12}(1) = 1 = \hat{Q}_{21}(1)$ , the corresponding embedded MC has the transitional matrix

$$T = \begin{matrix} & \begin{matrix} 1 & 2 \end{matrix} \\ \begin{matrix} 1 \\ 2 \end{matrix} & \begin{bmatrix} 0 & 1 \\ 1 & 0 \end{bmatrix} \end{matrix}$$

which is periodic with period two; however, the SMC itself is aperiodic by Theorem 3.3 since  $\text{supp}(Q_{12}) = \{I + \lambda/\lambda = 0 \text{ to } \infty\}$ .

From Theorem 2.2, we can easily write down the Z-transformed (F.S.) for CSP-1:

$$\hat{P}_{11} = \frac{\hat{J}_1}{S(z)}, \quad \hat{P}_{12} = \frac{\hat{Q}_{12}\hat{J}_2}{S(z)}$$

$$\hat{P}_{21} = \frac{\hat{Q}_{21}\hat{J}_1}{S(z)}, \quad \hat{P}_{22} = \frac{\hat{J}_2}{S(z)}$$

where

$$S(z) = 1 - \hat{Q}_{12}\hat{Q}_{21}.$$

Because of the simplicity of CSP-1, the above system can be written down directly from combinatorial principles.

The eigen-vector equation,  $\underline{e}^T = \underline{e}$ , for CSP-1 yields  $\underline{e} = (1/2, 1/2)$  as a solution; therefore, using  $\mu_{sc}$  and  $\mu_{uls}$  from Theorem 3.5 we have, by Theorem 2.4:

$$P_{sc}^{(\infty)} = \alpha_{sc} = \frac{f(1-q^I)}{f(1-q^I)+q^I},$$

$$P_{uls}^{(\infty)} = \alpha_{uls} = \frac{q^I}{f(1-q^I)+q^I},$$

results which can also be obtained directly from the Z-transformed (F.S.) through additional use of l'Hospital's rule. From Proposition 2.3, we also have:

$$\hat{F}_{12} = \hat{Q}_{12}, \quad \hat{F}_{21} = \hat{Q}_{21}, \quad \hat{F}_{11} = \hat{Q}_{12}\hat{Q}_{21},$$

and  $\hat{F}_{22} = \hat{Q}_{21}\hat{Q}_{12} (= \hat{F}_{11})$ .

An application of Proposition 2 is found in

Theorem 1.

$$P_{12}(n) = \frac{H_0 * Q_{21} * J_2(n)}{H_0 * \langle F_{11} \rangle(n)} + o(n^{-k}),$$

for arbitrary k.

Proof.

$$\begin{aligned}
 \text{a. } P_{12} &= Q_{12} * P_{22} \\
 P_{22} &= Q_{21} * P_{12} + J_2 \\
 P_{12} &= (Q_{12} * Q_{21}) * P_{12} + Q_{21} * J_2 \\
 &= F_{11} * P_{12} + Q_{21} * J_2
 \end{aligned}
 \left. \vphantom{\begin{aligned} P_{12} \\ P_{22} \\ P_{12} \end{aligned}} \right\} \Longrightarrow$$

$$\begin{aligned}
 \text{b. } \sum n^k (Q_{21} * J_2)(n) &< + \infty \\
 \sum n^{k+1} F_{11}(n) &< + \infty
 \end{aligned}$$

which follows from Theorems 3.1 and 3.2 along with repeated differentiation of the transforms to obtain the higher moments.

c. We are done by a., b., and Proposition 2.

Corollary. (l'Hospital's rule from a renewal eq.)

$$\lim_{n \rightarrow \infty} P_{12}(n) = \frac{\hat{b}(z)}{-z D_z F_{11}(z)} \Big|_{z=1}.$$

where  $b(n) = Q_{21} * J_2(n)$ .

Proof.

a.  $c_n = a * c_n + b_n$  with conditions of Proposition 2 holding for  $k = 0$ , then, if  $H_0 * a(\infty) = 1$ , we have

$$\hat{c}(z) = \frac{\hat{b}(z)}{1 - \hat{a}(z)}.$$

b. Therefore, from a.,

$$\begin{aligned}
 \lim_{z \rightarrow 1} \frac{z-1}{z} \hat{c}(z) &= \lim_{z \rightarrow 1} \frac{z-1}{z} \frac{\hat{b}(z)}{1 - \hat{a}(z)} \\
 &= \lim_{z \rightarrow 1} \frac{\hat{b}(z)}{-z \left( \frac{\hat{a}(z) - \hat{a}(1)}{z-1} \right)} \\
 &= \frac{\hat{b}(z)}{-z \hat{a}'(z)} \Big|_{z=1}.
 \end{aligned}$$

c. But  $c(\infty) =$  the limit on the L.H.S. in b. . Therefore we are done by letting  $a = F_{11}$ .

Of importance in analyzing the  $FI(N)$  function is the monotonicity of  $P_{12}(\cdot)$  and  $P_{22}(\cdot)$ . We prove

Theorem 2. (Monotonicity)  $P_{12}(n)$

or  $P_{22}(n)$  is monotonically nondecreasing or nonincreasing respectively.

Proof.

$$\begin{aligned} \text{a. } \Delta P_{11}(n) &= P_{11}(n+1) - P_{11}(n) \\ &= -Q_{12}(n) + \sum_{j=1}^{\infty} (F_{11}^{(j)}(n) - F_{11}^{(j)} * Q_{12}(n)) \end{aligned}$$

$$\begin{aligned} \text{b. } F_{11}^{(j)} * Q_{12}(n) - F_{11}^{(j)}(n) &= P[W_j(1) + T_{1,2} = n] - P[W_j(1) = n] \\ &= P[W_j(1) + T_{12} = n \text{ and } T_{12} \neq 0] \\ &\geq 0, \end{aligned}$$

c. Thus  $\Delta P_{11}(n) \leq 0$  from a. and b. .

d.  $P_{12}(n) = (H_0 - P_{11})(n)$  and c. imply  $\Delta P_{12}(n) \geq 0$ .

In the same way we can show that  $P_{22}(n) \leq 0$  which finishes the proof.

Before moving on to CSP-2, we prove a statement concerning the roots of the fundamental polynomial (F.P.) of CSP-1.

Proposition 3. The denominator of rational function

$$\frac{1}{1 - \hat{Q}_{12}(z)\hat{Q}_{21}(z)}$$

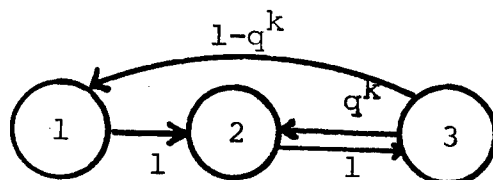
is  $FP(z) =$

$$(z-q)(z^I - pz^{I-1} - pqz^{I-2} - \dots - pq^{I-1}).$$

Proof.  $FP(z) = \phi(z) - \delta q^I(z-q)$   
 from Theorems 3.1 and 3.2.

In [Ref 7.1],  $FP(z)$  is obtained directly as  $z^I(z-\beta)+\theta$ ,  $\theta = fpq^I$   $\beta = 1-\delta$ ; thus the SMC approach gives some insight into the root distribution of  $FP(z)$ .

4.2.2 CSP-2. Upon letting 1 = sc, 2 = uls, and 3 = ls, CSP-2 has the following SMC transitional diagram:



with states (1;  $\hat{Q}_{12}(z)$ ), (2;  $\hat{Q}_{23}(z)$ ), and (3;  $\hat{Q}_{31}(z)$ ,  $\hat{Q}_{32}(z)$ ); once again the SMC diagram should be carefully distinguished from the one in Figure 5, Chapter 2. Since, in addition to  $\hat{Q}_{12}(1) = 1 = \hat{Q}_{21}(1)$ , we also have  $\hat{Q}_{31}(1) = 1-qk$  and  $\hat{Q}_{32}(1) = qk$ , the embedded MC has a transitional matrix

$$T = \begin{matrix} & \begin{matrix} 1 & 2 & 3 \end{matrix} \\ \begin{matrix} 1 \\ 2 \\ 3 \end{matrix} & \begin{bmatrix} 0 & 1 & 0 \\ 0 & 0 & 1 \\ 1-q^k & q^k & 0 \end{bmatrix} \end{matrix}$$

which is however aperiodic; again the SMC is aperiodic for exactly the same reasons it is for CSP-1.

Because of the increased complexity of CSP-2, we proceed to derive the basic transitional probabilities more formally than with CSP-1.

Proposition 4. Transitional probabilities of CSP-2 (first row).

$$\hat{P}_{11} = \frac{\hat{H}_0 (1 - \hat{Q}_{12}) (1 - \hat{Q}_{23} \hat{Q}_{32})}{\hat{G}}$$

$$\hat{P}_{12} = \frac{\hat{Q}_{12} \hat{H}_0 (1 - \hat{Q}_{23})}{\hat{G}}$$

$$\hat{P}_{13} = \frac{\hat{Q}_{12} \hat{Q}_{23} \hat{H}_0 (1 - (\hat{Q}_{31} + \hat{Q}_{32}))}{\hat{G}},$$

where  $\hat{G} = 1 - \hat{Q}_{23} (\hat{Q}_{32} + \hat{Q}_{31} \hat{Q}_{12})$ .

Proof. (F.S.) for CSP-2, Z-transform, and Cramer's rule for linear algebraic systems which holds since there exists an R such that  $|z| > R \Rightarrow \hat{G}(z) \neq 0$ .

Upon solving the eigen vector equation for the embedded MC in the CSP-2 case, we obtain

$$\begin{aligned} \underline{e} &= \left( \frac{1 - q^k}{c}, \frac{1}{c}, \frac{1}{c} \right) \\ &= (e_1, e_2, e_2), \end{aligned}$$

where  $c = 3 - q^k$ . Combining this result with Theorems 3.1, 3.2, 3.3, and 2.4, we have

$$P_{sc}(\infty) = \alpha_{sc} = \frac{f(1 - q^k)(1 - q^I)}{D}$$

$$P_{uls}(\infty) = \alpha_{uls} = \frac{q^I}{D}$$

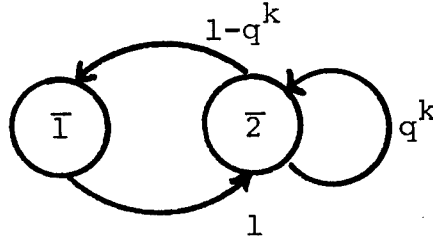
$$P_{1s}(\infty) = \alpha_{1s} = \frac{q^I(1 - q^k)}{D},$$

where  $D = (f)(1 - q^k)(1 - q^I) + (2 - q^k)(q^I)$ .

For future use in studying the FI(N) functional for CSP-2, we now give an example of the uses of filtration to combine SMC states 2 and 3 into one (super) state with and without self jumps.



Case 1: self-jumps.



In this case, we are allowing the events 2→2, 2→1, and 1→2 to filter through; thus the filtered set is just {3}. The corresponding states of the filtered SMC, whose transitional diagram appears above, are  $(\bar{1}; \hat{Q}_{\bar{1},\bar{2}})$  and

$(\bar{2}; \hat{Q}_{23}\hat{Q}_{31}, \hat{Q}_{23}\hat{Q}_{32})$

where

$$\hat{Q}_{\bar{2},\bar{1}} = \hat{Q}_{23}\hat{Q}_{31} ,$$

$$\hat{Q}_{\bar{2},\bar{2}} = \hat{Q}_{23}\hat{Q}_{32} ,$$

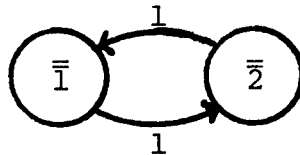
and

$$\hat{Q}_{\bar{1},\bar{2}} = \hat{Q}_{12} .$$

The transitional matrix of the filtered SMC's embedded MC is

$$\begin{array}{c} \bar{1} \\ \bar{2} \end{array} \begin{bmatrix} \bar{1} & \bar{2} \\ 0 & 1 \\ q^k & 1-q^k \end{bmatrix}$$

Case 2: No self-jumps.



In this case, we are only allowing the events 2→1 and 1→2 to filter through; thus the filtered set is again {3}. However, the corresponding states of this filtered SMC are now

$$(\bar{1}; \hat{Q}_{\bar{1}\bar{2}}) \text{ and } (\bar{2}; \frac{\hat{Q}_{23}\hat{Q}_{32}}{1-\hat{Q}_{23}\hat{Q}_{32}})$$

$$\text{since } \hat{Q}_{\bar{2},\bar{1}} = \hat{Q}_{23} \left\{ \sum_{j=0}^{\infty} (\hat{Q}_{32}\hat{Q}_{23})^j \right\} \hat{Q}_{31}.$$

Again for future application to the analysis of FI(N), we use Case 1 to prove

Theorem 3. (Expansion theorem)

$$P_{\bar{1},\bar{2}}(n) = \{ (1)P_{1,2} * (\delta_0 + {}_1R_{223}) * S \}(n)$$

where

$$S(n) = \sum_{j=0}^{\infty} (1)^j \{ (\Delta({}_1P_{12})) * {}_1R_{223} \}^{(j)}$$

which converges for  $\frac{\mu_2}{\mu_1 + \mu_2} \left( \frac{1}{1-qk} \right) < 1$ .

"(1)" is CSP-1, 1 = sc, 2 = uls, and

$${}_1R_{223}(n) = P[x(n)=3 \mid x(n-1)=2, x(0)=2 \text{ and } x(k) \neq 1, 0 < k < n-1].$$

Proof. For convenience, let  $\hat{Q}_{ab} = x_{ab}$  and  $\hat{Q}_{\bar{a}\bar{b}} = \bar{x}_{a,b}$  if the latter is different from the former.

a. Using this notation, we have, from the (F.S.) for the filtered SMC,

$$\hat{P}_{\bar{1},\bar{2}} = \frac{\hat{H}_0 x_{12} (1 - (\bar{x}_{21} + \bar{x}_{22}))}{1 - (x_{12} \bar{x}_{21} + \bar{x}_{22})}.$$

$$\text{b. } 1 - \bar{x}_{22} - x_{12} \bar{x}_{21}$$

$$= 1 - \bar{x}_{22} - x_{12} x_{23} x_{31}$$

$$= 1 - \bar{x}_{22} - x_{12} x_{23} (x_{23} \bar{x}_{22})$$

$$\begin{aligned}
&= (1-\bar{x}_{22}) - x_{12}x_{23}[(1-\bar{x}_{22})+(1-x_{23})] \\
&= (1-\bar{x}_{22})(1-x_{12}x_{23}) + (1-x_{23})x_{12}x_{23} \\
&= (1-\bar{x}_{22})(1-x_{12}x_{23})(1+\hat{a})
\end{aligned}$$

where  $\hat{a} = \frac{x_{12}(1-x_{23})}{(1-x_{12}x_{23})} \left( \frac{x_{23}}{1-\bar{x}_{22}} \right)$ .

c.  $x_{12}(1-(\bar{x}_{21}+\bar{x}_{22})) = x_{12}(1-x_{23})(1+x_{31})$

since  $x_{31} = x_{23} - \bar{x}_{22}$

d. a., b., and c. therefore give

$$\begin{aligned}
\hat{P}_{12} &= \frac{\hat{H}_0 x_{12} (1-x_{23})}{(1-x_{12}x_{23})} \frac{(1+x_{31})}{(1-\bar{x}_{22})} \left( \frac{1}{1+\hat{a}} \right) \\
&= (1)^{\hat{P}_{12}} \left( 1 + \frac{x_{23}}{1-\bar{x}_{22}} \right) \left( \frac{1}{1+\hat{a}} \right),
\end{aligned}$$

which is just the Z-transform of the assertion; we finish this part by noting that  $\hat{Q}_{23} = \hat{Q}_{21}$  for CSP-1.

e. This factored expression approaches

$$\left( \frac{\mu_2}{\mu_1 + \mu_2} \right) \left( 1 + \frac{1}{1-q^k} \right) \left( \frac{1}{1 + \left( \frac{\mu_2}{\mu_1 + \mu_2} \right) \left( \frac{1}{1-q^k} \right)} \right);$$

however we also have, for the third factor,

$$\text{Lim}_{z \rightarrow 1} \hat{a}(z) = \text{Lim}_{z \rightarrow 1} \hat{H}_0^{-1} (\hat{H}_0 \hat{a}(z))$$

$$= \lim_{z \rightarrow 1} \hat{H}_0^{-1} \hat{b}(z)$$

=  $b(\infty)$ , endpoint property.

$$= H_0 * a(\infty)$$

$$= \left( \frac{\mu_2}{\mu_1 + \mu_2} \right) \left( \frac{1}{1-q^k} \right)$$

$$\geq a(n), \text{ for all } n;$$

thus the conv. criterion suffices.

4.3 FI(N) functional. Before embarking on a detailed examination of the moments of FI(N), the following fundamental theorem is proven to illuminate the analysis of variance.

Theorem 4. Let  $\{a_n\}$  and  $\{b_n\}$  be two positive sequences such that (i)  $a_n \uparrow$  or  $\downarrow A$  and (ii)  $b_n \uparrow$  or  $\downarrow B$  as  $n \rightarrow \infty$ . Then

$$\frac{\sum_{k=0}^N (a*b)(k)}{N^2} \rightarrow \frac{1}{2} AB.$$

Proof. We will only prove this for  $a_n \uparrow A$  and  $b_n \uparrow B$ .

$$\begin{aligned} \text{a. } & \frac{\sum (a-A) * (b-B)}{N^2} \\ &= \frac{\sum a*b}{N^2} + \frac{(H_0^2 * a)(N)}{N^2} (B) \\ &+ \frac{(H_0^2 * b)(N)}{N^2} (A) - \frac{H_0^3(N)}{N^2} AB, \end{aligned}$$

where  $H_0^k = H_0 * \dots * H_0$  k times.

$$\begin{aligned}
 \text{b. } 0 &\leq \frac{\Sigma(a-A) * (b-B)}{N^2} \\
 &\leq \left(\frac{\Sigma(a-A)}{N}\right) \left(\frac{\Sigma(b-B)}{N}\right)
 \end{aligned}$$

which approaches zero as  $N \rightarrow \infty$  since ordinary convergence implies  $C_1$  conv.

$$\begin{aligned}
 \text{c. } &\frac{(H_0^2 * a)(N)}{N^2} \\
 &= \left(1 + \frac{1}{N}\right) \frac{H_0 * a(N)}{N} - \frac{H_0 * \langle a \rangle (n)}{N^2} ; \\
 \text{but } &\frac{H_0 * \langle a \rangle (n)}{N^2}
 \end{aligned}$$

$$\begin{aligned}
 &= \frac{\sum_{n=0}^N n a_n}{N^2} \\
 &= A \frac{(\Sigma n)}{N^2} + \frac{\sum n (a_n - A)}{N^2} \\
 &\leq \frac{AN(N+1)}{2N^2} + \frac{\sum N(a_n - A)}{N^2} \\
 &= \frac{A}{2} \left(1 + \frac{1}{N}\right) + \frac{\sum (a_n - A)}{N} \rightarrow \frac{A}{2} .
 \end{aligned}$$

$$\begin{aligned}
 \text{d. } &\frac{H_0 * \langle H_0 \rangle (N)}{N^2} \\
 &= \frac{\sum r}{N^2} \\
 &= \frac{N(N+1)}{2N^2} \rightarrow 1/2 \text{ as } N \rightarrow \infty ;
 \end{aligned}$$

therefore

$$\frac{H_0^3(N)}{N^2} = \left(1 + \frac{1}{N}\right) \frac{H_0^2(N)}{N^2} - \frac{H_0^* \langle H_0 \rangle (N)}{N^2} \longrightarrow$$

$$1 - 1/2 = 1/2, \text{ as } N \rightarrow \infty.$$

$$e. \quad \left(1 + \frac{1}{N}\right) \frac{H_0^* a(N)}{N} - \frac{H_0^* \langle a \rangle (N)}{N^2} \longrightarrow A - \frac{1}{2}A = \frac{1}{2}A$$

$$\left(1 + \frac{1}{N}\right) \frac{H_0^* b(N)}{N} - \frac{H_0^* \langle b \rangle (N)}{N^2} \longrightarrow B - \frac{1}{2}B = \frac{1}{2}B$$

from c. and the hypotheses, as  $N \rightarrow \infty$ .

f. Thus the whole expression approaches

$$0 + \frac{1}{2}AB + \frac{1}{2}AB - \frac{1}{2}AB$$

$$= \frac{1}{2}AB \text{ by e., d., and a. .}$$

4.3.1 CSP-1, Job Shop entry. The form  $FI(N)$  takes for this MC is

$$FI(N) = 1 - \frac{\sum_{j=0}^N M_{SN}^{(j)}}{N}$$

Thus here we want  $E_{(H_0)}[FI(N)]$  which is

$$1 - \frac{1}{N} \sum_{j=0}^N P_{H_0, SN}^j$$

$$= AFI(N).$$

However, since

$v = P[SN | uls]$ ,  
we have

$$v P_{sc, uls}^j = P_{H_0, SN}^j$$

or

$$E_{sc}(v X_2(j)) = E_{H_0}[M_{SN}^{(j)}].$$

Summing up, keeping the monotonic growth property of  $P_{sc,uls}(\cdot)$  in mind, we have

Theorem 5.

$$AFI(N) = 1 - \frac{u}{N} \sum_{j=0}^N P_{sc,uls}(j);$$

$AFI(N) \downarrow u\alpha_{uls}$  as  $N \rightarrow \infty$ .

Since  $\text{Var}(1-W) = \text{Var}(W)$  and  $\text{Var}(W) = E[W^2] - (E[W])^2$ , we will henceforth generally restrict the discussion to second moments of  $W$ . To deal with the variance of  $FI(N)$  in the MC case requires that the following expression be considered:

$$E_{H0} [M_{SN}(j)M_{SN}(j+k)] = P_{H0,SN}^j P_{SN,SN}^k,$$

$0 \leq j, k \leq N$ . However, since the variance for CSP-1, J-S entry, is treated from this view point in [7.1], we will use the 2 state SMC for CSP-1 -- relating the results to those obtained for the MC model; for a treatment of variance which uses a three state SMC (i.e., sc, SN, and SI), see Chapter 5.

Proposition 5. Letting  $sc = 1$  and  $uls = 2$ ,

$$E_1 [X_2(n)X_2(n+k)] = P_{12}(n)P_{22}(k).$$

Proof.

$$\begin{aligned} & a. \quad P[X(0)=1, X(n)=2, X(n+k)=2] \\ & = \quad P[M(0)=H0, M(n)=SN \vee SI, M(n+k)=SN \vee SI] \\ & = \quad P[M(n)=SN \vee SI \mid M(0)=H0] P[M(n+k)=SN \vee SI \mid M(n)=SN \vee SI] \\ & = \quad P_{12}(n)P_{22}(k). \end{aligned}$$

b. The result can also be seen by treating 2 as degenerate such that at each step either 2→2 with probability  $\beta$  or 2→1 with probability  $\delta$ .

Let us consider

$$E_1 \left[ \left( \frac{\sum v X_2(j)}{N} \right)^2 \right] = E_1 [W^2].$$

Using the convolution and proposition 5, we have

$$E_1 [W^2] = \frac{2v^2}{N^2} H_0 * P_{12} * P_{22} (N) - \frac{vm_N}{N^2}$$

where  $m_N = E_1 [1-W]$ . Now, we further have

$$P_{SN,SN}^n \vee_{SI,SN} = v P_{SN,SN}^n + f P_{SI,SN}^n \quad (1)$$

$$\begin{aligned} P_{SI,SN}^n &= q(f P_{SI,SN}^{n-1} + v P_{SN,SN}^{n-1}) + p P_{HO,SN}^{n-1} \\ &= q P_{SN,SN}^{n-1} \vee_{SI,SN} + p P_{HO,SN}^{n-1} \end{aligned} \quad (2)$$

Therefore, substituting (2) into (1), we have

$$P_{SN,SN}^n \vee_{SI,SN} = v P_{SN,SN}^n + f q P_{SN,SN}^{n-1} \vee_{SI,SN} + f p P_{HO,SN}^{n-1}$$

or

$$v P_{2,2} (n) = v P_{SN,SN}^n + f q v P_{2,2} (n-1) + f p v P_{1,2} (n-1)$$

or

$$P_{2,2} (n) - f q P_{2,2} (n-1) - f p P_{1,2} (n-1) = P_{SN,SN}^n \quad (3).$$

Thus from (3) we have

$$\begin{aligned} &\frac{2v}{N^2} (H_0 * P_{12} * P_{22} (N) - (f q) H_0 * P_{12} * P_{22} (N-1)) \\ &- (f p) H_0 * P_{12} * P_{12} (N-1) - \frac{vm_N}{N^2} \end{aligned}$$



$= E_{HO} [(1-FI(N))^2]$ . Thus bounds can be developed for the 2-state SMC and then translated into bounds for the MC or primitive SMC; Theorem 5 also shows the proper convergence (hence the factor 2).

4.3.2 CSP-2, J-S entry. For this plan, the MC formula is

$$FI(N) = 1 - \frac{1}{N} \left\{ \sum_{s=0}^N M_{SN}(s) + \sum_{j=0}^{k-1} \sum_{s=0}^N M_{SNj}(s) \right\}.$$

Because of the fact that we can consider  $\bar{2}$  as being randomly entered at each step, given that it is entered, we have

Proposition 6. Letting  $\bar{1} = sc$  and  $\bar{2} = uls$  for the self-jump filtration of CSP-2, we have

$$vE_{\bar{1}}[X_{\bar{2}}(s)] = \sum_{j=0}^{k-1} E_{HO}[M_{SNj}(s)] + E_{HO}[M_{SN}(s)].$$

Proof.

$$\begin{aligned} vP_{\bar{1},\bar{2}}(s) &= \sum_{j=-1}^{k-1} vP_{\bar{1},j} \\ &= \sum_{j=-1}^{k-1} P_{\bar{1},SNj} \end{aligned}$$

where  $SN(-1) = SN$ . Thus we have

Theorem 6. For CSP-2,

$$AFI(N) = 1 - \frac{v}{N} \sum_{s=0}^N P_{\bar{1},\bar{2}}(s).$$

$P_{\bar{1},\bar{2}}(s)$  can be expanded in terms of  $(1)P_{12}(s)$  by Theorem 3 and therefore  $(2)AFI(N)$  can in turn be expanded in terms of  $(1)AFI(N)$ .

To deal with the variance for CSP-2, we will split the 1s state (phase) into k new (sub) states in order to make use of the convolution as in

Proposition 7. Letting  $a=1=sc$ ,  $(SN-SI)=uls=-1$ , and  $(SNj-SIj)=j$ , we have

$$P[X(0)=a, X(n)=j_1, X(n+s)=j_2] = P_{aj_1}^{(n)} P_{j_1, j_2}^{(s)}$$

where  $j, (j_2)$  range from  $-1$  to  $k-1$ .

Proof. As in Proposition 5.

Proceeding as in the CSP-1 case, we can express the variance in terms of the states  $a$ , and  $j$ ,  $-1 \leq j \leq k-1$ . Thus we will restrict our attention to

$$\begin{aligned} & E_a \left[ \left( \sum_{j=-1}^{k-1} \frac{\sum_{s=0}^N X_j(s)}{N} \right)^2 \right] \\ &= E_a \left[ \left( \frac{1}{N} \sum_{j=1}^{k-1} D_j \right)^2 \right] \\ &= E_a \left[ \frac{\sum D_j^2}{N^2} + \frac{\sum D_j D_{j'}}{N^2} + \frac{\sum D_j D_j}{N^2} \right]. \end{aligned}$$

Use of the convolution and Proposition 7 gives

$$\begin{aligned} \frac{1}{N^2} E_a [D_j^2] &= \frac{2H_0 * P_{aj} * P_{jj}(N)}{N^2} - \frac{H_0 * P_{a,j}(N)}{N^2} \\ \frac{1}{N^2} E_a [D_j D_{j'}] &= \frac{1}{N^2} E_a [D_j D_j] \\ &= \frac{H_0 * P_{aj} * P_{j,j'}(N)}{N^2} + \frac{H_0 * P_{a,j'} * P_{j',j}(N)}{N^2} \end{aligned}$$

since  $P_{jj'}(0) = P_{j'j}(0) = 0$  if  $j \neq j'$ .

Summing up, we have

Theorem 7.

$$\begin{aligned}
 & E_a [(1-FI(N))^2] \\
 &= \frac{1}{N^2} \sum_{j=-1}^{k-1} \{ 2H_0 * P_{aj} * P_{j,j}(N) + 2H_0 * P_{aj} * P_{jj'}(N) \\
 &+ 2H_0 * P_{1j'} * P_{j',j}(N) - H_0 * P_{a,j}(N) \}.
 \end{aligned}$$

We note that as  $N \rightarrow \infty$ , the expression in Theorem 7 approaches

$$\begin{aligned}
 & \sum_{j=-1}^{k-1} m_j^2 + 2 \sum_{j < j'} m_j m_{j'} \\
 &= \left( \sum_{j=-1}^{k-1} m_j \right)^2 \text{ by Theorem 4.}
 \end{aligned}$$

Readjusting notation again,  $sc=a$ ,  $uls=b$ , otherwise the same, we can rewrite the non-negative terms of Theorem 7 as follows (factoring out  $2/N^2$ )

$$\begin{aligned}
 & H_0 * P_{ab} * \left( \sum_{j=0}^{k-1} P_{bj} + P_{bb} \right) \\
 & \quad + \\
 & \quad \cdot \\
 & \quad \cdot \\
 & \quad + \\
 & H_0 * P_{as} * \left( \sum_{j=0}^{k-1} P_{sj} + P_{sb} \right)
 \end{aligned}$$

for  $0 \leq s \leq k-1$ .

Letting  $U_s = \sum P_{sj} + P_{sb}$ , including  $s=b$ , we have the following equations:

$\hat{P}_{ab}(\hat{U}_b), \dots, \hat{P}_{a(k-1)}(\hat{U}_{k-1})$  with states  $a, b, o, \dots,$   
 $(k-1)$  and transformed p.d.f.'s  $y_o = \hat{Q}_{b,o} = \delta/(z-\beta);$   
 $y_a = \hat{Q}_{j,a} = \delta/(z-\nu)$  for  $0 \leq j \leq k-1;$   $y = \hat{Q}_{j,j+1} = fq/(z-\nu)$   
 (for  $0 \leq j \leq k-1$ ) =  $Q_{k-1,b}$ .

Using the Z-transform, we obtain the following relationships among the  $U_s$ 's above.

$$\begin{aligned} \hat{U}_b &= y_o \hat{U}_o + \hat{H}_o(1-y_o) \\ \hat{U}_o &= y \hat{U}_1 + \hat{H}_o(1-y-y_a) + y_a \hat{A} \\ &\vdots \\ \hat{U}_{k-1} &= y \hat{U}_b + \hat{H}_o(1-y-y_a) + y_a \hat{A} \end{aligned}$$

where  $\hat{A} = \sum_{j=0}^{k-1} \hat{P}_{aj} + \hat{P}_{ab}$ . We also have

$$\begin{aligned} \hat{H}_o(1-y) &= z/(z-\beta) = \hat{J}_b \implies \|\hat{J}_b\|_N = \beta^N \\ \hat{H}_o(1-y-y_a) &= z/(z-\nu) = \hat{J}_s \implies \|\hat{J}_s\|_N = \nu^N \end{aligned}$$

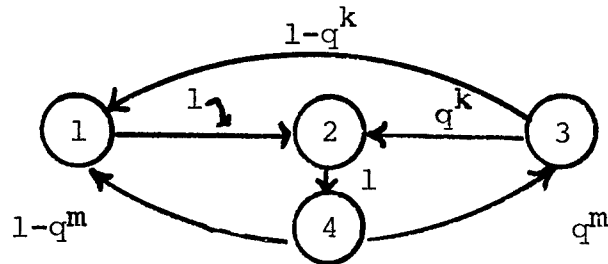
where  $\|a\|_N = H_o * a(N)$ .

Using this system, we can progressively get bound's on the  $U_j$ 's and therefore eventually on the variance for  $FI(N)$ . For instance, letting  $k=1$ , we would have:

$$\begin{aligned} \|U_b\|_N &\leq (1-\beta^N) \|U_o\|_N + \beta^N \\ \|U_o\|_N &\leq q(1-\nu^N) \|U_1\|_N + P(1-\nu^N) \|A\|_N + \nu^N \\ \|U_1\|_N &\leq q(1-\nu^N) \|U_b\|_N + P(1-\nu^N) \|A\|_N + \nu^N \end{aligned}$$

Working out a full-blown expression for a bound on the variance is extremely tedious, but now possible.

4.4 Other sampling plans. Setting 1=sc, 2=uls, 3=ls, and 4=ck, the SMC transitional diagram of CSP-3 is:



with states  $(1; \hat{Q}_{12})$ ,  $(2; \hat{Q}_{24})$ ,  $(3; \hat{Q}_{31}, \hat{Q}_{32})$ , and  $(4; \hat{Q}_{41}, \hat{Q}_{43})$ .

Sample solution is

$$\hat{P}_{12} = \frac{\hat{H}_0 \hat{Q}_{12} (1 - \hat{Q}_{24})}{1 - G(z)}$$

where

$$G(z) = \hat{Q}_{24} \hat{Q}_{43} \hat{Q}_{32} + \hat{Q}_{12} \hat{Q}_{24} \hat{Q}_{41} + \hat{Q}_{12} \hat{Q}_{24} \hat{Q}_{43} \hat{Q}_{31}.$$

The eigen-vector solution for its embedded MC is

$$\begin{aligned} \underline{e} &= (e_1, e_2, e_3, e_4) \\ &= \left( \frac{1-q^{k+m}}{c}, \frac{1}{c}, \frac{q^m}{c}, \frac{1}{c} \right) \end{aligned}$$

where  $c = 3 + q^m(1-q^k)$ .

Other plans, like the multi level ones, feature phases of the type already met but with different sampling parameters for the same types; for example,  $ls(k_1, f_1)$ ,  $ls(k_2, f_2)$ , etc.

5.0 ARBITRARY ENTRY CASE. In elementary (continuous) renewal theory, the introduction of a delayed p.d.f. is necessary for dealing with the equilibrium case. If  $F(x)$  is the distribution function of the ordinary process,  $\mu$  the (long-run) mean time between renewals,  $f(x)$  the delayed p.d.f., and  $m_e(x)$  the mean number of renewals in time  $x$  for the equilibrium process, it can be shown [Ref 7.8] that

$$f(x) = \frac{1}{\mu} (1-F(x))$$

and

$$m_e(x) = \frac{x}{\mu} .$$

In Cinlar's paper [Ref 7.6], analogous results are also shown to hold.

Following Cinlar [Ref 7.6, Chp 9], with modifications for the discrete time case, we have on the one hand

Definition 1. Letting  $\tilde{Q}_{i,j}(t)$  be the delayed p.d.f., we have

$$\tilde{Q}_{i,j}(t) = \frac{1}{\mu_i} H_1^*((q_{i,j}) \delta_0 - Q_{i,j})(t)$$

On the other hand, for the Arbitrary Entry case of a MC model of a CSP, using either the MC or SMC methods, the initial probability vector for a given phase  $i$  is now given, overtly dependent on the structure of the entire MC, by

$$\underline{w}_i = \left( \frac{\alpha_1}{\alpha_i}, \dots, \frac{\alpha_s}{\alpha_i}, \dots \right), s \in i$$

where  $\alpha_i$  is the long-run probability for SMC state  $i$  and  $\alpha_s$  is the analogous long run probability for SMC state  $s$  which arises from that filtration of the primitive SMC which forbids SMC-state self-transitions. Thus, we can also define a delayed p.d.f. as in

Definition 2. Letting  $\bar{Q}_{i,j}$  be the delayed p.d.f.; then we define it as

$$\bar{Q}_{i,j}(t) = \sum_{s \in i} \frac{\alpha_s}{\alpha_i} f_{s,A(j)}^t,$$

where, once again,  $f_{s,A(j)}^t$  is the first entrance probability (at time  $t$ ) into phase  $j$  starting initially from state  $s$  in phase  $i$  with probability  $\alpha_s/\alpha_i$ .

Two points concerning Definition 2 should be made. In contrast to the J-S case,  $w_i$  is "used just once" since any jump to  $j$  returns the process to the J-S case. Secondly, even though  $w_i$  appears to be plan dependent, it is shown later in this chapter that it is not; intuitively this is reasonable since  $\alpha_s/\alpha_i$  can be interpreted as the relative time spent in phase  $i$  starting from  $s$ .

Below a. the  $\bar{Q}_{i,j}$ 's are constructed for all canonical phases considered in the J-S case; b. definitions one and two are proven equivalent by elucidating the relationships between the primitive SMC and any filtration of it (thereby showing  $w_i$  to be plan independent); c. any SMC (or MRP) is shown to be stationary if its initial p.d.f.'s are given by Definition one; and d. the steady state SMC is derived for CSP-1 and a bound on the variance of  $FI(N)$  is obtained.

5.1 Definition equivalence. Extensions of the techniques used here to include variations from the four standard phases are straight-forward. In Theorems one through four below,  $\hat{f}_{s,A}$  shall have the meaning assigned to it by Definition 2.

Theorem 1. Definition equivalence for sc.

Proof. a. Again letting  $HK=K$ , we have from the basic MC system for sc,

$$\hat{f}_{k,A} = q^{I-k} \frac{(z-q)}{\phi(z)} (z^k - pz^{k-1} - pqz^{k-2} - \dots - pq^{k-1})$$

$$= q^{I-k} \frac{\phi_k(z)}{\phi(z)}$$

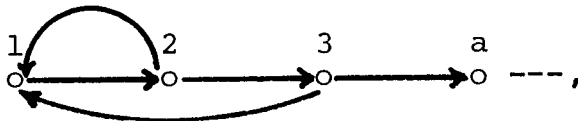
where

$$\phi_k(z) = z^k(z-1) + \gamma_k, \quad \gamma_k = pq^k,$$

and

$$\phi(z) = \phi_I(z).$$

b. We now proceed to split  $sc$  into three consecutive subphases:  $sc(k)$ ,  $H(k)$ , and  $R(k)$ . Thus, letting  $1 = sc(k)$ ,  $2 = H(k)$ , and  $3 = R(k)$  for simplicity, we have:



where  $a$  is the next state of the plan. This splitting yields the following transitional matrix for the embedded MC obtained from this variant SMC:

$$\begin{array}{c} 1 \\ 2 \\ 3 \\ a \\ - \\ - \\ - \end{array} \begin{bmatrix} & 1 & 2 & 3 & a & \dots \\ \begin{bmatrix} 0 & 1 & 0 & 0 & \dots & 0 \\ p & 0 & q & 0 & \dots & 0 \\ 1-q^r & 0 & 0 & q^r & \dots & 0 \\ * & - & - & * & & * \\ - & - & - & - & & - \\ - & 0 & 0 & - & & - \end{bmatrix} & = T' \end{bmatrix}$$

where  $r = I-(k+1)$ . Letting  $\underline{e}' = (e'_1, e'_2, e'_3, e'_a, \dots)$ , we obtain the eigen vector equation

$$\underline{e}'T' = \underline{e}'.$$

This equation in turn leads to the following algebraic system:

$$\left. \begin{array}{l} Pe'_2 + (1-q^r)e'_3 + v = e'_1 \\ e'_1 = e'_2 \\ qe'_2 = e'_3 \\ q^r e'_3 + u = e'_a \end{array} \right\} (E_0)$$



where  $v = \underline{e}' \cdot \underline{col}_1'$ ,  $u = \underline{e}' \cdot \underline{col}_4'$ , and  $\underline{col}_i'$  is obtained from the  $i^{\text{th}}$  column vector by setting its first three components equal to zero; the rest of the induced algebraic system is the same as the one gotten from the original SMC.

c. From Theorem 3.1 and Corollary 1 to Theorem 3.6, we have for the mean values of SMC states 1, 2, and 3

$$\mu_1 = \frac{1-q^k}{pq^k}, \quad \mu_2 = 1, \quad \text{and} \quad \mu_3 = \frac{1-q^r}{p}.$$

d. From b., c., and Theorem 2.4,

$$\alpha_s = \frac{e_s' \mu_s}{D'} \quad (s = 1, 2, \text{ and } 3),$$

$$\begin{aligned} D' &= \sum_{s=1,2,3} e_s' \mu_s + \sum_{\text{other}} e_s \mu_s \\ &= D_1 + D_2 \end{aligned}$$

where, by  $(E_0)$  in b. and c.,

$$\begin{aligned} D_1 &= e_1' \left( \frac{1-q^k}{pq^k} \right) + e_1' + (qe_1') \frac{1-q^r}{p} \\ &= e_1' \left( \frac{1-q^I}{pq^I} \right) q^{I-k} \\ &= e_1' \mu_{sc} q^{I-k} \quad (E_0'). \end{aligned}$$

e. Returning to the original SMC, we now consider the transitional matrix for its embedded MC:

$$\begin{array}{c} \text{sc} \\ \text{a} \\ \cdot \\ \cdot \\ \cdot \end{array} \begin{bmatrix} & \text{sc} & \text{a} & \dots \\ \text{sc} & 0 & 1 & \\ \text{a} & * & * & * \\ \cdot & & & \\ \cdot & & & \\ \cdot & & & \end{bmatrix} = T$$

This matrix induces the following linear system via  $\underline{e}^T = \underline{e}$ :

$$\left. \begin{array}{l} v = e_{sc} \\ e_{sc} + u = e_a \end{array} \right\} \Rightarrow \left\{ \begin{array}{l} v = e_{sc} \\ u = e_a - e_{sc} \end{array} \right. (E_1),$$

where  $v = \underline{e} \cdot \underline{col}_{sc}$ ,  $u = \underline{e} \cdot \underline{col}_a$ ,  $\underline{col}_a$  is obtained from  $\underline{col}_a$  by setting its first component equal to zero. However from  $(E_0)$ , we also have

$$\left. \begin{array}{l} u = e'_a - q^{I-k} e'_1 \\ v = q^{I-k} e'_1 \end{array} \right\} (E_2)$$

Therefore from  $(E_1)$  and  $(E_2)$ , we have

$$\left. \begin{array}{l} e_{sc} = q^{I-k} e'_1 \\ (e_a = e'_a) \end{array} \right\} (E_3)$$

(We also know that  $e_j = e'_j$  for  $j \neq (1, 2, 3)$ ).

f. Therefore, from  $(E_0)$  and  $(E_3)$ , we get

$$D_1 = e_{sc} \mu_{sc} \xrightarrow{\quad} D' = D.$$

Thus finally from d. and the above,

$$\alpha_{H(k)} = \frac{e_{sc} q^{k-I}}{D}$$

or

$$\alpha_{H(k)} = \left( \frac{1}{\mu_{sc}} \right) (q^{k-I}) \alpha_{sc} ;$$

As a check, we have  $\sum_0^{I-1} \alpha_{H(k)} = \alpha_{sc}$ .

g. From a. and f., we have

$$\frac{\alpha_{H(k)}}{\alpha_{sc}} \hat{f}_{k,A} = \frac{1}{\mu_{sc}} \frac{\theta_k(z)}{\theta(z)}$$

h. Since

$$\begin{aligned} \sum_{k=0}^{I-1} \vartheta_k(z) &= z \left( \sum_0^{I-1} z^k \right) - \left( \sum_0^{I-1} z^k \right) + (1-q^I) \\ &= \left( \frac{1}{z-1} \right) (z^I(z-1) - q^I(z-1)), \end{aligned}$$

we have with g.,

$$\begin{aligned} \sum_{k=0}^{I-1} \frac{\alpha_k}{\alpha_{sc}} \hat{f}_{k,A} &= \frac{\hat{H}_1}{\mu_{sc}} \left\{ \frac{z^I(z-1) - q^I(z-1)}{\vartheta(z)} \right\} \\ &= \frac{\hat{H}_1}{\mu_{sc}} \left\{ 1 - \frac{q^I(z-q)}{\vartheta(z)} \right\}. \end{aligned}$$

The proof is finished by noting that  $\hat{Q}_{sc,A}(1) = 1$  and  $q^I(z-q)/\vartheta(z) = \hat{Q}_{sc,A}(z)$ .

Theorem 2. Definition equivalence for uls phase

Proof.

a. From Theorem 2.4,

$$\left. \begin{aligned} vP_{a,uls}(t) &= P_{a,SN}(t) \\ fP_{a,uls}(t) &= P_{a,SI}(t) \end{aligned} \right\} \Longrightarrow \begin{cases} \alpha_{SN} = v\alpha_{uls} \\ \alpha_{SI} = f\alpha_{uls} \end{cases}$$

$$b. \quad \frac{\alpha_{SN}}{\alpha_{uls}} \hat{f}_{SN,A} + \frac{\alpha_{SI}}{\alpha_{uls}} \hat{f}_{SI,A}$$

$$= v\hat{f}_{SN,A} + f\hat{f}_{SI,A}, \text{ from a.}$$

$$= \hat{f}_{uls,A}$$

$$\begin{aligned}
 \text{c. } \frac{\hat{H}_1}{\mu_{\text{uls}}} \left(1 - \frac{\delta}{z-\beta}\right) &= \left(\frac{\delta}{z-1}\right) \left(\frac{z-1}{z-\beta}\right) \\
 &= \frac{\delta}{z-\beta} \\
 &= \hat{f}_{\text{uls},A} ;
 \end{aligned}$$

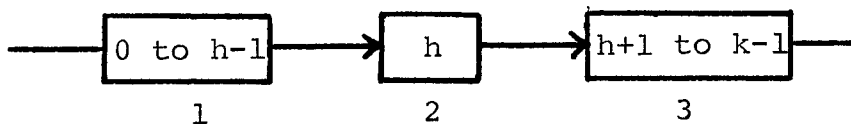
or

$$\frac{\hat{H}_1}{\mu_{\text{uls}}} (1 - \hat{Q}_{\text{uls},A}) = \hat{Q}_{\text{uls},A}$$

which, along with b., finishes the proof.

Theorem 3. Definition equivalence for ls phase

Proof. a. Break ls into (SN-SI) blocks as follows:



Since all the blocks are structurally equivalent, we have from Theorem 3.3,

$$\mu_1 = \frac{1-q^h}{fp}, \quad \mu_2 = \frac{1-q}{fp}, \quad \text{and} \quad \mu_3 = \frac{1-q^r}{fp} \quad (E_0)$$

where  $r = k - (h+1)$ .

b. In the split system, we can put the three segments of ls first in the corresponding transitional matrix of the embedded MC:

$$\begin{array}{c}
 1 \\
 2 \\
 3 \\
 a \\
 b \\
 \vdots \\
 \vdots \\
 \vdots
 \end{array}
 \begin{bmatrix}
 & 1 & 2 & 3 & a & b & \dots \\
 1 & 0 & q^h & 0 & & & \\
 2 & 0 & 0 & q & & & \\
 3 & 0 & 0 & 0 & & * & \\
 a & & \cdot & \cdot & & & \\
 b & * & \cdot & \cdot & & & \\
 \vdots & & \cdot & \cdot & & & \\
 \vdots & & \cdot & \cdot & & & \\
 \vdots & & 0 & 0 & & & 
 \end{bmatrix}
 = T'$$

Then  $\underline{e}'T' = \underline{e}'$  induces

$$\left. \begin{array}{l} v = e'_1 \\ q^h e'_1 = e'_2 \\ qe'_2 = e'_3 \end{array} \right\} (E_1)$$

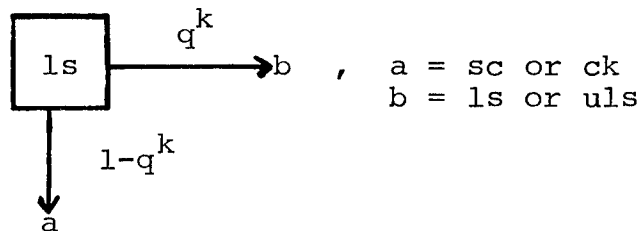
Therefore,  $\sum_{s=1}^3 e'_s \mu_s = \frac{e'_1}{fp} (1-q^k)$  from  $(E_0)$  and  $(E_1)$ .

Therefore,  $D_1 = e'_1 \mu_{1s}$  and hence

$$\alpha^{(h)} = \alpha_2 = \frac{(q^h/f)e'_1}{D_2 + e'_1 \mu_{1s}},$$

$$D_2 = \sum e'_j \mu_j, \quad j \neq (1,2,3).$$

c. In order to get the necessary relationships between the primed and unprimed systems, we need some additional conditions on exits and entrances; we assume the usual "CSP-2" type:



Using the above assumptions, we can now fill in the a and b columns of T :

$$\begin{array}{l} \begin{array}{ccc} 1 & 2 & 3 \\ a: (1-q^h, & 1-q, & 1-q^r, *)^t \\ b: (0, & 0, & q^r, *)^t \end{array} \end{array}$$

where  $\underline{y}^t$  is the transposed vector of  $\underline{y}$ . The resulting "augmented" matrix leads to the system  $(E_2)$ :

$$\left. \begin{array}{l} (1-q^h)e'_1 + pe'_2 + (1-q^r)e'_3 + u = e'_a \\ q^r e'_3 + w = e'_b \end{array} \right\} (E_2)$$

where  $u = \underline{e}' \cdot \underline{\text{col}}'_a$ ,  $w = \underline{e}' \cdot \underline{\text{col}}'_b$ , and  $\underline{\text{col}}'_(\cdot)$  is derived from  $\underline{\text{col}}(\cdot)$  by setting the first three components equal to zero. Then

$$(E_1) \text{ and } (E_2) \Rightarrow \left\{ \begin{array}{l} e'_a - u = e'_1(1-q^k) \\ e'_b - w = e'_1q^k \end{array} \right\} \quad (E_3)$$

d. The standard transitional matrix T is

$$\begin{array}{c} \text{ls} \\ \text{a} \\ \text{b} \\ \cdot \\ \cdot \\ \cdot \end{array} \begin{bmatrix} \text{ls} & \text{a} & \text{b} & \dots \\ 0 & 1-q^k & q^k & \dots \\ * & * & * & \dots \\ \cdot & \cdot & \cdot & \cdot \\ \cdot & \cdot & \cdot & \cdot \\ \cdot & \cdot & \cdot & \cdot \end{bmatrix}$$

From  $\underline{e}T = \underline{e}$ , we get

$$\left. \begin{array}{l} v = e_{1s} \\ (1-q^k)e_{1s} + u = e_a \\ q^k e_{1s} + w = e_b \end{array} \right\} \quad (E_4)$$

where  $v = \underline{e} \cdot \underline{\text{col}}_{1s}$ ,  $u = \underline{e} \cdot \underline{\text{col}}'_a$ ,  $w = \underline{e} \cdot \underline{\text{col}}'_b$ , and  $\underline{\text{col}}'_(\cdot)$  is gotten from  $\underline{\text{col}}(\cdot)$  by setting the first component equal to zero. Finally, from  $(E_2)$  and  $(E_4)$ , we get

$$\left. \begin{array}{l} e'_1 = v = e_{1s} \\ e'_a = e_a \\ e'_b = e_b \end{array} \right\} \quad (E_5)$$

e. Thus from  $(E_5)$  and the last part of b.,

$$\begin{aligned} \alpha_{(h)} &= \alpha_2 \\ &= \frac{(q^h/f)e_{1s}}{D} \end{aligned}$$

or

$$\alpha_{(h)} = \left(\frac{1}{\mu_{1s}}\right) \left(\frac{q}{f}\right)^h \alpha_{1s}.$$

f. As in Theorem 2,  $\alpha_{SNh} = v\alpha_h$  and  $\alpha_{SIh} = f\alpha_h$  which together imply that

$$\sum_{h=0}^{k-1} \frac{\alpha_{SNh}}{\alpha_{1s}} \hat{f}_{SNh,A} + \sum_{h=0}^{k-1} \frac{\alpha_{SIh}}{\alpha_{1s}} \hat{f}_{SIh,A} = \sum_h \frac{\alpha_h}{\alpha_{1s}} \hat{f}_{h,A}.$$

g. From e. and f.

$$\hat{f}_{h,A(1)}(z) = \left(\frac{fq}{z-v}\right)^{k-h}$$

$$\hat{f}_{h,A(1)}(z) = \left(\frac{\delta}{z-\beta}\right) \left(1 - \left(\frac{fq}{z-v}\right)^{k-h}\right)$$

Therefore, sum for A(2)

$$\begin{aligned} &= \frac{1}{f\mu_{1s}} \left\{ \sum_{h=0}^{k-1} q^h \left(\frac{z-v}{fq}\right)^h \right\} \left(\frac{fq}{z-v}\right)^k \\ &= \frac{1}{f\mu_{1s}} \left\{ \frac{1 - \left(\frac{z-v}{f}\right)^k}{f-z+v} \right\} \left(\frac{fq}{z-v}\right)^k \\ &= \frac{\hat{H}_1}{\mu_{1s}} \left\{ q^k - \left(\frac{fq}{z-v}\right)^k \right\}. \end{aligned}$$

h. Letting  $x = \delta/(z-\beta)$  and  $x' = (fq/(z-v))^k$ , and again using e. and f., the sum for A(1) is

$$\begin{aligned} &\sum_{h=0}^{k-1} \frac{\alpha_h}{\alpha_{1s}} \hat{f}_{h,A(1)} \\ &= \left(x - \frac{\hat{H}_1}{\mu_{1s}} (q^k - x')\right) x \\ &= \frac{\hat{H}_1}{\mu_{1s}} \left(\frac{\mu_{1s}}{\hat{H}_1} x - q^k x + xx' - x + x\right) \end{aligned}$$

$$\begin{aligned}
&= \frac{\hat{H}_1}{\mu_{1s}} \left( (1-q^k)(x) \left( \frac{z-1}{\delta} + 1 \right) - x + xx' \right) \\
&= \frac{\hat{H}_1}{\mu_{1s}} \{ (1-q^k) - x(1-x') \} \\
&= \frac{\hat{H}_1}{\mu_{1s}} \{ \hat{Q}_{1s,A(1)}(1) - \hat{Q}_{1s,A(1)}(z) \}
\end{aligned}$$

since  $((z-1)/\delta) + 1 = (z-\beta)/\delta = 1/x$  which finishes Theorem 3.

Theorem 4. Definition equivalence for ck phase.

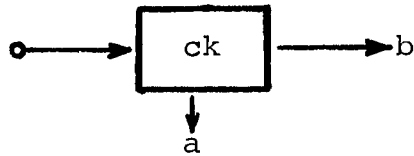
Proof. a. Splitting ck into its MC components and using induction along with the C-K equations, we have

$$\left. \begin{aligned}
\hat{f}_{Cj,A(b)} &= \left( \frac{q}{z} \right)^{m-j} \\
\hat{f}_{Cj,A(a)} &= \frac{1-q^{m-j}}{z^{m-j}}
\end{aligned} \right\} 0 \leq j \leq m-1$$

and

$$\hat{f}_{\bar{C}j,A(a)} = \frac{1}{z^{m-(j+1)}} \quad , \quad 0 \leq j \leq m-2$$

where a and b are defined through the following diagram:



b. The transitional matrix  $T'$  is too bulky to write down here, but we do order the states as:  $C_0, \dots, C_{m-1}, \bar{C}_0, \dots, \bar{C}_{m-2}, a, b, \dots$  in what follows. From the eigen-vector equation, we get



$$\left. \begin{array}{l} e'_0 = v \\ qe'_j = e'_{j+1} \\ 0 \leq j \leq m-2 \end{array} \right\} (E_0), \quad \left. \begin{array}{l} pe'_0 = \bar{e}'_0 \\ \bar{e}'_j + pe'_{j+1} = \bar{e}'_{j+1} \\ (0 \leq j \leq m-3) \end{array} \right\} (E_1),$$

$$\left. \begin{array}{l} e_a = u + e'_{m-1} + \bar{e}'_{m-2} \\ e_b = w + qe'_{m-1} \end{array} \right\} (E_2)$$

where  $e'_j = e'_{Cj}$ ,  $\bar{e}'_j = e'_{\bar{C}j}$ ,  $v = \underline{e}' \cdot \underline{\text{col}}_0$ ,  $u = \underline{e}' \cdot \underline{\text{col}}'_a$ ,  
 $w = \underline{e}' \cdot \underline{\text{col}}''_b$

$$(\underline{\text{col}}'_a)_j = \begin{cases} (\underline{\text{col}}_a)_j, & \text{if } j \neq m-1, m \\ 0, & \text{otherwise.} \end{cases}$$

and

$$(\underline{\text{col}}''_b)_j = \begin{cases} (\underline{\text{col}}_b)_j, & \text{if } j \neq m \\ 0, & \text{otherwise.} \end{cases}$$

From  $(E_0)$  and  $(E_1)$  we get

$$\left. \begin{array}{l} \bar{e}'_j = e'_0 (1 - e^{j+1}) \\ e'_j = e'_0 q^j \end{array} \right\} (E_3)$$

But now, again from Theorem 2.4,

$$\alpha_{\bar{C}j} = \frac{\bar{e}'_j}{D'} \quad \text{and} \quad \alpha_{Cj} = \frac{e'_j}{D'}$$

where

$$D' = \sum_0^{m-1} e'_k + \sum_0^{m-2} \bar{e}'_k.$$

Again,  $(E_3) \Rightarrow \left\{ \begin{array}{l} \sum_{k=0}^{m-1} e'_k = e'_0 \left[ \frac{1-q^m}{p} \right] \\ \sum_{k=0}^{m-2} \bar{e}'_k = e'_0 \left[ m - \left( \frac{1-q^m}{p} \right) \right] \end{array} \right.$

Therefore  $D' = me'_0$ .

c. From the transitional matrix of the original process, we get

$$\left. \begin{array}{l} v = e_{ck} \\ (1-q^m)e_{ck} + u = e_a \\ q^m e_{ck} + w = e_b \end{array} \right\} (E_4)$$

From  $(E_2)$  and  $(E_4)$ , we finally get

$$\left. \begin{array}{l} e'_0 = e_{ck} \\ e'_b = e_b \\ e'_a = e_a \end{array} \right\} (E_5)$$

d. Thus c. and b.  $\Rightarrow$

$$\alpha_{Cj} = \frac{(1-q^{1+j})}{\mu_{ck}} \alpha_{ck}$$

and

$$\alpha_{Cj} = \left( \frac{q^j}{\mu_{ck}} \right) \alpha_{ck}$$

e. From d. and a.,

$$\begin{aligned} \sum_{j=0}^{m-1} \frac{\alpha_{Cj}}{\alpha_{ck}} \hat{f}_{Cj, A(b)} &= \sum_{j=0}^{m-1} \frac{q^j}{\mu_{ck}} \left( \frac{q}{z} \right)^m \left( \frac{z}{q} \right)^j \\ &= \frac{1}{\mu_{ck}} \left( \frac{z^m - 1}{z - 1} \right) \left( \frac{q}{z} \right)^m \end{aligned}$$

$$= \frac{\hat{H}_1}{\mu_{ck}} (q^m - \hat{Q}_{ck, A(b)}(z))$$

$$(q^m = \hat{Q}_{ck, A(b)}(1)).$$

f. Once again using d. and a.,

$$\begin{aligned} & \sum_{j=0}^{m-1} \frac{\alpha_{cj}}{\alpha_{ck}} \hat{f}_{cj, A(a)} + \sum_{j=0}^{m-2} \frac{\alpha_{c\bar{j}}}{\alpha_{ck}} \hat{f}_{c\bar{j}, A(a)} \\ &= \sum_{j=0}^{m-1} \frac{q^j}{\mu_{ck}} \left( \frac{1-q^{m-j}}{z^{m-j}} \right) + \sum_{j=0}^{m-2} \frac{(1-q^{j+1})}{\mu_{ck}} \cdot \frac{1}{z^{m-(j+1)}} \\ &= \frac{1}{\mu_{ck} z^m} \left\{ \sum_0^{m-1} q^j z^j - q^m \sum_0^{m-1} z^j + \sum_0^{m-2} z^{j+1} - \sum_0^{m-2} (zq)^{j+1} \right\} \\ &= \frac{1}{\mu_{ck} z^m} \left\{ (1-q^m) + \sum_1^{m-1} (qz)^j - \sum_1^{m-1} (qz)^j + (1-q^m) \sum_1^{m-1} z^j \right\} \\ &= \frac{1}{\mu_{ck} z^m} (1-q^m) \left( \frac{z^m-1}{z-1} \right) \\ &= \frac{\hat{H}_1}{\mu_{ck}} \{ (1-q^m) - \hat{Q}_{ck, A(a)}(z) \}. \end{aligned}$$

Corollary (to Theorems 1-4)

$\alpha_s/\alpha_i$  is plan-independent.

Proof. (clear).

5.2 Equilibrium sampling plans. Having shown the equivalence of the two definitions in 5.0, we can now turn our attention to the fundamental SMC system for delayed p.d.f.'s ("v" and "—" have been replaced with a prime symbol). Since a first transition returns the equilibrium system to the ordinary non-delayed one, we have:

$$(F.S.): P'_{i,k}(t) = \sum_j Q'_{i,j} * P_{j,k}(t) + (\delta_{i,k}) J'_k(t)$$

where

$$\hat{J}'_k = \hat{H}_0 (1 - \hat{Q}'_k) .$$

For this system we have

Lemma.

$$\hat{J}'_k = \hat{H}_0 - \frac{\hat{H}_1}{\mu_k} \hat{J}'_k .$$

Proof.

$$a. \hat{J}'_k = \hat{H}_0 (1 - \sum_m \hat{Q}'_{k,m}) .$$

b. But,

$$\hat{Q}'_{km} = \frac{1}{z\mu_k} \hat{J}'_{k,m}$$

$$\sum_m \hat{Q}'_{k,m} = \frac{1}{z\mu_k} \hat{J}'_k .$$

c. Thus, since  $\hat{H}_0/z = \hat{H}_1$ , we are done by a. and b.

Theorem 5. (Stationarity) Given a CSP,

$\underline{\alpha} = (\alpha_1, \dots, \alpha_n)$  is a stationary distribution for  $P'_{i,j}(t)$ .

Proof.

a. Statement of Theorem is equivalent to

$$\sum_j \alpha_j P'_{j,k}(t) = \alpha_k, \quad (t \geq 0)$$

or

$$\sum_j \alpha_j \hat{P}'_{j,k} = \alpha_k \hat{H}_0 .$$

b. L.H.S. of last equation in a.

$$= \sum_j \sum_s \alpha_j \hat{Q}'_{j,s} \hat{P}_{s,k} + \alpha_k \hat{J}'_k$$

$$= W_1 + W_2, \text{ for (F.S.)}$$

$$c. W_1 = \sum_j \sum_s \frac{\alpha_j}{\mu_j} \hat{H}_1 (q_{j,s} - \hat{Q}_{j,s}) \hat{P}_{s,k}$$

$$= \sum_j \sum_s \frac{e_j}{D} \hat{H}_1 (q_{j,s} - \hat{Q}_{j,s}) \hat{P}_{s,k}$$

$$= \frac{\hat{H}_1}{D} \left\{ \sum_s \left\{ \sum_j e_j q_{js} \right\} \hat{P}_{sk} \right.$$

$$\left. - \sum_j e_j \left\{ \sum_s \hat{Q}_{js} \hat{P}_{sk} \right\} + (\sum e_j) (-e_k \hat{J}_k) + e_k \hat{J}_k \right\}$$

(the last two terms summing to zero since  $\sum e_j = 1$ )

$$= \frac{\hat{H}_1}{D} \left\{ \sum_s e_s \hat{P}_{sk} - \sum_j e_j \hat{P}_{jk} + e_k \hat{J}_k \right\}$$

$$= \frac{\hat{H}_1}{D} e_k \hat{J}_k$$

$$= \frac{\hat{H}_1}{\mu_k} \alpha_k \hat{J}_k .$$

d. By the lemma,

$$W_2 = \alpha_k \hat{J}'_k$$

$$= \alpha_k \left( \hat{H}_0 - \frac{\hat{H}_1}{\mu_k} \hat{J}_k \right)$$

e. c. and d.  $\implies$

$$W_1 + W_2 = \alpha_k \hat{H}_0$$

which completes the proof.

Defining  $M_k(t)$  as the number of recurrences of the state  $k$  in  $(0, t]$ , we have an analogous result concerning the stationarity of the renewal functions  $R'_{i,j}$ .

Theorem 6.

$$E_{\underline{\alpha}} [M_k(t)] = t \left( \frac{\alpha_k}{\mu_k} \right) .$$

Proof.

$$a. \quad E_{\underline{\alpha}} [M_k(t)] = \sum \alpha_i R'_{ik}(t) .$$

$$\text{Now } \hat{P}'_{ik} = \hat{R}'_{ik} (1 - \hat{Q}_k) + (\delta_{i,k}) \hat{J}'_k$$

$$\therefore \alpha_k \hat{H}_0 = \{ \sum \alpha_i \hat{R}'_{ik} \} (1 - \hat{Q}_k) + \alpha_k \hat{J}'_k$$

or

$$\frac{\alpha_k (\hat{H}_0 - \hat{J}'_k)}{1 - \hat{Q}_k} = \sum \alpha_i \hat{R}'_{ik} .$$

$$b. \quad \text{But } \hat{J}'_k = \hat{H}_0 - \hat{H}_0 \hat{Q}'_k$$

$$\begin{aligned} \therefore \hat{H}_0 - \hat{J}'_k &= \hat{H}_0 - \hat{H}_0 + \hat{H}_0 \hat{Q}'_k \\ &= \hat{H}_0 \hat{Q}'_k \\ &= \frac{\hat{H}_0 \hat{H}_1}{\mu_k} (1 - \hat{Q}_k) \end{aligned}$$

c. b. and a.  $\implies E_{\underline{\alpha}}[M_k(t)] = \hat{H}_0 \hat{H}_1 \left(\frac{\alpha_k}{\mu_k}\right)$ ; letting  $\hat{a}(z) = \hat{H}_0 \hat{H}_1$ , we have

$$a(n) = \int \frac{z^n dz}{(z-1)^2} = n$$

$$E_{\underline{\alpha}}[M_k(n)] = \left(\frac{\alpha_k}{\mu_k}\right)n.$$

5.3 Variance for CSP-1 and FI(N). We conclude this chapter with an application of Theorem 5 (and Theorems 1 through 4) in obtaining an upper bound to the second moment of (1-FI(N)) for CSP-1. To avoid repetition of Chapter 4, we split uls into its two nondegenerate subphases thereby dealing with a SMC with 3 states. Analogous methods can be applied to CSP-2 as well. Letting  $S(N) = 1-FI(N)$ , we have

$$E_{\underline{\alpha}}[(S(N))^2] = 2 \cdot \left\{ \begin{array}{l} \alpha_{SC} \frac{H_0 * P'_{SC,SN} * P_{SN,SN}(N)}{N^2} \\ + \\ \alpha_{SN} \frac{H_0 * P'_{SN,SN} * P_{SN,SN}(N)}{N^2} \\ + \\ \alpha_{SI} \frac{H_0 * P'_{SI,SN} * P_{SN,SN}(N)}{N^2} \\ - \frac{\alpha_{SN}}{N} \end{array} \right.$$

$$= 2W - \frac{\alpha_{SN}}{N}.$$

$$W = \frac{1}{N^2} \sum_{r=0}^N (\alpha_{SC} P'_{SC,SN} + \alpha_{SN} P'_{SN,SN} + \alpha_{SI} P'_{SI,SN}) * P_{SN,SN}(r)$$

$$= \frac{1}{N^2} \sum (\alpha_{SN} H_0) * P_{SN,SN}(r) *$$

\*This corrects formula 4.3E in reference 7.1.

$$\begin{aligned}
&= \alpha_{SN} \frac{(H_0^2 * P_{SN,SN}) (N)}{N^2} \\
&\leq \frac{1}{2} \alpha_{SN} \frac{H_0^2 (N)}{N} \left( \frac{H_0 * P_{SN,SN} (N)}{N} \right)
\end{aligned}$$

since  $H_0$  and  $H_0 * P_{SN,SN}$  are monotonically nondecreasing;

$$= \frac{1}{2} \alpha_{SN} \left( 1 + \frac{1}{N} \right) \left( \frac{H_0 * P_{SN,SN} (N)}{N} \right) .$$

Thus

$$E_{\alpha} [(S(N))^2] \leq \alpha_{SN} \left( 1 + \frac{1}{N} \right) \left( \frac{H_0 * P_{SN,SN} (N)}{N} \right) - \frac{\alpha_{SN}}{N} : (E_0)$$

$$\text{But } \hat{P}_{SN,SN} = \hat{Q}_{SN,SI} \hat{P}_{SI,SN} + \hat{J}_{SN}$$

$$\hat{P}_{SI,SN} = \hat{Q}_{SI,SN} \hat{P}_{SN,SN} + \hat{Q}_{SI,1} \hat{P}_{1,SN}$$

$$\hat{P}_{SN,SN} = \frac{\hat{Q}_{SN,SI} \hat{Q}_{SI,1} \hat{P}_{1,SN} + \hat{J}_{SN}}{(1 - \hat{Q}_{SN,SI} \hat{Q}_{SI,SN})}$$

$$= (\hat{Q}_{SN,SI} \hat{Q}_{SI,1} \hat{P}_{1,SN}) \hat{S} + \hat{J}_{SN} \hat{S}$$

$$= \hat{A} \hat{P}_{1,SN} + \hat{B} . \tag{E_1}$$

Now, simplifying

$$\hat{A}(z) = \frac{\delta}{z(z-\beta)}$$

which implies

$$H_0 * A(n) = \begin{cases} 1 - \beta^{(n-1)} & , n \geq 1 \\ 0 & , n = 0 \end{cases} \tag{E_2}$$

and

$$\hat{B}(z) = (z-fq)/(z-\beta)$$

which implies



$$H_0^*B(n) = 1 + \frac{v}{\delta} (1-\beta^n); \quad (E_3)$$

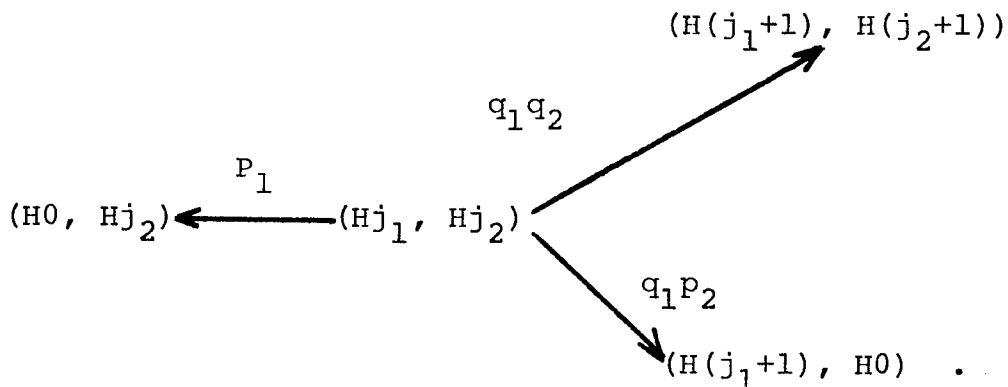
(E<sub>0</sub>), (E<sub>1</sub>), (E<sub>2</sub>), and (E<sub>3</sub>)  $\implies$

$$\begin{aligned} E_{\alpha} [(S(N))^2] &\leq \alpha_{SN} \left(1 + \frac{1}{N}\right) \left(\frac{H_0^*A^*P_{1,SN}(N)}{N} + \frac{H_0^*B(N)}{N}\right) - \frac{\alpha_{SN}}{N} \\ &\leq \alpha_{SN} \left(1 + \frac{1}{N}\right) \left\{ (H_0^*A(N)) \frac{(H_0^*P_{1,SN}(N))}{N} + \frac{H_0^*B(N)}{N} \right\} - \frac{\alpha_{SN}}{N} \\ &= \alpha_{SN} \left(1 + \frac{1}{N}\right) \left\{ (1-\beta^{N-1})(1-AFI(N)) + \frac{1}{N} \left(1 + \frac{v}{\delta} (1-\beta^N)\right) \right\} - \frac{\alpha_{SN}}{N} \end{aligned}$$

6.0 CONCLUDING REMARKS. We conclude this paper with two examples of the direct use of SMC theory followed by a short summary.

6.1 CSP-1 in tandem. Consider two CSP-1 plans arranged in tandem; i.e., the output of the first is the input of the second. This kind of sampling procedure (along with further iterations) can practically arise when each production unit is being inspected for 2 (or more) defects. An example of what is involved in a two dimensional MC model of this situation is now given.

For  $0 \leq j_1(j_2) \leq I_1 - 1(I_2 - 1)$ ,



Upon working out all the remaining transitional probabilities, it quickly becomes clear that such a model is time homogeneous.

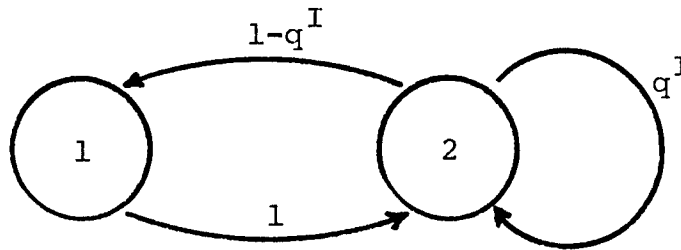
Let us now consider collapsing the two dimensional model into a one dimensional one; the result is non-Markovian (the reverse process, constructing a MC model out of a non-Markovian one through additional variables, thereby yielding higher dimensional states, is called the method of supplementary variables). Specifically, we obtain a non-homogeneous SMC; for instance, during the time interval  $(k, k+1)$ ,  $\bar{j} \rightarrow \bar{j}+1$  with probability

$$P_{\bar{j}, \bar{j}+1}(k, k+1) = (P_{11}(k)q_1 + P_{12}(k)\beta_1)q_2$$

where the first factor is derived from the first plan. However, if we consider the first CSP to be steady state, the result is a time homogeneous SMC: for instance,

$$Q_{\bar{j}, \bar{j}+1}(n) = \begin{cases} (P_1\alpha_1 + \delta_1\alpha_2)P_1^{n-2}q_1q_2, & n > 1 \\ (q_1\alpha_1 + \beta_1\alpha_2)q_2, & n = 1 \end{cases}$$

6.2 Downstream inspection. Another example of the direct use of SMC techniques is downstream inspection in a CSP-1 setting: if upon inspecting, a defect is found in the uls phase, go to an intermediate one and inspect, at 100%, the I previous units; if no defects are found, transfer back to uls; otherwise go to sc; then proceed as in CSP-1. This modified CSP-1 can be modeled directly with the following SMC without the intermediate stage; the model has the following SMC transitional diagram:



with

$$\alpha_{2,1}(n) = \beta^{n-1}(\delta)(1-q^I)$$

$$\alpha_{2,2}(n) = \beta^{n-1}(\delta)(q^I).$$

It should be noted that if sampling downstream were instead sampling upstream, we would essentially have a "partial" CSP-3 since operational time is measured by the flow of production units -- each counted once!

6.3 Summary. A simplified method, with some of its ramifications and variations, of dealing with the standard MC model of a given CSP has been considered. The essence of the technique is the partitioning of the MC into naturally defined segments. This blocking out of (relatively) many microstates into few (relatively) macrostates has been accomplished here within the natural context of SMC's. However, this approach does not obviate the need for the MC model in favor of some directly given SMC since the former is initially likely to be the more intuitive and easier of the two to construct. For a more practical explication on the basic method for the steady state case not explicitly involving SMC's, references 7.3 through 7.5 are highly recommended (where the method is called "A Simplified Markov Chain Approach").

## 7.0 REFERENCES.

7.1 Arp, D. L. "Expected values from a Markov Chain model of CSP-F and the Z-transform", Proceedings of the Nineteenth Conference on the Design of Experiments in Army Research Development and Testing, to be published.

- 7.2 Barrière, R. Optimal Control Theory, W. B. Saunders Co., Philadelphia, PA, 1967.
- 7.3 Brugger, R. M. "A simplification of the Markov chain approach to continuous sampling plan formulation", QEM 21-230-12, Ammunition Procurement and Supply Agency, 1972 (Transferred to US Army Armament Command; Rock Island, IL 61201).
- 7.4 Brugger, R. M. "Responsiveness properties of continuous sampling plans", Proceedings of the Nineteenth Conference on the Design of Experiments in Army Research Development and Testing, to be published.
- 7.5 Brugger, R. M. "Skip-lot procedure formulation using the simplified Markov chain method", Proceedings of the Twentieth Conference on the Design of Experiments in Army Research Development and Testing, to be published.
- 7.6 Cinlar, E. "Markov renewal theory", Adv. Appl. Prob., Vol 1 (1969), pp. 123-187.
- 7.7 Cinlar, E. "Periodicity in Markov renewal theory", AD 738-469.
- 7.8 Cox, D. R. Renewal Theory, Methuen Monographs on Applied Probability and Statistics, London, 1962.
- 7.9 Feller, W. "On Semi Markov Processes", Proc. of Nat'l Acad of Sci, Vol. 54 (1964), pp. 653-659.
- 7.10 Karlin, S. "On the renewal equation", Pacific J. Math., Vol. 5 (1955) pp. 229-257.
- 7.11 Pyke, R. "Markov renewal processes: definitions and preliminary properties", AD 227-271.
- 7.12 Pyke, R. "Markov renewal processes with finitely many states", AD 228-117.

## TRACKING RELIABILITY GROWTH

Larry H. Crow  
U. S. Army Materiel Systems Analysis Activity  
Aberdeen Proving Ground, Maryland

ABSTRACT. It is common practice for a complex system under development to be subjected to a test-fix-test-fix process. During this process, the system is tested until a failure occurs, design and/or engineering modifications are then made as attempts to eliminate the failure mode(s) and the system is tested again. This process is continued until the desired reliability is attained. Because of these changes in reliability and the fact that test data may be limited in quantity, it is often a difficult task to directly estimate the growth of reliability and relate this to the final reliability goal.

A popular, "common sense" procedure used for the tracking of reliability is not satisfying because of several major drawbacks. This paper gives improved, yet simple, techniques for tracking the system reliability through this development process, along with appropriate confidence bound and goodness of fit procedures. Application of these techniques to an Army system is discussed.

### 1. INTRODUCTION

Invariably, development programs for sophisticated, complex systems require considerable resources such as time, dollars and manpower, to achieve a level of system reliability acceptable to the user. The reliability requirements for many systems are high, and to obtain these high goals it is common practice to subject the system to a test-fix-test-fix process. During this process, the total system or major subsystems are tested to failure, system failure modes are determined, and design and/or engineering changes are made as attempts to eliminate these modes or, at least, to decrease their rate of occurrence. If this process is continued, and design and engineering modifications are made in a competent manner, then the system reliability will increase.

It is advantageous, of course, for the program manager to track this increase in system reliability during the development program. He may then determine as early as possible whether or not the system reliability is growing at a sufficient rate to meet the required goal and allocate available resources accordingly. In this regard, a program manager wishes to determine from test data the current reliability status of the system, estimate the rate of growth, and obtain projections of future expected reliability.

Since the system configuration is continually changing under this test-fix process, there is usually limited test data available on the system for a fixed configuration. Consequently, direct estimates of system reliability for a fixed configuration would generally not

enjoy a high degree of confidence and may, therefore, have little practical value.

Because of these difficulties with the direct estimation of system reliability, mathematical reliability growth models are often employed. Most reliability growth models considered in the literature assume that a mathematical formula (or curve), as a function of time, represents the reliability of the system during the development program. The central purpose of most reliability growth models includes one or both of the following objectives:

- a. Inference on the present system reliability,
- b. Projection on the system reliability at some future development time.

Many reliability growth models are parametric. That is, these models have certain parameters which are unknown and must be estimated from test data generated during the development program. This paper considers a popular parametric reliability growth model which is widely used in government and industry. Background on the derivation of the model will be discussed along with some major drawbacks with a "common sense" technique for estimating the unknown parameters. We show how these drawbacks can be avoided by applying estimation, goodness of fit and confidence interval procedures developed at AMSAA. Recently developed tables for computing exact confidence intervals on system failure rate and MTBF are given and an application of these techniques to an actual Army development program is discussed.

## 2. THE WEIBULL RELIABILITY GROWTH MODEL

In 1962, J. T. Duane of General Electric Company's Motor and Generator Department [see Duane (3)] published a report in which he presents his observations on failure data for five divergent types of systems during their development programs at G. E. These systems included complex hydromechanical devices, complex types of aircraft generators and an aircraft jet engine. The study of the failure data was conducted in an effort to determine if any systematic changes in reliability occurred during the development programs for these systems. His analysis revealed that for these systems, the observed cumulative failure rate versus cumulative operating hours fell close to a straight line when plotted on log-log paper. Similar plots have been noted in industry for other types of systems, and by the U. S. Army for various military weapon systems during development

[see Crow (2)].

For a mathematical interpretation of these straight line plots on log-log paper, let  $N(t)$  denote the number of system failures by time  $t$ ,  $t > 0$ . The observed cumulative failure rate  $C(t)$  at time  $t$  is, therefore, equal to  $C(t) = N(t)/t$ . The plots on log-log paper imply that  $\log C(t)$  is approximately a straight line. That is,  $\log C(t) = \delta + \gamma \log t$ . Equating  $C(t)$  to its expected value and assuming an exact linear relationship, we have  $\log (E[C(t)]) = \delta + \gamma \log t$ . Taking exponentials gives  $E[C(t)] = \lambda t^\gamma$ ,  $\lambda = e^\delta$ . Hence,  $E[N(t)] = \lambda t^\beta$ , for  $\beta = \gamma + 1$ , since  $E[C(t)] = E[N(t)]/t$ . Thus, the expected number of system failures by time  $t$  is  $\lambda t^\beta$ .

The instantaneous failure rate,  $r(t)$ , of the system is the change per unit time of  $E[N(t)]$ . Thus,  $r(t) = \frac{d}{dt} E[N(t)] = \lambda \beta t^{\beta-1}$ , which is recognized as being the Weibull failure rate function. It is important to note that since the system configuration is changing, the data are not homogeneous and, therefore, the usual theory for a Weibull distribution will not apply. In fact, it has been shown by the author [see Crow (1)] that when the configuration of the system is changing, and failures are governed by the failure rate  $r(t) = \lambda \beta t^{\beta-1}$ , then the system failure times follow a nonhomogeneous Poisson process with Weibull intensity function  $r(t)$ .

At time  $t_0$  the Weibull failure rate is  $r(t_0) = \lambda \beta t_0^{\beta-1}$ . If no further system improvements are made after time  $t_0$ , then it is reasonable to assume that the failure rate would remain constant at the value  $r(t_0)$  if testing were continued. In particular, if the system were put into production with the configuration fixed as it was at time  $t_0$ , then the life distribution of the systems produced would be exponential with mean time between failure (MTBF)  $M(t_0) = [r(t_0)]^{-1} = t_0^{1-\beta}/\lambda \beta$ . Hence, for  $0 < \beta < 1$ , the MTBF  $M(t)$  increases as the development testing time  $t$  increases, and is proportional to  $t^{1-\beta}$ . Thus,  $\beta$  is a growth parameter reflecting the rate at which reliability, or MTBF, increases with development testing time.

If this Weibull model is determined to sufficiently represent the occurrence of failures for a particular system during development testing, then it can, of course, be used to monitor and

project the growth of system reliability. To do this, however, would require estimating from test data the two unknown parameters  $\lambda$  and  $\beta$  by say  $\tilde{\lambda}$ ,  $\tilde{\beta}$ . One would then estimate the failure rate function by  $\tilde{r}(t) = \tilde{\lambda}\tilde{\beta}t^{\tilde{\beta}-1}$  and the MTBF function by  $\tilde{M}(t) = [\tilde{r}(t)]^{-1} = t^{1-\tilde{\beta}}/\tilde{\lambda}\tilde{\beta}$ . If the system is tested to time  $T$ , say, then  $\tilde{M}(T)$  would estimate the current MTBF, and  $\tilde{M}(t)$ ,  $t > T$  would project estimates of system MTBF into the future.

Consider a "common sense," often used procedure for estimating  $\lambda$  and  $\beta$ . Suppose the system is tested to time  $T$ , and let  $0 < T_1 < T_2 < \dots < T_K = T$  be a partition of  $(0, T]$ . The observed cumulative failure rate at time  $T_i$  is  $C(T_i) = N(T_i)/T_i$ , where  $N(T_i)$  is the number of system failures to time  $T_i$ ,  $i = 1, \dots, K$ . Recall that  $\log E[C(T_i)] = \log \lambda + (\beta-1)\log T_i$ . Hence, if we plot  $\log C(T_i)$  versus  $\log T_i$  on coordinate paper and fit a line by linear regression, we could use  $\gamma$ , the slope, to estimate  $\beta-1$  and  $\delta$  the intercept at  $t = 1$  to estimate  $\log \lambda$ . The estimates of  $\lambda$  and  $\beta$  would be  $\tilde{\lambda} = e^{\tilde{\delta}}$ ,  $\tilde{\beta} = \tilde{\gamma} + 1$ , respectively.

There are several points to be made about the above techniques for estimating  $\lambda$  and  $\beta$ . Firstly, the estimates are dependent on the choice of  $T_i$ ,  $i = 1, \dots, K$ , and, of course, may differ for different choices. Thus, this method is subjective, yielding results perhaps not susceptible to rigorous analysis. Secondly, the values  $C(T_i)$ ,  $i = 1, \dots, K$  are not independent since  $N(T_i) \leq N(T_j)$  for  $i < j$ . Moreover, the variances of the  $C(T_i)$ 's are not equal. In particular,  $\text{Var}[C(T_i)] = \lambda T_i^{\beta-2}$ . If the system reliability is improving ( $0 < \beta < 1$ ), then  $\text{Var}[C(T_i)]$  is decreasing as  $T_i$  increases. Hence, since the  $C(T_i)$ 's are not independent with equal variances, usual normal regression theory will not apply to yield confidence bounds on the parameters  $\lambda$ ,  $\beta$ , and the functions  $r(t)$ ,  $M(t)$ . Finally, in practice, the criteria for using the Weibull model and this estimation technique would probably depend on the subjective appraisal of whether or not the plotted points appear to lie nearly on a straight line.

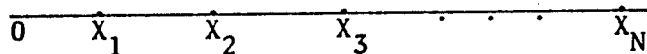


It is apparent that improved goodness of fit, estimation and confidence bound procedures are needed for this highly important task of monitoring and projecting the growth of system reliability during development. Using the result that the plots on log-log paper imply that the successive failure times of the system follow a certain stochastic process (i.e., the nonhomogeneous Poisson process with Weibull intensity  $\lambda\beta t^{\beta-1}$ ) we have derived a variety of useful statistical procedures for this model. Some recent results will be discussed in the following sections.

### 3. ESTIMATION AND GOODNESS OF FIT PROCEDURES

If the successive times of failures are being recorded for a system undergoing development testing, then a statistical goodness of fit test can be performed to determine if the Weibull reliability growth model is appropriate. If the model is acceptable, then closed form maximum likelihood (ML) estimates of  $\lambda$  and  $\beta$  may be used to estimate and project system MTBF. Using these procedures developed by the author in (1), one can avoid the aforementioned drawbacks associated with estimation from log-log plots.

Suppose that a system has experienced  $N$  failures during development testing. Let  $X_i$  be the age (time on test) of the system at the  $i$ -th failure  $i = 1, \dots, N$ . If testing is stopped at the  $N$ -th failure time, the data are said to be failure truncated.



The ML estimate of  $\beta$ , the growth parameter, is

$$(3.1) \quad \hat{\beta} = \frac{N}{N-1 \sum_{i=1}^{N-1} \log \frac{X_N}{X_i}}$$

and the ML estimate of  $\lambda$  is

$$(3.2) \quad \hat{\lambda} = \frac{N}{X_N^{\hat{\beta}}}$$

Thus, calculating  $\hat{\lambda}$ ,  $\hat{\beta}$  one may estimate the failure rate function  $r(t) = \lambda\beta t^{\beta-1}$  by  $\hat{r}(t) = \hat{\lambda}\hat{\beta}t^{\hat{\beta}-1}$ . The MTBF function  $M(t) =$

$[r(t)]^{-1}$  is similarly estimated by  $\hat{M}(t) = [\hat{r}(t)]^{-1}$ . In particular, the current estimate of the MTBF is  $\hat{M}(X_N) = X_N/N\hat{\beta}$ , and  $\hat{M}(t)$ ,  $t > X_N$ , projects expected future growth of system MTBF.

To determine the appropriateness of the Weibull model for representing the reliability growth for this system, one may calculate the statistic

$$(3.3) \quad C_M^2 = \frac{1}{12M} + \sum_{i=1}^M \left[ \left( \frac{X_i}{X_N} \right)^{\bar{\beta}} - \frac{2i-1}{2M} \right]^2,$$

where  $M = N - 1$ ,  $\bar{\beta} = [(M-1)/N]\hat{\beta}$ . Critical values of the  $C_M^2$  statistic for  $M = 2$  thru 60 have been determined at AMSAA from Monte Carlo simulation, using 15,000 samples for each value of  $M$ . Various critical values are given in Table 2 of (1).

If the statistic  $C_M^2$  is greater than the selected critical value, then the Weibull model is rejected at the designated significance level. If  $C_M^2$  is less than this critical value, then the Weibull model is accepted and may be used to track the system reliability growth.

Suppose that  $K \geq 1$  systems have been simultaneously tested to time  $T$ , where  $T$  is not a failure time. In this case the data are time truncated. If design and engineering modifications are made on all  $K$  systems at the same time, then at any time during the testing the systems will have basically the same configuration. In this situation, we may combine the failure data on these  $K$  systems to obtain estimates of  $\lambda$  and  $\beta$ . These estimates and other related procedures are given in (2).

#### 4. CONFIDENCE BOUNDS FOR MTBF

In this section we shall give recently developed procedures for placing confidence bounds on current and projected failure rates and MTBF. These procedures apply to the single system, failure truncated situation. Similar developments for time truncated testing will appear in a future AMSAA report when completed.

If a system undergoes development testing until the  $N$ -th

failure occurs, then  $r(X_N)$   $[M(X_N)]$  is the current failure rate [MTBF]. It can be shown that the ratio  $U_N = Nr(X_N)/(N-1)\hat{r}(X_N)$  is distributed independently of  $\lambda$  and  $\beta$ , where  $\hat{r}(X_N)$  is the ML estimate  $\hat{\lambda}\hat{\beta}X_N^{\hat{\beta}-1}$  of  $r(X_N)$ . Percentage points of this ratio were obtained at AMSAA from Monte Carlo simulation for  $N = 2$  thru 60. These percentage points are presented in Table 1. Exact  $100(1-\alpha)$  percent confidence bounds on  $r(X_N)$  are of the form  $[\hat{r}(X_N)a(N-1)/N, \hat{r}(X_N)b(N-1)/N]$ , where  $a$  and  $b$  are from Table 1 such that  $\text{Prob}(a < U_N < b) = 1-\alpha$ . Equivalently,  $100(1-\alpha)$  percent confidence bounds on  $M(X_N) = [r(X_N)]^{-1}$  are of the form  $([\hat{r}(X_N)b(N-1)/N]^{-1}, [\hat{r}(X_N)a(N-1)/N]^{-1})$ .

For  $N > 60$ ,  $100(1-\alpha)$  percent confidence bounds may be calculated from the approximate relationships:  $a \doteq 1 - \sqrt{2/N} Z_{\alpha/2}$ ,  $b \doteq 1 + \sqrt{2/N} Z_{\alpha/2}$ , where  $Z_{\alpha/2}$  is the  $\alpha/2$ -th percentile for the standard normal distribution.

For  $N$  moderately large, we may also use the percentage points in Table 1 to place approximate confidence bounds on future failure rates and MTBF. In particular, suppose we wish to place approximate  $100(1-\alpha)$  percent confidence bounds on  $r(T)$ ,  $T > X_N$ .

These approximate confidence bounds will again be of the form

$[\hat{r}(T)a(N-1)/N, \hat{r}(T)b(N-1)/N]$ , where  $\hat{r}(T) = \hat{\lambda}\hat{\beta}T^{\hat{\beta}-1}$  is the ML estimate of  $r(T)$ , and  $a$  and  $b$  are the appropriate percentage points from Table 1. Approximate  $100(1-\alpha)$  percent confidence bounds on  $M(T)$ , the MTBF at time  $T$ , are derived, as before, from the bounds on  $r(T)$ . These bounds become exact as  $N \rightarrow \infty$ .

## 5. NUMERICAL EXAMPLE

Suppose that a system undergoing development testing recorded the following 40 successive failure times; .7, 3.7, 13.2, 17.6, 54.5, 99.2, 112.2, 120.9, 151.0, 163.0, 174.5, 191.6, 282.8, 355.2, 486.3, 490.5, 513.3, 558.4, 678.1, 688.0, 785.9, 887.0, 1010.7, 1029.1, 1034.4, 1136.1, 1178.9, 1259.7, 1297.9, 1419.7, 1571.7, 1629.8, 1702.3, 1928.9, 2072.3, 2525.2, 2928.5, 3016.4, 3181.0, 3256.3. That is, the system was of age .7 when the first failure occurred, of age 3.7 when the second failure occurred, etc. At age

3256.3 the system had the 40-th failure. From these data, and equations (3.1) and (3.2) we find that  $\hat{\lambda} = 0.761$ ,  $\hat{\beta} = 0.490$ .

To determine if the Weibull model may be used to track this system's reliability growth, we calculate the goodness of fit statistic  $C_M^2$  given by equation (3.3) where  $M = 39$ ,  $\bar{\beta} = (38/40)\hat{\beta} = 0.465$ . This gives  $C_{39}^2 = 0.077$ . Next, we find in Table 2 of (1) that for  $M = 39$ , the critical value at the .05 significance level is 0.218. Since  $C_{39}^2 < 0.218$ , we accept the Weibull model.

Using  $\hat{\lambda}$ ,  $\hat{\beta}$ , the failure rate function is estimated by  $\hat{r}(t) = \hat{\lambda}\hat{\beta}t^{\hat{\beta}-1}$  and the MTBF function is estimated by  $\hat{M}(t) = [\hat{r}(t)]^{-1}$ . The current failure rate  $r(3256.3)$  is estimated to be  $\hat{r}(3256.3) = 0.006$ , and the estimate of current MTBF is  $[\hat{r}(3256.3)]^{-1} = 166.7$ .

To place 90 percent confidence bounds on the current MTBF  $M(3256.3)$ , we refer to Table 1,  $N = 40$ , and find  $a = 0.664$ ,  $b = 1.40$ . Using the formulas in the previous section, we get 90 percent confidence bounds (0.004, 0.008) for  $r(3256.3)$ . Hence, 90 percent confidence bounds on  $M(3256.3)$  are (125.0, 250.0).

Suppose we wish to place approximate 90 percent confidence bounds on future MTBF, say at  $T = 4000$ . Using  $\hat{r}(4000) = 0.005$ , we calculate these bounds to be (0.003, .007). Approximate confidence bounds on  $M(4000)$  are, therefore, (142.8, 333.3).

## 6. APPLICATION

In this section we shall discuss an application of the Weibull reliability growth procedures to an Army development program. Two major points concerning the application of this model are demonstrated. Firstly, the model may be applied to discrete data. Secondly, as in any mathematical model, care should be exercised in its use. In particular, the importance and usefulness of the goodness of fit statistic in Section 3 is demonstrated in this application.

Recently, AMSAA conducted a reliability growth study of a missile system. The purpose of the study was to use historic data on the first 801 valid flight tests to determine the growth curve, and

also to ascertain in retrospect how these data could have been used to track and project system reliability during development.

In reliability growth considerations, it is configuration changes on the system which are of prime importance. Consequently, in this study the 801 valid flights were ordered according to manufacturing date, since this should reflect the sequence and consequences of system configuration changes during development. The data consisted of the flight numbers at which a missile failure occurred. Observed that these are discrete data as opposed to continuous data in the model. However, it can be shown that for a large number of data points, the discrete failure process can be approximated by the continuous model. This approximation improves as the number of data points increases.

The interpretation of  $r(t)$  for this type of application is that  $r(i) = \lambda \beta i^{\beta-1}$  is the probability of failure for the  $i$ -th missile produced,  $i = 1, 2, \dots$ . Hence,  $R(i) = 1 - r(i)$  is the reliability of the  $i$ -th missile. Analogous to MTBF,  $M(i) = [r(i)]^{-1}$  is the mean flight between failure.

The first step in determining the reliability growth curve was to use the failure results for the 801 flights, and equations (3.1) and (3.2) to estimate the parameters of the Weibull model. The goodness of fit statistic  $C_M^2$ , given by equation (3.3), was then calculated to determine if the model and data were compatible. The value of the statistic was highly significant (very large) indicating that the model did not reasonably represent the data. This implies that a single, smooth, Weibull curve would not reflect the decrease in failure probability of this system.

Further investigation revealed that the development program experienced a major re-emphasis on reliability improvement after the 200-th flight. Thus, the parameters of the model were estimated separately for the first 200 flights (see Figure 1) and for the remaining 601 flights (see Figure 2). In both cases, the goodness of fit of the model to the data was acceptable. The horizontal lines in Figures 1 and 2 are the average failure probabilities over 100 flight intervals. The smooth curves are the estimated Weibull failure

probabilities  $\hat{\lambda} \hat{\beta} i^{\hat{\beta}-1}$ . These curves are solid up to the end of the data, and the dash lines indicate the estimated future decrease in failure probability if the current rate of improvement were continued.

From the two curves the reliability  $R(i) = 1-r(i)$  is estimated. The resulting reliability growth curve is shown in Figure 3 with a jump at 200. The magnitude of the jump was calculated by parametric and nonparametric means, and consultation with the program office.

We next considered how the Weibull model could have been used to track and project system reliability during development. Using the first 200 flights, the estimate of the current reliability was .68 and the projected reliability at flight 800 was .74 (Figure 1). This projection indicated that the system reliability requirement would not be met if the present trend were continued. There was a major re-emphasis on reliability, and based on the next 100 flights (201-300), an estimate of the reliability at 300 was .89 and a projection to 800 was .94 (Figure 4). This projection was very close to the current estimate of .95 for system reliability obtained using all the data on flights 201-800 (Figure 3).

Thus, the estimation procedures provided a good guide as to when additional emphasis should be placed on reliability, and also provided accurate estimates of future system reliability for each phase of the development program.

#### ACKNOWLEDGMENT

The author wishes to thank Mr. Edward F. Belbot for the computer programming which generated the Monte Carlo results of Table 1.

#### REFERENCES

1. L. H. Crow, Reliability Analysis For Complex, Repairable Systems, AMSAA Reliability, Availability and Maintainability Division Interim Note No. 26, January 1974.
2. L. H. Crow, On Reliability Growth Modeling, AMSAA Reliability, Availability and Maintainability Division Interim Note No. 27, January 1974.
3. J. T. Duane, Learning Curve Approach to Reliability Monitoring, IEEE Trans. Aerospace, Vol. 2, 1964.

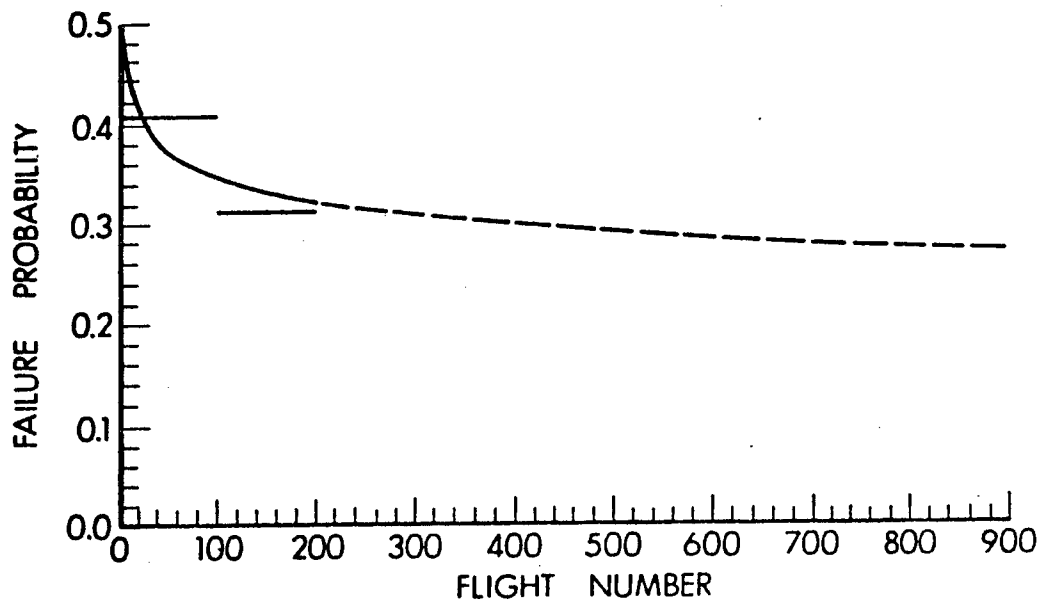


Figure 1. Estimate of Failure Probability for First 200 Valid Flights.

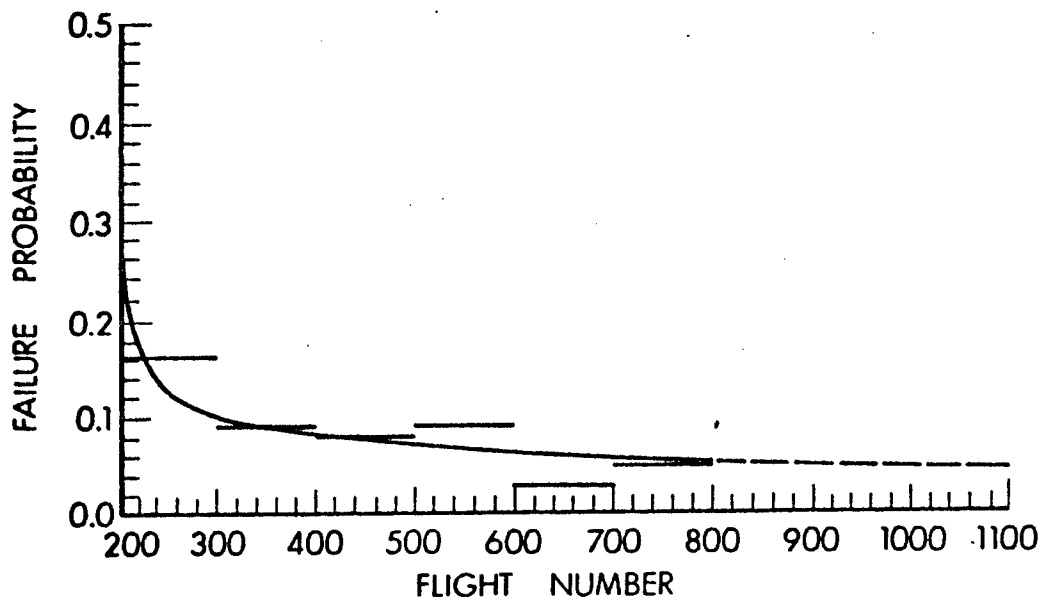


Figure 2. Estimate of Failure Probability Excluding First 200 Valid Flights.

N/P	25	50	10	20	30	40	50	60	70	80	90	95	97.5
2	.013	.027	.059	.135	.230	.353	.511	.725	1.03	1.49	2.44	3.59	4.95
3	.065	.099	.165	.282	.401	.540	.698	.888	1.14	1.51	2.21	2.94	3.70
4	.125	.168	.243	.375	.496	.631	.784	.958	1.17	1.48	2.02	2.57	3.13
5	.174	.227	.308	.438	.559	.682	.834	.984	1.17	1.44	1.90	2.37	2.85
6	.218	.274	.357	.487	.606	.723	.845	.991	1.17	1.41	1.82	2.21	2.61
7	.249	.312	.393	.521	.636	.749	.869	1.00	1.17	1.39	1.76	2.09	2.44
8	.285	.343	.427	.554	.663	.773	.887	1.01	1.17	1.37	1.70	2.01	2.31
9	.310	.373	.459	.582	.690	.792	.899	1.02	1.16	1.35	1.64	1.91	2.20
10	.336	.401	.486	.607	.709	.805	.908	1.02	1.16	1.34	1.62	1.89	2.15
11	.361	.422	.508	.627	.726	.821	.920	1.03	1.15	1.32	1.58	1.84	2.06
12	.379	.441	.527	.644	.740	.827	.923	1.03	1.15	1.31	1.55	1.79	2.01
13	.397	.456	.542	.659	.751	.842	.931	1.03	1.15	1.29	1.53	1.76	1.98
14	.420	.478	.559	.667	.759	.847	.936	1.03	1.15	1.29	1.52	1.73	1.94
15	.427	.489	.574	.681	.772	.855	.942	1.03	1.14	1.28	1.50	1.71	1.90
16	.442	.505	.586	.690	.780	.861	.946	1.03	1.14	1.27	1.49	1.68	1.87
17	.456	.519	.596	.699	.787	.867	.949	1.04	1.14	1.27	1.47	1.65	1.83
18	.466	.523	.600	.710	.794	.873	.953	1.04	1.14	1.26	1.45	1.64	1.80
19	.479	.538	.613	.715	.801	.881	.957	1.04	1.13	1.26	1.44	1.62	1.78
20	.490	.548	.623	.723	.804	.881	.957	1.04	1.13	1.25	1.43	1.61	1.77
21	.498	.561	.634	.733	.810	.883	.958	1.04	1.13	1.24	1.42	1.59	1.74
22	.509	.566	.641	.736	.813	.887	.959	1.04	1.12	1.24	1.41	1.57	1.71
23	.511	.574	.645	.742	.820	.892	.963	1.04	1.12	1.23	1.40	1.55	1.69
24	.522	.578	.651	.746	.823	.892	.963	1.04	1.12	1.23	1.40	1.54	1.68
25	.528	.586	.659	.754	.826	.897	.966	1.04	1.12	1.22	1.38	1.52	1.65
26	.530	.588	.660	.756	.831	.900	.967	1.04	1.12	1.22	1.38	1.52	1.65
27	.544	.594	.667	.760	.833	.901	.967	1.04	1.11	1.21	1.37	1.51	1.64
28	.544	.598	.672	.766	.839	.905	.969	1.04	1.11	1.21	1.36	1.49	1.62
29	.559	.615	.679	.772	.840	.905	.969	1.04	1.11	1.21	1.35	1.49	1.60
30	.559	.615	.682	.774	.845	.908	.971	1.04	1.11	1.21	1.35	1.47	1.59

Table 1. Percentage Points,  $u_p$ , such that  $\text{Prob}(U_N \leq u_p) = p$



N/P	2.5	5.0	10	20	30	40	50	60	70	80	90	95	97.5
31	566	621	691	774	846	909	971	1.04	1.11	1.20	1.34	1.47	1.58
32	574	625	691	780	847	911	972	1.04	1.11	1.20	1.33	1.45	1.57
33	580	632	696	784	851	911	972	1.03	1.11	1.20	1.33	1.45	1.57
34	584	638	704	789	855	914	973	1.03	1.11	1.19	1.32	1.44	1.56
35	585	642	707	790	856	914	975	1.03	1.11	1.19	1.32	1.43	1.53
36	595	645	710	792	857	914	975	1.03	1.11	1.19	1.32	1.43	1.53
37	599	652	712	796	861	920	977	1.03	1.10	1.19	1.31	1.42	1.53
38	599	656	717	800	863	920	978	1.03	1.10	1.19	1.31	1.42	1.51
39	606	659	722	803	866	924	978	1.03	1.10	1.18	1.30	1.41	1.51
40	614	664	725	805	868	925	978	1.03	1.10	1.18	1.30	1.40	1.49
41	615	670	729	807	869	925	978	1.03	1.10	1.18	1.29	1.39	1.49
42	619	670	731	810	872	926	978	1.03	1.10	1.18	1.29	1.39	1.48
43	624	675	734	812	872	926	978	1.03	1.10	1.18	1.29	1.39	1.48
44	624	675	737	816	874	927	978	1.03	1.09	1.17	1.29	1.39	1.48
45	633	681	741	818	875	928	980	1.03	1.09	1.17	1.28	1.38	1.46
46	634	682	741	818	877	930	981	1.03	1.09	1.17	1.28	1.38	1.46
47	636	685	745	819	878	930	981	1.03	1.09	1.17	1.27	1.37	1.46
48	641	691	746	819	879	930	981	1.03	1.09	1.16	1.27	1.37	1.46
49	642	691	751	824	880	933	982	1.03	1.09	1.16	1.27	1.35	1.44
50	642	694	753	827	883	934	983	1.03	1.09	1.16	1.27	1.36	1.44
51	649	697	753	827	885	936	984	1.03	1.09	1.16	1.26	1.35	1.44
52	650	697	754	829	885	936	984	1.03	1.09	1.16	1.26	1.35	1.44
53	652	699	759	831	886	936	984	1.03	1.09	1.16	1.26	1.35	1.44
54	655	704	760	833	888	938	985	1.03	1.09	1.16	1.26	1.34	1.43
55	660	706	762	835	889	938	985	1.03	1.09	1.16	1.25	1.34	1.42
56	659	706	764	837	890	939	985	1.03	1.09	1.15	1.25	1.34	1.42
57	666	712	767	837	890	939	985	1.03	1.09	1.15	1.25	1.34	1.41
58	664	712	769	839	892	939	985	1.03	1.09	1.15	1.25	1.33	1.41
59	668	716	771	839	893	939	985	1.03	1.09	1.15	1.25	1.33	1.41
60	673	719	771	840	893	939	985	1.03	1.09	1.15	1.25	1.33	1.41

Table 1. Percentage Points,  $u_p$ , such that  $\text{Prob}(U_N \leq u_p) = p$

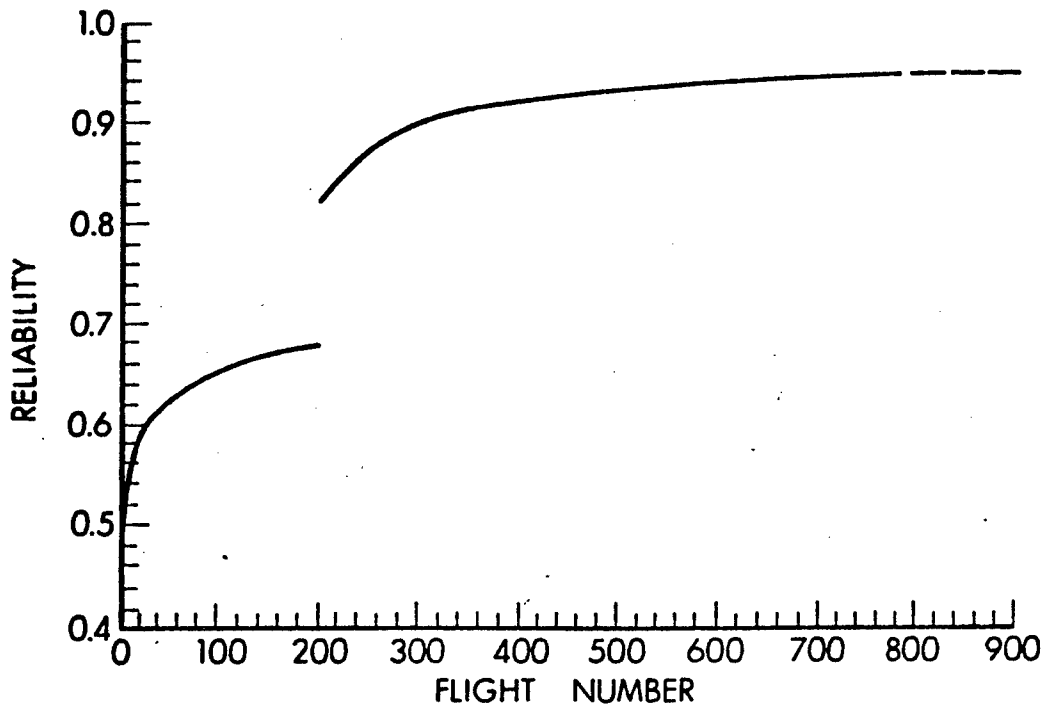


Figure 3. Estimated Reliability Based on Weibull Model.

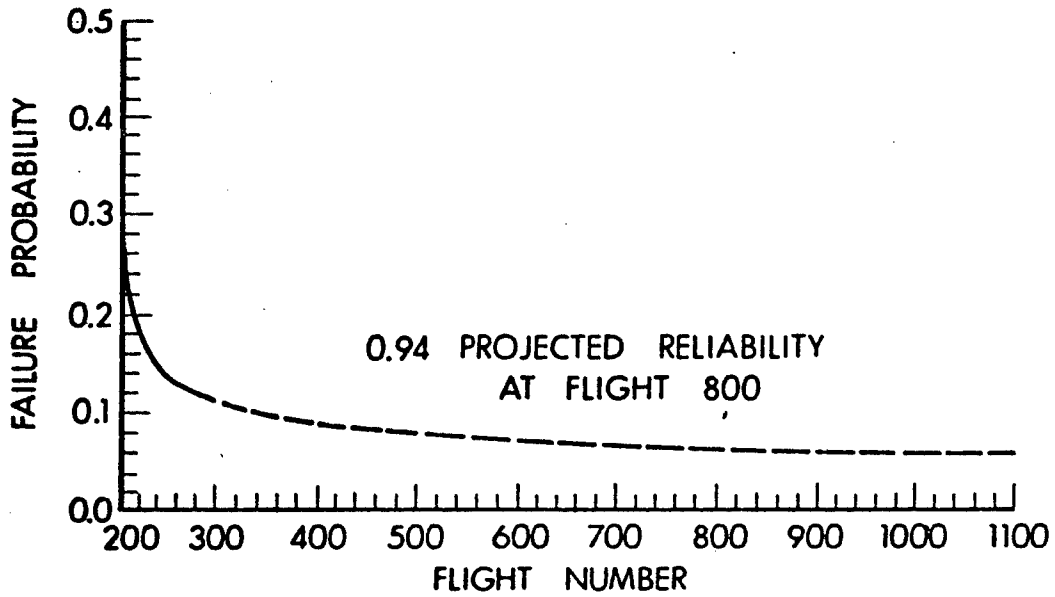


Figure 4. Projected Failure Probability Based on Flights 201 to 300.

MINIMUM VARIANCE SOLUTION OF A POLYNOMIAL FUNCTION  
OF TWO NOISY RANDOM VARIABLES

Oren N. Dalton  
Mathematical Services Branch  
Analysis and Computation Division  
White Sands Missile Range, New Mexico

ABSTRACT

The multivariate analysis problem involving two random vector variables, one a dependent and the other an independent variable, each variable noisy, has not been solved in general. However, if the two covariance matrices for the vector variables are independent and known, a maximum likelihood solution is possible in certain non-Euclidean spaces. This paper discusses an iterative technique for finding the minimum variance solution to a problem in which the independent variable is an  $m^{\text{th}}$  degree polynomial function of the independent variable, and both are normally distributed. The data is assumed to have high-noise content and to have been obtained, manually, from a graph using a ruler. Because of the nature of the data, problems of stability may arise. A method in which control of the excursions of the initial estimates of the polynomial coefficients by means of an ad hoc Bayesian covariance matrix, is included in the derivations, and a way to convert a divergent problem to a convergent problem by means of scaling is illustrated. The results for the minimum variance solution of a third-order polynomial math model, for mutually independent measurements using data from manual measurements from a graph, is included.

## I. INTRODUCTION.

We have the problem of estimating the parameters for a math model relating two random variables, each subject to noise. That is, let  $\xi_i$  and  $\eta_i$  represent two measurements:

$$\xi_i = x_i + \varepsilon_i$$

$$\eta_i = y_i + \delta_i$$

where  $\varepsilon_i$  and  $\delta_i$  represent noise, and such that

$$y_i = f(x_i) .$$

For the purpose of this paper, we assume that  $f(x_i)$  is an  $m^{\text{th}}$  degree polynomial. Thus, for any  $i$ :

$$y = p_0 + p_1x + p_2x^2 + \cdots + p_mx^m .$$

The problem as stated has not been solved in general [1], but if certain restrictions are assumed a minimum variance solution can be obtained. These restrictions are the independence criteria, well-known to practitioners of the art:

$$E\{\epsilon_i\} = E\{\delta_i\} = 0$$

$$\text{Cov}\{\epsilon_i, \epsilon_j\} = E\{\epsilon_i, \epsilon_j\} = \sigma_\epsilon^{ij}$$

$$\text{Cov}\{\delta_i, \delta_j\} = E\{\delta_i, \delta_j\} = \sigma_\delta^{ij}$$

$$\text{Cov}\{\epsilon_i, \delta_j\} = 0 ,$$

and the assumption that the  $\sigma_\epsilon^{ij}$  ,  $\sigma_\delta^{ij}$  are known. (This assumption can be relaxed [2], in that the variances can be estimated. It is assumed here, that such estimates, if necessary, have been made.)

For the polynomial in  $x$ , we note that if  $m=1$ , a fairly straight-forward derivation produces a quadratic equation for  $p_1$ , for example see [1,p. 258-60]. There are, however, several complications which may arise even in this simple case which are enumerated in considerable detail by Worthing and Geffner [3, pp. 375-91]. Additional difficulties arise when  $m>1$ , and a short discussion of some of these problems are also discussed by Worthing and Geffner [3,pp. 409-13], based mainly on the work of Geary [4].

On the other hand, it was shown [5] that most distributions commonly used can be classified in less than half-a-dozen equivalence classes described by non-Euclidean spaces, to the limit of a parameter; anything true for one member of the class is true for other members, or is true elements in spaces derivable from such spaces. Thus, the non-Euclidean space described as the " $\alpha$ -log" space includes such distributions as the Chi-squared, Maxwell, Gamma, Rayleigh and Normal; the pariminsic spaces derivable from this include the Beta, Student-t and Fisher (F); the derivable Uniform space includes the Uniform,

## Exponential or Poisson, Logistic and Cauchy.

The exposition in this paper is concerned with Normal variates, but from the above statements, it can be shown by extension [5] and [6], that the results are applicable to any of the other distributions. (Order statistics, since the range of the distribution depends on the variates, are, perforce, ruled out.)

### II. NOMENCLATURE AND DEFINITIONS.

1. A vector will be represented as:

a.  $\vec{x}$

b. The Dirac bra " $\langle$ " and ket " $\rangle$ " will only indicate row, column vectors resp. Functions involving these symbols have no other implication than standard matrix operations. Thus, for  $A$ , a matrix,  $\langle xAy \rangle$  is a bilinear form for vectors  $\vec{x}$  and  $\vec{y}$ .

2.  $f(\vec{x})$  represents a functional of the variables in the vector,  $\vec{x}$ .

3. Matrices or vectors may be defined as arrays whose elements are, themselves, arrays. Thus:

$$A = \begin{bmatrix} A_1 > & & & \phi \\ & A_2 > & & \\ & & \cdot & \\ \phi & & & \cdot \\ & & & A_m > \end{bmatrix}$$

represents an  $m \times m$  array, each of whose elements is a vector. If each  $A_i$  has  $k_i$  elements and if  $\sum_{i=1}^m k_i = k$ , then the total size of  $A$  in terms of scalar quantities is, perforce,  $mk \times m$ .

4.  $|A|$  represents the absolute value of the determinant of a matrix,  $A$ .

5.  $\phi >$ ,  $\phi$  represent a vector or matrix of zeros, resp. Subscripts if applicable, will indicate dimension.

6.  $I$  or  $I_n$  represent unit matrices; the dimension is specified in the 2<sup>nd</sup> case.

7. Some operators

a.  $\Gamma(\vec{x})$  indicates the diagonal matrix whose diagonal elements are the components of  $\vec{x}$ . Thus, if

$$x > = \begin{bmatrix} x_1 \\ x_2 \\ \cdot \\ \cdot \\ x_n \end{bmatrix}$$

then

$$\Gamma(\vec{x}) = \begin{bmatrix} x_1 & & & & \\ & x_2 & & & \\ & & \cdot & & \\ & & & \cdot & \\ & & & & x_n \end{bmatrix}$$

b.  $\langle D_k(x) \rangle$  is the vector for the  $k^{\text{th}}$  derivative of the polynomial in  $x$ . (Note:  $\langle D_k(x_0) \rangle$  implies the  $k^{\text{th}}$  derivative vector of  $x$  evaluated at  $x_0$ .) Thus:

$$1) \quad \langle D_0(x) \rangle = [1 \quad x \quad x^2 \quad \dots \quad x^m]$$

$$2) \quad \langle D_1(x) \rangle = [0 \quad 1 \quad 2x \quad \dots \quad mx^{m-1}]$$

Etc

c.  $D_k(\vec{x})$  is the matrix, each of whose rows is the  $k^{\text{th}}$  derivative of the corresponding component of  $\vec{x}$ . Thus:

$$D_k(\vec{x}) = \begin{bmatrix} \langle D_k(x_1) \rangle \\ \langle D_k(x_2) \rangle \\ \cdot \\ \cdot \\ \langle D_k(x_n) \rangle \end{bmatrix}$$

( $D_k(x_0)$ ) is defined similarly to that in "c", above.)

### III. THE PROBLEM DEFINITION.

We assume that we have two measurement vectors:  $\vec{\eta}$ ,  $\vec{\xi}$ , each with  $n$  components, measured independently, where

$$\vec{\eta} = \vec{y} + \vec{\epsilon}$$

$$\vec{\xi} = \vec{x} + \vec{\delta}$$



$$E\{\vec{\epsilon}\} = E\{\vec{\delta}\} = \vec{\phi}$$

$$\text{Cov}\{\epsilon > \epsilon\} = E\{\epsilon > \epsilon\} = Q_y$$

$$\text{Cov}\{\delta > \delta\} = E\{\delta > \delta\} = Q_x$$

and both  $\vec{\eta}$  and  $\vec{\xi}$  have a Normal distribution. Further:

$$y_i = p_0 + p_1 x_i + p_2 x_i^2 + \dots + p_m x_i^m .$$

Thus we can write:

$$\vec{y} = D_0(\vec{x}) \vec{p}$$

where

$$\vec{p} = \begin{bmatrix} p_0 \\ p_1 \\ \cdot \\ \cdot \\ p_n \end{bmatrix}$$

We also assume that we have a prior distribution which describes our faith in the initial estimates of the parameters in  $\vec{p}$ , also normally distributed. This ad hoc "Bayesian" adjunct is used to control the excursions on the adjustment of the parameters. The danger in its use lies in the fact that for any "small" variance on a parameters, we must be sure that particular parameter is well-known. On the other hand [7], this "control function" can force convergence in an, otherwise, divergent problem.

We can then write the likelihood function as:

$$L = K \exp\left\{-\frac{1}{2} \langle \epsilon Q_y^{-1} \epsilon \rangle - \frac{1}{2} \langle \delta Q_x^{-1} \delta \rangle - \frac{1}{2} \langle \Delta p_c Q_p^{-1} \Delta p_c \rangle \right\}$$

where

$$K = (2\pi)^{-(n+[m+1]/2)} |Q_y^{-1}| |Q_x^{-1}| |Q_p^{-1}|$$

$$\Delta \vec{p}_o = \vec{p} + \vec{p}'_o,$$

where  $p'_o$  will represent the initial estimates of the parameters, and  $Q_p$  will be chosen as a diagonal matrix whose diagonal components are the variances assumed for the parameters in  $\vec{p}$ . It has been found that one parameter is more likely to be known than any of the others. In this problem the bias (i.e.:  $p_o$ ) is likely to be best known, so  $\text{Var}(p_o)$  will be small. The variances of the other terms in  $\vec{p}$  will be set to  $10^{12}$ . The effect of this procedure (through not on a polynomial) was documented in [7].

Thus, our minimization function, I, can be written [8] as:

$$I = \langle \epsilon Q_y^{-1} \epsilon \rangle + \langle \delta Q_x^{-1} \delta \rangle + \langle \Delta p_o Q_p^{-1} \Delta p_o \rangle .$$

#### IV. DERIVATION OF THE MINIMIZATION FUNCTIONS.

The approach toward minimization will be by the method of steepest descent using an iterative procedure. That is, we will add adjustments to the variables until the magnitude of the adjustments approaches zero. A moment's reflection [9] indicates that we will adjust the independent variable,  $\vec{x}$ , and the parameter vector,  $\vec{p}$ , until the residuals  $\vec{\epsilon}$  and  $\vec{\delta}$  minimize I. Since we are assuming analyticity in a neighborhood of  $\vec{\eta}$ ,  $\vec{\epsilon}$  and  $\vec{p}'_o$ , we can expand  $\vec{x}$  and  $\vec{p}$  in a Taylor's expansion, and since the method of steepest descent is a first-order process we will write:

$$\vec{x} = \vec{x}_o + \Delta \vec{x}$$

$$\vec{y} = \vec{y}_o + \Delta \vec{y}$$

and since

$$\Delta \vec{p}_p = \vec{p} - \vec{p}'_o \rightarrow \Delta \vec{p}_o = \vec{p}_1 + \Delta \vec{p} ,$$

$$\vec{p}_1 \triangleq \vec{p}_o - \vec{p}'_o$$

where it is understood that the "o" subscript (except on  $\vec{p}'_0$ ) refers to the value of the variable during any iteration.

For the remainder of this section we will assume that n measurements have been made of the variables  $\eta_i$  and  $\xi_i$  so that  $\vec{\eta}, \vec{\xi}, \vec{y}, \vec{x}$  and  $\Delta\vec{x}$  are n-components vectors. The definition of the order of the polynomial will be changed to m-1 so that  $\vec{p}, \vec{p}_0, \vec{p}_1, \vec{p}'_0$  and  $\Delta\vec{p}$  are m-component vectors.

#### A. Characterization of $\vec{\epsilon}$

We expand  $\vec{\epsilon}$  in a Taylor's series retaining the first two terms. Thus:

$$\epsilon > = \epsilon_0 > + \left( \frac{\partial}{\partial \vec{x}} > \langle \epsilon \rangle_0^T \Delta \vec{x} > + \left( \frac{\partial}{\partial \vec{p}} > \langle \epsilon \rangle_0^T \Delta \vec{p} > .$$

##### 1. Derivation of $\left( \frac{\partial}{\partial \vec{x}} > \langle \epsilon \rangle \right)$

Let  $J_y \stackrel{\Delta}{=} D_0(\vec{x})$ . Then

$$\epsilon > = \eta > - J_y p >$$

from which, using the method developed by Dalton in [8, Appendix C] for forming the partial derivative of arrays with respect to arrays we can write:

$$\begin{aligned} \left( \frac{\partial}{\partial \vec{x}} > \langle \epsilon \rangle \right) &= \frac{\partial}{\partial \vec{x}} > \{ \langle \eta \rangle - \langle p J_y^T \rangle \} = - \left( \frac{\partial}{\partial \vec{x}} > \langle p J_y^T \rangle \right) \\ &= -\zeta_1 \left\{ \frac{\partial}{\partial \vec{x}} > J_y \right\} \zeta_2 \{ p > \} \end{aligned}$$

$$\left( \frac{\partial}{\partial x} \gg \epsilon \right) = - \left[ \begin{array}{cccc} I_n & I_n & \dots & I_n \end{array} \right]_{1 \times n} \cdot \left[ \begin{array}{ccc} \frac{\partial}{\partial x} \gg J_{y1} & \phi & \\ \frac{\partial}{\partial x} \gg J_{y2} & \cdot & \\ \cdot & \cdot & \\ \phi & \frac{\partial}{\partial x} \gg J_{yn} & \end{array} \right]_{n \times n}$$

$$x \left[ \begin{array}{ccc} p > & & \phi \\ & p > & \\ & & \cdot \\ \phi & & p > \end{array} \right]_{n \times n}$$

where

$$J_y = \left[ \begin{array}{c} \langle J_{y1} \\ \langle J_{y2} \\ \vdots \\ \langle J_{yn} \end{array} \right]$$

Now, since

$$\langle J_{yi} = [ 1 \quad x_i \quad x_i^2 \quad \dots \quad x_i^{m-1} ]$$

we have that

$$\left( \frac{\partial}{\partial x} \gg J_{yi} \right) = \left[ \begin{array}{c} \phi \\ \langle D_{1_i}(x_i) \rangle \leftarrow i^{\text{th}} \text{ row} \\ \phi \end{array} \right]$$

Thus, this derivative is :

$$\begin{aligned}
 -\zeta_1 \left\{ \frac{\partial}{\partial x} \right\} \zeta_2 \{p\} &= \left[ \frac{\partial}{\partial x} \langle J_{y1} \rangle \frac{\partial}{\partial x} \langle J_{y2} \rangle \cdots \frac{\partial}{\partial x} \langle J_{yn} \rangle \right] \\
 &= - \begin{bmatrix} \langle D_1(x_1) \rangle & \phi & & \\ & \langle D_1(x_2) \rangle & & \\ & \phi & \dots & \\ & & & \langle D_1(x_n) \rangle \end{bmatrix} \\
 &= - \Gamma[D_1(\vec{x})] .
 \end{aligned}$$

Now, the  $i^{\text{th}}$  term in  $\Gamma[D_1(\vec{x})]$  is

$$\langle D_1(x_i) \rangle$$

and since  $p = p_0 + \Delta p$  we have:

$$\langle D_1(x_i) \rangle = \langle D_1(x_i) \rangle_{p_0} + \langle D_1(x_i) \rangle_{\Delta p} .$$

The term  $\langle D_1(x_i) \rangle$  can be written as:

$$\begin{aligned}
 &= [ 0 \quad 1 \quad 2x_i \quad 3x_i^2 \quad \cdots \quad (m-1)x_i^{m-2} ] \\
 &\approx [ 0 \quad 1 \quad 2(x_{i_0} + \Delta x_i) \quad 3(x_{i_0} + \Delta x_i)^2 \quad \cdots \quad (m-1)(x_{i_0} + \Delta x_i)^{m-2} ] \\
 &\approx [ 0 \quad 1 \quad 2x_{i_0} + 2\Delta x_i \quad 3x_{i_0}^2 + 3 \cdot 2x_{i_0} \Delta x_i \quad \cdots \\
 &\qquad\qquad\qquad (m-1)x_{i_0}^{m-2} + (m-1)(m-2)x_{i_0}^{m-3} \Delta x_x ] \\
 &= \langle D_1(x_{i_0}) \rangle + \Delta x_i \langle D_2(x_{i_0}) \rangle
 \end{aligned}$$

From which

$$\begin{aligned}
 \langle D_1(x_i) \rangle p &\approx \langle D_1(x_{i_0}) \rangle p_0 + \langle D_2(x_{i_0}) \rangle p_0 \Delta x_i \\
 &\quad + \langle D_1(x_{i_0}) \rangle \Delta p + \langle D_2(x_{i_0}) \rangle \Delta p \Delta x_i
 \end{aligned}$$

If we define

$$\Delta x > \Delta = \begin{bmatrix} \Delta x_1 \\ \Delta x_2 \\ \vdots \\ \Delta x_n \end{bmatrix}$$

then under the aegis of the assumption of analyticity in the neighborhood of  $\vec{x}_0$

we can drop second-order terms and write:

$$\Gamma[D_1(\vec{x})p\rangle] \approx \Gamma[D_1(\vec{x}_0)p_0\rangle] + \Gamma[D_1(\vec{x}_0)\Delta p\rangle] \\ + \Gamma[D_2(\vec{x}_0)p_0\rangle]\Gamma[\Delta\vec{x}]$$

$$\stackrel{\Delta}{=} J_{xp} \quad \stackrel{\Delta}{=} J_{xpo} + J_{xpl} + J_{xp2}$$

respectively. Thus:

$$\left(\frac{\partial}{\partial x} \gg \epsilon\right) \approx - J_{xp} \stackrel{\Delta}{=} -J_{xpo} - J_{xpl} - J_{xp2}$$

## 2. Derivation of $\left(\frac{\partial}{\partial p} \gg \epsilon\right)$

$$\left(\frac{\partial}{\partial p} \gg \epsilon\right) = \frac{\partial}{\partial p} \langle \langle \eta - \langle p J_y^T \rangle \rangle \rangle \\ = - J_y^T$$

## B. Characterization of $\vec{\delta}$

In a manner similar to that above, we have the following:

$$\delta\rangle = \delta_0\rangle + \left(\frac{\partial}{\partial x} \gg \delta\right)_0^T \Delta x\rangle + \left(\frac{\partial}{\partial p} \gg \delta\right)_0^T \Delta p\rangle$$



$$\left(\frac{\partial}{\partial x} \gg \delta\right) = \frac{\partial}{\partial x} \langle \xi - \langle x \rangle \rangle = -I_n$$

$$\left(\frac{\partial}{\partial p} \gg \delta\right) = \phi .$$

C. Characterization of  $J_y$

Since  $J_y = D_o(\vec{x})$ , expanding this similarly to the one done above for  $\left(\frac{\partial}{\partial x} \gg J_y\right)$  we have that

$$\begin{aligned} J_y &= D_o(\vec{x}) \approx D_o(\vec{x}_o) + \Gamma[\Delta\vec{x}]D_1(\vec{x}_o) \\ &\stackrel{\Delta}{=} J_{y_o} + \Delta J_y, \text{ resp.} \end{aligned}$$

D. Reformulation of the Minimization Functional, I

We can write  $\vec{\epsilon}$  and  $\vec{\delta}$  as:

$$\begin{aligned} \epsilon \rangle &= \epsilon_o \rangle - \Gamma[D_1(\vec{x})p \rangle] \Delta x \rangle - J_y \Delta p \rangle \\ &= \epsilon_o \rangle - J_{xp} \Delta x \rangle - J_y \Delta p \rangle \end{aligned}$$

$$\delta \rangle = \delta_o \rangle - \Delta x \rangle .$$

Thus;

$$\begin{aligned} I &= \langle \epsilon Q_y^{-1} \epsilon \rangle + \langle \delta Q_x^{-1} \delta \rangle + \langle \Delta p_o Q_p^{-1} \Delta p_o \rangle \\ &= (\langle \epsilon_o - \langle \Delta x J_{xp} - \langle \Delta p J_y^T \rangle Q_y^{-1} \epsilon \rangle + (\langle \delta_o - \langle \Delta x \rangle Q_x^{-1} \delta \rangle \\ &\quad + (\langle p_1 + \langle \Delta p \rangle Q_p^{-1} \Delta p_o \rangle \end{aligned}$$

$$\begin{aligned}
I &= \langle \varepsilon_o Q_y^{-1} \varepsilon_o \rangle - 2 \langle \varepsilon_o Q_y^{-1} J_{xp} \Delta x \rangle - 2 \langle \varepsilon_o Q_y^{-1} J_y \Delta p \rangle \\
&+ \langle \Delta x J_{xp} Q_y^{-1} J_{xp} \Delta x \rangle + 2 \langle \Delta x J_{xp} W_y^{-1} J_y \Delta p \rangle \\
&+ \langle \Delta p J_y^T Q_y^{-1} J_y \Delta p \rangle + \langle \delta_o Q_x^{-1} \delta_o \rangle \\
&= 2 \langle \delta_o Q_x^{-1} \Delta x \rangle + \langle \Delta x Q_x^{-1} \Delta x \rangle \\
&+ \langle p_1 Q_p^{-1} p_1 \rangle + 2 \langle p_1 Q_p^{-1} \Delta p \rangle + \langle \Delta p Q_p^{-1} \Delta p \rangle
\end{aligned}$$

Since we wish to keep terms of no higher than second-order we have:

1.  $\langle \varepsilon_o Q_y^{-1} J_{xp} \Delta x \rangle \approx \langle \varepsilon_o Q_y^{-1} J_{xpo} \Delta x \rangle + \langle \varepsilon_o Q_y^{-1} J_{xpl} \Delta x \rangle$   
 $+ \langle \varepsilon_o Q_y^{-1} J_{xp2} \Delta x \rangle$
2.  $\langle \varepsilon_o Q_y^{-1} J_y \Delta p \rangle \approx \langle \varepsilon_o Q_y^{-1} J_{yo} \Delta p \rangle + \langle \varepsilon_o Q_y^{-1} \Delta J_{y1} \Delta p \rangle$
3.  $\langle \Delta x J_{xp} Q_y^{-1} J_{xp} \Delta x \rangle \approx \langle \Delta x J_{xpo} Q_y^{-1} J_{xpo} \Delta x \rangle$
4.  $\langle \Delta x J_{xp} Q_y^{-1} J_y \Delta p \rangle \approx \langle \Delta x J_{xpo} Q_y^{-1} J_{yo} \Delta p \rangle$
5.  $\langle \Delta p J_y^T Q_y^{-1} J_y \Delta p \rangle \approx \langle \Delta p J_{yo}^T Q_y^{-1} J_{yo} \Delta p \rangle$  .

Make the following definitions:

$$K_o \triangleq \langle \epsilon_o Q_y^{-1} \epsilon_o \rangle + \langle \delta_o Q_x^{-1} \delta_o \rangle + \langle p_1 Q_p^{-1} p_1 \rangle$$

$$\epsilon_A \rangle \triangleq Q_y^{-1} \epsilon_o \rangle$$

$$\delta_A \rangle \triangleq Q_x^{-1} \delta_o \rangle .$$

Then:

$$\begin{aligned} I \approx & K_o - 2\langle \epsilon_A^J J_{xpo} \Delta x \rangle - 2\langle \epsilon_A^J J_{xpl} \Delta x \rangle - 2\langle \epsilon_A^J J_{xpo} \Delta x \rangle \\ & - 2\langle \epsilon_A^J J_{yo} \Delta p \rangle - 2\langle \epsilon_A^J J_y \Delta p \rangle + \langle \Delta x J_{xpo} Q_y^{-1} J_{xpo} \Delta x \rangle \\ & + 2\langle \Delta x J_{xpo} Q_y^{-1} J_{yo} \Delta p \rangle + \langle \Delta p J_{yo}^T Q_y^{-1} J_{yo} \Delta p \rangle - 2\langle \delta_A \Delta x \rangle \\ & + \langle \Delta x Q_x^{-1} \Delta x \rangle + 2\langle p_1 Q_p^{-1} \Delta p \rangle + \langle \Delta p Q_p^{-1} \Delta p \rangle . \end{aligned}$$

#### E. Minimization of I

I will be a minimum when

$$\frac{\partial I}{\partial \Delta x} \rangle = \phi \rangle \quad \text{and} \quad \frac{\partial I}{\partial \Delta p} \rangle = \phi \rangle$$

1. Derivation of  $\frac{\partial I}{\partial \Delta x} \rangle = \phi \rangle$

$$\begin{aligned} \frac{\partial I}{\partial \Delta x} \rangle &= \phi = -J_{xpo} \epsilon_A \rangle - J_{xp2} \epsilon_A \rangle \\ &- \zeta_1 \left\{ \frac{\partial}{\partial \Delta x} \rangle J_{xp2} \right\} \zeta_2 \{ \Delta \vec{x} \} \epsilon_A \rangle - \zeta_1 \left\{ \frac{\partial}{\partial \Delta x} \rangle \Delta J_y \right\} \zeta_2 \{ \Delta \vec{p} \} \epsilon_A \rangle \\ &+ J_{xpo} Q_y^{-1} J_{xpo} \Delta x \rangle + J_{xpo} Q_y^{-1} J_{yo} \Delta p \rangle - 2\delta_A \rangle + Q_x^{-1} \Delta x \rangle. \end{aligned}$$

We note that the diagonalizing function  $\Gamma[\cdot]$  has the following characteristic:

$$\Gamma[\vec{v}]w \rangle = \Gamma[\vec{w}]v \rangle, \quad \forall \vec{v}, \vec{w}.$$

Thus we can write:

$$\begin{aligned} \text{a. } J_{xpo} \epsilon_p \rangle &= \Gamma[D_1(\vec{x}_o) p_o \rangle] \epsilon_A \rangle \\ &= \Gamma[\vec{\epsilon}_A] A_1(\vec{x}_o) p_o \rangle \\ \text{b. } J_{xpl} \epsilon_A \rangle &= \Gamma[D_1(\vec{x}_o) \Delta p \rangle] \epsilon_A \rangle = \Gamma[\vec{\epsilon}_A] D_1(\vec{x}_o) p_o \rangle \\ \text{c. } J_{xp2} \epsilon_A \rangle &= \Gamma[D_2(\vec{x}_o) p_o \rangle] \Gamma[\Delta \vec{x}] \epsilon_A \rangle \\ &= \Gamma[D_2(\vec{x}_o) p_o \rangle] \Gamma[\vec{\epsilon}_A] \Delta x \rangle \end{aligned}$$

$$\begin{aligned}
 \text{d. } \zeta_1 \left\{ \frac{\partial}{\partial \Delta x} \right\}_{xp2} \zeta_2 \{ \Delta \vec{x} \} \epsilon_A > \\
 = \zeta_1 \left\{ \frac{\partial}{\partial \Delta x} \right\}_{\Gamma[\Delta \vec{x}]} \zeta_2 \{ \Gamma[D_2(\vec{x}_0) p_0] \Delta x \} \epsilon_A >
 \end{aligned}$$

Define  $e_i >$  as the  $i^{\text{th}}$  orthonormal vector. That is, a vector with all zeros except the  $i^{\text{th}}$  component which is a one. Then if:

$$E_i \stackrel{\Delta}{=} e_i > \langle e_i$$

$$\begin{aligned}
 \text{a. } \zeta_1 \left\{ \frac{\partial}{\partial \Delta x} \right\}_{xp2} \zeta_2 \{ \Delta \vec{x} \} \epsilon_A > \\
 = [E_1 \Gamma[D_2(\vec{x}_0) p_0] \Delta x > \cdot \cdot \cdot E_n \Gamma[D_2(\vec{x}_0) p_0] \Delta x >] \epsilon_A >
 \end{aligned}$$

$$E_i \Gamma[D_2(\vec{x}_0) p_0] \Delta x > = \begin{bmatrix} \phi > \\ \Delta x_i \langle D_2(x_{i0}) p_0 > \\ \phi > \end{bmatrix} \leftarrow i^{\text{th}} \text{ row}$$

$$\zeta_1 \left\{ \frac{\partial}{\partial \Delta x} \right\}_{xp2} \zeta_2 \{ \Delta \vec{x} \} \epsilon_A >$$

$$= \begin{bmatrix} \langle D_2(x_{10}) p_0 > \Delta x_1 & & & & \\ & \langle D_2(x_{20}) p_0 > \Delta x_2 & & & \phi \\ & & \cdot & & \\ \phi & & & \cdot & \\ & & & & \cdot \\ & & & & \langle D_2(x_{n0}) p_0 > \Delta x_n \end{bmatrix}$$

$$= \Gamma[D_2(\vec{x}_0)] \Gamma[\Delta \vec{x}] \epsilon_A >$$

$$= \Gamma[\vec{\epsilon}_A] \Gamma[D_2(\vec{x}_0) p_0] \Delta x >$$

$$\begin{aligned}
\text{b. } \zeta_1 \left\{ \frac{\partial}{\partial \Delta x} \right\} \Delta J_y \zeta_2 \{ \Delta p \} \epsilon_A > \\
= \zeta_1 \left\{ \frac{\partial}{\partial \Delta x} \right\} \langle \Gamma[\Delta \vec{x}] D_1(\vec{x}_0) \rangle \zeta_2 \{ \Delta \vec{p} \} \epsilon_A > \\
= [E_1 D_1(\vec{x}_0) \Delta p > \cdots E_n D_1(\vec{x}_0) \Delta p >] \epsilon_A >
\end{aligned}$$

$$E_1 D_1(\vec{x}_0) \Delta p > = \begin{bmatrix} \phi > \\ \langle D_1(x_{10}) \Delta p > \\ \phi > \end{bmatrix}$$

$$\zeta_1 \left\{ \frac{\partial}{\partial \Delta x} \right\} \Delta J_y \zeta_2 \{ \Delta \vec{p} \} \epsilon_A > = \begin{bmatrix} \langle D_1(x_{10}) \Delta p > & & & & & & \\ & \langle D_1(x_{20}) \Delta p > & & & & \phi & \\ & & \cdot & & & & \\ & & & \cdot & & & \\ & \phi & & & & & \\ & & & & & & \\ & & & & & & \langle D_1(x_{no}) \Delta p > \end{bmatrix}$$

$$\begin{aligned}
&= \Gamma[D_1(\vec{x}_0) \Delta p >] \epsilon_A > \\
&= \Gamma[\vec{\epsilon}_A] D_1(\vec{x}_0) \Delta p > .
\end{aligned}$$

If we make the following definitions

$$\begin{aligned}
R_1 > \triangleq \Gamma[\vec{\epsilon}_A] D_1(\vec{x}_0) p_0 > + \delta_A > \\
&= \Gamma[D_1(\vec{x}_0) p_0 >] \epsilon_A > + \delta_A >
\end{aligned}$$

$$S_1 \triangleq -2\Gamma[\vec{\epsilon}_A] + \Gamma[D_1(\vec{x}_0) p_0 >] Q_y^{-1} D_0 x_0 >$$

$$\begin{aligned}
S_2 \triangleq -2\Gamma[\vec{\epsilon}_A] \Gamma[D_2(\vec{x}_0) p_0 >] + Q_x^{-1} \\
+ \Gamma[D_1(\vec{x}_0) p_0 >] Q_y^{-1} \Gamma[D_1(\vec{x}_0) p_0 >]
\end{aligned}$$

Then

$$\begin{aligned}
\frac{\partial I}{\partial \Delta x} > &= \phi \Rightarrow S_1 \Delta p > + S_2 \Delta x > - R_1 > \\
&= \phi > .
\end{aligned}$$

2. Derivation of  $\frac{\partial I}{\partial \Delta p} > = \Phi >$ .

$$\begin{aligned} \frac{\partial I}{\partial \Delta p} > = \Phi &= - \frac{\partial}{\partial \Delta p} > (\langle \epsilon_A^J J_{xpl} \Delta x \rangle) - J_{y_0}^T \epsilon_A > \\ &\quad - 2 \Delta J_y^T \epsilon_A > + J_{y_0}^T Q_y^{-1} J_{xpo} \Delta x > \\ &\quad + J_{y_0}^T Q_y^{-1} J_{y_0} \Delta p > + Q_p^{-1} p_1 > + Q_p^{-1} \Delta p > . \end{aligned}$$

Observe the following terms:

$$\begin{aligned} \text{a. } \frac{\partial}{\partial \Delta p} > (\langle \epsilon_A^J J_{xpl} \Delta x \rangle) &= \frac{\partial}{\partial \Delta p} > (\langle \epsilon_A \Gamma [D_1(\vec{x}_0) \Delta p] \Delta x \rangle) \\ &= \frac{\partial}{\partial \Delta p} > (\langle \epsilon_A \Gamma [\Delta \vec{x}] D_1(\vec{x}_0) \Delta p \rangle) \\ &= D_1^T(\vec{x}_0) \Gamma [\Delta \vec{x}] \epsilon_A > = D_1^T(\vec{x}_0) \Gamma [\vec{\epsilon}_A] \Delta x > \end{aligned}$$

$$\begin{aligned} \text{b. } \Delta J_y^T \epsilon_A > &= D_1^T(\vec{x}_0) \Gamma [\Delta \vec{x}] \epsilon_A > \\ &= D_1^T(\vec{x}_0) \Gamma [\vec{\epsilon}_A] \Delta x > \end{aligned}$$

Making the following definitions:

$$R_2 > \triangleq D_0^T(\vec{x}_0) \epsilon_A > + Q_p^{-1} p_1 >$$

$$S_3 \triangleq D_0^T(\vec{x}_0) Q_y^{-1} D_0(\vec{x}_0) + Q_p^{-1}$$

Then

$$\frac{\partial I}{\partial \Delta p} > = \Phi > \Rightarrow S_3 \Delta p > + S_1^T \Delta x > - R_2 > = \Phi > .$$

3. Solving for  $\Delta p >$  and  $\Delta x >$ .

We have two equations in two unknowns, vis.:

$$S_1 \Delta p > + S_2 \Delta x > = R_1 >$$

$$S_3 \Delta p > + S_1^T \Delta x > = R_2 >$$

in which  $S_2$  and  $S_3$  have inverses. Make the following definitions:

$$S_A \triangleq S_2^{-1} S_1$$

$$R_A > \triangleq S_2^{-1} R_1 >$$

$$Q_A \triangleq S_1^T S_A - S_3$$

$$V_A > \triangleq S_1^T R_A > - R_2 >$$

then:

$$\Delta p > = Q_A^{-1} V_A >$$

$$\Delta x > = R_A > - S_A \Delta p > .$$

#### V. INITIALIZATION.

The "best" initial estimate for  $\vec{p}$  is obtained (unless additional information is available) from the normal equations. Thus



$$I_1 = \langle \epsilon Q_y^{-1} \epsilon \rangle + \langle \delta Q_x^{-1} \delta \rangle$$

$$\begin{aligned} \frac{\partial I_1}{\partial p} > = \frac{\partial}{\partial p} > [(\langle \eta - \langle p J_y^T \rangle Q_y^{-1} \epsilon \rangle \\ + (\langle \xi - \langle x \rangle Q_x^{-1} \delta \rangle)] \end{aligned}$$

$$= -2 J_y^T Q_y^{-1} (\eta > - J_y >)$$

$$\frac{\partial I_1}{\partial p} > = \phi \Rightarrow$$

$$p_o' > = (J_y^T Q_y^{-1} J_y)^{-1} J_y^T Q_y^{-1} \eta >$$

$$x_o > = \xi > .$$

VI. AN ADDITIONAL METHOD FOR CONTROLLING DIVERGENCE FOR THE CASE:  $Q_x = Q_y = I$

The algorithm derived in the previous pages was based on a linear approximation for the error in an assumed analytic neighborhood of the true solution. Inasmuch as both the dependent and independent variables are adjusted to achieve a minimum, the algorithm is usually sensitive to noise and the large excursions of the dependent variable. Indeed, in the form shown there is definitely a tendency for the algorithm to be unstable and to diverge with unbecoming frequency.

A large number of empirical studies were made for various kinds of polynomials under various conditions of noise content (in which the basic premise for which the study was intended, namely:  $Q_x = Q_y = I$ , was assumed) and comparisons were made among those which diverged and those which converged. The criteria which distinguished the convergent polynomials from the divergent ones surprised this author. At this writing, the author has not studied the theoretical aspects and cannot supply the reasons. (One might suspect that an investigation similar to that employed which demonstrates the reasons for the instabilities of Milne's integration method, might help toward an understanding of this problem.)

Early, it was found that if the input were randomized, formerly divergent problems would converge, though not always.<sup>1</sup> Figures 1 to 4 show a study in which the algorithm diverged after randomization. (It diverged before randomization, but this result is not shown.)

---

1. All work was computed in double precision.

$$I_1 = \langle \epsilon Q_y^{-1} \epsilon \rangle + \langle \delta Q_x^{-1} \delta \rangle$$

$$\begin{aligned} \frac{\partial I_1}{\partial p} > &= \frac{\partial}{\partial p} > [(\langle \eta - \langle p J_y^T \rangle Q_y^{-1} \epsilon \rangle \\ &+ (\langle \xi - \langle x \rangle Q_x^{-1} \delta \rangle)] \end{aligned}$$

$$= -2 J_y^T Q_y^{-1} (\eta > - J_y >)$$

$$\frac{\partial I_1}{\partial p} > = \phi \Rightarrow$$

$$p_o' > = (J_y^T Q_y^{-1} J_y)^{-1} J_y^T Q_y^{-1} \eta >$$

$$x_o > = \xi > .$$

VI, AN ADDITIONAL METHOD FOR CONTROLLING DIVERGENCE FOR THE CASE:  $Q_x = Q_y = I$

The algorithm derived in the previous pages was based on a linear approximation for the error in an assumed analytic neighborhood of the true solution. Inasmuch as both the dependent and independent variables are adjusted to achieve a minimum, the algorithm is usually sensitive to noise and the large excursions of the dependent variable. Indeed, in the form shown there is definitely a tendency for the algorithm to be unstable and to diverge with unbecoming frequency.

A large number of empirical studies were made for various kinds of polynomials under various conditions of noise content (in which the basic premise for which the study was intended, namely:  $Q_x = Q_y = I$ , was assumed) and comparisons were made among those which diverged and those which converged. The criteria which distinguished the convergent polynomials from the divergent ones surprised this author. At this writing, the author has not studied the theoretical aspects and cannot supply the reasons. (One might suspect that an investigation similar to that employed which demonstrates the reasons for the instabilities of Milne's integration method, might help toward an understanding of this problem.)

Early, it was found that if the input were randomized, formerly divergent problems would converge, though not always.<sup>1</sup> Figures 1 to 4 show a study in which the algorithm diverged after randomization. (It diverged before randomization, but this result is not shown.)

---

1. All work was computed in double precision.

A number of additional studies involving polynomials of various shapes disclosed the rather surprising fact that, apparently, the only criterion needed to insure convergence was that the (scaled) slope of a line based on the total height of the first and last points of the variables must be less than  $45^\circ$ ,<sup>1</sup> if the terms in the independent variable were monotonically nondecreasing.

A scaling criterion was introduced which compared  $|\xi_n + \xi_1| = \xi_s$  with  $|\eta_n + \eta_1| = \eta_s$ . If  $\xi_s < \eta_s$ , the data in  $\vec{\eta}$  was replaced by  $s \cdot \vec{\eta}$  where  $s = 0.9 \xi_s / \eta_s$ . Figures 5 to 10 demonstrate the effect on identical data of the divergent problem (figures 1 to 4) subject to this scaling criterion. In this case, the algorithm converged.

The data for the above studies were generated from the polynomial:

$$y = 22.5 + 2.125 x - 0.5 x^2 + 0.03125 x^3$$

to which zero-mean Gaussian noise with a variance of 0.02 had been added to each of the 2n observations in  $\vec{\xi}$  and  $\vec{\eta}$  resp. Further studies were done in which the variance of the noise was increased to 4.0, which is the same size as the first point of the independent variable, and the domain of the independent variable was decreased so that it ranged through the values: 4.0, 4.2, ..., 13.8. The algorithm still converged when the independent variable was rescaled, but not surprisingly, the number of iterations increased substantially. These results are not shown.

- 
1. It might be of interest that the first attempt at rescaling was to make  $\vec{\xi}$  and  $\vec{\eta}$  each a unit vector. This didn't affect the divergence or convergence tendency at all.

Figures 11 to 15 show the convergence of the algorithm based on the polynomial:

$$y = 12.0 + 7.0 x - 0.2 x^2 - 0.1 x^3$$

in which the variance was again 0.02. This curve is dome-shaped and so constructed that  $y_1$  and  $y_n$  are sufficiently close together that the data was barely rescaled. This demonstrates the, apparently, sufficient criterion that the slope based on the first and last point determine whether the algorithm will converge or not.

Finally, Figures 16 to 18 show the convergence of the algorithm from data obtained manually using a ruler and a strip chart. Furthermore, the curve from which the measurements were obtained jittered over a width of about 3/8 of an inch. Such data is crude by any standards for computer work, but, hearteningly, the algorithm converged nicely. Several other studies using data obtained in a similar manner from similar sources always had a convergent algorithm when the rescaling criterion was employed.

## VII. RESULTS AND CONCLUSIONS.

This paper has discussed the problems of a minimum variance iterative first-order solution for two noisy vector variables, a dependent and an independent one, in which the dependent variable is related to the independent variable by a polynomial. A number of studies were made using a variety of polynomial shapes, of degree three. It was assumed that the noise on each independent observation was Gaussian with a zero mean. The variance of the noise was varied from 0.02 to 4.0, the latter of the same order of magnitude as the independent variable.

Two criteria for assisting algorithm convergence have been introduced:

(i) An ad hoc Bayesian distribution which controlled the excursions of the polynomial coefficients,

(ii) Rescaling the dependent variable so that the slope based on the first and last data point was less than  $45^\circ$ .

Of the three criteria no studies have been presented using criterion (i), but the effectiveness of this method has been discussed in [7].

Rather complete studies based on criterion (ii) were made using a 3<sup>rd</sup> order polynomial in which  $Q_x = Q_y = I$ . That is, a least squares solution. For all cases tried, the algorithm converged everytime. At present, because of the original goals of the problem, the use of (ii) as a convergence criteria is deemed adequate for the requirements of the project.

REFERENCES.

1. Kendall, M.G. and Stuart, A., The Advanced Theory of Statistics, Chas Griffin and Co., Ltd, London, Vol 2, 1961.
2. Morrison, D.F., Multivariate Statistical Methods, McGraw - Hill Book Co., NY, NY 1967.
3. Worthing, A.G. and Geffner, J., Treatment of Experimental Data, John Wiley and Sons, Inc., NY, NY 1950.
4. Geary, R.C. Non-linear Functional Relationship Between Two Variables When One Variable is Controlled, J. Amer. Statist Ass., 48, 94, 1953.
5. Dalton, O.N., Transformations Through a Non-Euclidean Space in a Linear Transformation Context, Application of First-degree-affine Transformation to Probability Density Functions in the  $\alpha$ -Log Space, Paper presented at the 19<sup>th</sup> conference on the Design of Exp in Army Res., Dev. and Testing, Rock Island, Ill, Oct 1973, to be published.
6. Anderson, T.W., An Introduction to Multivariate Statistical Analysis, John Wiley and Sons, NY 1958.
7. Dalton, O.N., Minimization Procedure for Assessing Instrumentation and Geographical Location Bias Errors, Report No 98 92.40-502, TRW, Space Technology Lab. Redondo Beach CA, July 1963.
8. Brown, D.C. A Treatment of Analytical Photogrammetry, RCA Data Red. Tech. Report No. 39, 20 Aug 1957.
9. Dalton, O.N., Introduction to Minimization Problems and Kalman-Bucy Filter Techniques, Technical Report, An and Comp. Div., WSMR, NM, 1 June 1967.
10. Dalton, O.N., Omphalaskopsis, NR-AM-I, USAWSMR, WSMR, NM 1974.



CONVERGENCE PROGRAM FOR 2-DIMENSIONAL DATA  
 HAVING ERRORS ON BOTH THE DEPENDENT AND THE  
 INDEPENDENT VARIABLES.

THE VARIABLES ARE CONNECTED BY A POLYNOMIAL OF DEGREE 3. USING THE METHOD  
 OF STEEPEST DESCENT, THE CONVERGENCE CRITERIA IS THE MINIMIZATION OF THE  
 CORRECTIONS TO THE INDEPENDENT VARIABLE AND THE COEFFICIENTS OF THE CONNECTING  
 POLYNOMIAL, ASSUMING EQUAL VARIANCES FOR EACH DEPENDENT AND INDEPENDENT  
 VARIABLE, AND MUTUAL INDEPENDENCE AMONG ALL MEASUREMENTS FOR BOTH VARIABLES.

THE PROGRAM WILL STOP AFTER 10 ITERATIONS OR AFTER A CHANGE TO THE  
 POLYNOMIAL COEFFICIENTS IS LESS THAN .00005000

THE PROGRAM IS USING 50 ITEMS OF DATA.

INPUT VALUES FOR THE RESCALED  
 DEPENDENT VARIABLE ARE:

3174.983725  
 56.482853  
 602.498220  
 5680.024781  
 15195.015904  
 7681.009853  
 10104.987180  
 1544.992247  
 114.951233  
 1810.017506  
 20319.992025  
 4061.509561  
 1307.484311  
 14064.987583  
 18945.015154  
 23.511078  
 24485.011876  
 28199.981435  
 376.002510  
 29.982437  
 23266.513906  
 4561.002878  
 25.035980  
 16384.011642  
 25.012002  
 2785.016479  
 6968.982695  
 909.027518  
 2428.491009  
 1096.009304  
 288.985289  
 12992.488852

INPUT VALUES FOR THE  
 DEPENDENT VARIABLE ARE:

3174.983725  
 56.482853  
 602.498220  
 5680.024781  
 15195.015904  
 7681.009853  
 10104.987180  
 1544.992247  
 114.951233  
 1810.017506  
 20319.992025  
 4061.509561  
 1307.484311  
 14064.987583  
 18945.015154  
 23.511078  
 24485.011876  
 28199.981435  
 376.002510  
 29.982437  
 23266.513906  
 4561.002878  
 25.035980  
 16384.011642  
 25.012002  
 2785.016479  
 6968.982695  
 909.027518  
 2428.491009  
 1096.009304  
 288.985289  
 12992.488852  
 9247.487233

INPUT VALUES FOR THE IN-  
 DEPENDENT VARIABLE ARE:

51.999939  
 15.992880  
 31.962431  
 62.024081  
 83.985505  
 67.971547  
 74.009316  
 92.012931  
 20.009021  
 43.981015  
 92.014776  
 55.963291  
 40.011736  
 82.002476  
 90.020059  
 7.996226  
 99.974901  
 101.977198  
 28.026417  
 11.973047  
 96.039764  
 58.006431  
 4.015099  
 86.015006  
 10.007577  
 50.011427  
 65.967355  
 36.003351  
 48.019589  
 37.991414  
 26.004435  
 79.959332  
 72.017050

(FIGURE 1)

75.993703 11014.032263  
 18.007590 81.020061  
 22.044201 159.984201  
 69.981211 8439.953026  
 23.953483 217.541484  
 45.978069 2103.994170  
 53.999206 3599.955579  
 30.033320 479.989731  
 78.014026 11976.011564  
 59.977122 5099.997424  
 14.025598 40.001464  
 87.974629 17633.507326  
 63.996580 6302.511219  
 98.005999 24841.001143  
 33.984627 745.018934  
 94.006388 21760.004519  
 5.982395 23.990270

9247.487253  
 11014.032263  
 81.020061  
 159.984201  
 8439.953026  
 217.541484  
 2103.994170  
 3599.955579  
 479.989731  
 11976.011564  
 5099.997424  
 40.001464  
 17633.507326  
 6302.511219  
 24841.001143  
 745.018934  
 21760.004519  
 23.990270

INITIAL ESTIMATES FOR THE COEFFICIENTS ARE:

20.943388  
 2.257387  
 2.502219  
 .031262

(FIGURE 2)

THE CORRECTIONS TO THE COEFFICIENTS  
AFTER ITERATION 1 ARE:

69.345202  
32.422633  
83.181936  
0045242

THE VALUES OF THE COEFFICIENTS  
AFTER ITERATION 1 ARE:

48.402614  
34.680019  
3.684154  
0076503

THE VALUE OF ONE OF THE COEFFICIENTS HAS EXCEEDED 50  
THE PROCESS IS DIVERGING AND WILL TERMINATE.  
THE ORIGINAL ESTIMATES WILL BE RETAINED.



SCALED ESTIMATES FOR THE COEFFICIENTS ARE:

20.943388  
2.257387  
0.502219  
0.031262

SCALED VALUES FOR THE IN-  
DEPENDENT VARIABLE ARE:

51.999939  
15.992880  
31.962431  
62.024081  
83.985505  
67.971567  
74.009316  
42.012993  
20.009021  
43.981015  
92.014776  
55.963291  
40.011236  
82.002476  
90.020059  
7.996226  
99.974901  
101.977198  
28.026417  
11.973047  
96.039764  
58.006431

INPUT VALUES FOR THE  
DEPENDENT VARIABLE ARE:

3174.983725  
56.482853  
602.498220  
5680.024781  
15195.015904  
7681.009853  
10104.987184  
1544.992247  
114.951234  
1810.017506  
20319.992025  
4061.509561  
1307.484311  
14064.987583  
18945.015154  
23.511078  
26485.011876  
28199.981435  
374.002510  
29.982437  
23266.513906  
450.002878

(FIGURE 3)

4.015099	25.035960
86.015006	16384.011645
10.007577	25.012002
50.011427	2785.016479
65.967355	6968.982695
34.003351	909.027518
48.019589	2428.491009
37.993434	1096.009304
26.004435	288.985289
79.959332	12992.488852
72.017050	9247.487233
75.993703	11014.032263
18.007590	81.020061
22.044201	159.984201
69.981211	8439.953026
23.963483	217.541484
45.978069	2103.994170
53.992204	3599.955579
30.033320	479.989731
78.014026	11976.011564
59.977122	5099.997424
14.025598	40.001464
87.974629	17633.507326
63.996580	6302.511219
98.005999	24841.001143
33.984627	745.018934
94.006388	21760.004519
5.982395	23.990270

THE POLYNOMIAL RELATIONSHIP WHICH RELATES VEL. (FT/SEC) AS A FUNCTION OF TIME (SEC) IS:

$$20.8434 \cdot t^6 - 2.2574 \cdot t^5 + 6.6022 \cdot t^4 - 0.913 \cdot t^3 + \dots$$

(FIGURE 4)

CONVERGENCE PROGRAM FOR 2-DIMENSIONAL DATA  
 HAVING ERRORS ON BOTH THE DEPENDENT AND THE  
 INDEPENDENT VARIABLES.

THE VARIABLES ARE CONNECTED BY A POLYNOMIAL OF DEGREE 3. USING THE METHOD  
 OF STEEPEST DESCENT, THE CONVERGENCE CRITERIA IS THE MINIMIZATION OF THE  
 CORRECTIONS TO THE INDEPENDENT VARIABLE AND THE COEFFICIENTS OF THE CONNECTING  
 POLYNOMIAL, ASSUMING EQUAL VARIANCES FOR EACH DEPENDENT AND INDEPENDENT  
 VARIABLE, AND MUTUAL INDEPENDENCE AMONG ALL MEASUREMENTS FOR BOTH VARIABLES.

THE PROGRAM WILL STOP AFTER 10 ITERATIONS OR AFTER A CHANGE TO THE  
 POLYNOMIAL COEFFICIENTS IS LESS THAN .00000000

THE PROGRAM IS USING 50 ITEMS OF DATA.

INPUT VALUES FOR THE IN-  
 DEPENDENT VARIABLE ARE:

51.999939  
 15.992880  
 31.962431  
 62.024081  
 83.985505  
 67.971567  
 74.009316  
 42.012993  
 20.009021  
 43.981015  
 92.014776  
 55.963291  
 40.011736  
 62.002476  
 90.020059  
 7.996226  
 99.974901  
 101.977198  
 28.026417  
 11.973047  
 96.039764  
 58.006431  
 4.015099  
 86.015006  
 10.007577  
 50.011427  
 65.967355  
 36.003351  
 48.019589  
 37.993434  
 26.004435  
 79.959332  
 72.017050

INPUT VALUES FOR THE  
 DEPENDENT VARIABLE ARE:

3174.983725  
 56.482853  
 602.498220  
 5680.024781  
 15195.015904  
 7681.009853  
 10104.987180  
 1544.992247  
 114.951233  
 1810.017504  
 20319.992025  
 4061.509561  
 1307.484311  
 14064.987583  
 18945.015154  
 23.511078  
 26485.011876  
 28199.981435  
 376.002510  
 29.982437  
 23266.513906  
 4561.002878  
 25.035980  
 16384.011645  
 25.012002  
 2785.016479  
 6968.982695  
 909.027518  
 2428.491009  
 1096.009304  
 288.985289  
 12992.48852  
 9247.487233

INPUT VALUES FOR THE RESCALED  
 DEPENDENT VARIABLE ARE:

51.792753  
 .921391  
 9.828410  
 92.656891  
 242.872673  
 125.298483  
 164.840248  
 25.203090  
 1.875172  
 29.526384  
 331.475187  
 66.254438  
 21.328680  
 229.438791  
 309.045517  
 .383531  
 432.043687  
 460.019577  
 6.133639  
 .489096  
 379.541097  
 74.402553  
 .408906  
 267.268478  
 .408015  
 45.431310  
 113.683354  
 14.828749  
 39.615325  
 17.878939  
 4.714148  
 211.943374

(FIGURE 5)

75.993703	11014.032263	150.852055
18.007590	81.020061	179.669284
22.044201	159.984201	1.321661
69.981211	8439.953026	2.609784
23.953483	217.541484	137.678942
45.878049	2103.994170	3.548202
53.999206	3599.955579	34.321955
30.033320	479.989731	58.725217
78.014024	11976.011564	7.829958
59.977122	5099.997424	195.361823
14.025598	40.001464	83.195043
87.974439	17633.507326	.652534
63.996580	6302.511219	287.651203
98.005999	24841.001143	102.811364
33.984627	745.016934	405.225332
98.006388	21760.004519	12.153316
5.982395	23.990270	354.965768
		.381348

INITIAL ESTIMATES FOR THE COEFFICIENTS ARE:

.341644

.036824

.008193

.000510

(FIGURE 6)

THE CORRECTIONS TO THE COEFFICIENTS  
AFTER ITERATION 1 ARE:

.022806  
 .001800  
 .000020  
 .000000  
 .364350  
 .035024  
 .009172  
 .000510

THE VALUES OF THE COEFFICIENTS  
AFTER ITERATION 1 ARE:

THE CORRECTIONS TO THE INDEPENDENT  
VARIABLES AFTER ITERATION 1 ARE:

THE VALUES OF THE INDEPENDENT  
VARIABLES AFTER ITERATION 1 ARE:

-.000897	51.999041
.000178	15.993058
.020433	31.982864
-.024884	61.999197
.009944	83.995449
.025211	67.996778
-.012403	73.996914
-.010618	42.002375
-.000996	20.008025
.015817	43.994682
-.020090	91.994686
.033354	55.996645
-.009112	40.002625
-.006459	81.995816
-.025027	89.995033
-.000027	7.996198
.018587	99.993488
.016016	101.993213
-.009685	28.016731
.000086	11.973133
-.045344	95.994421
.007544	57.998888
-.000069	4.015030
-.019507	85.995499
-.000005	10.007572
-.010921	50.000505
.029361	65.996716
-.001860	36.001490
-.017880	48.001709
.004932	37.998365
-.001228	26.003208
.036262	79.995594
-.019707	71.997343
.002790	75.996493
-.000279	18.007311
-.006520	22.0037680
.015479	69.996689
.010377	23.9963860
.018577	45.996646
.000517	52.998488
.015105	30.010215

(FIGURE 7)

THE CORRECTIONS TO THE COEFFICIENTS  
AFTER ITERATION 2 ARE:

0.11089  
-0.001739  
-0.00063  
-0.000001

THE VALUES OF THE COEFFICIENTS  
AFTER ITERATION 2 ARE:

0.375339  
0.03285  
-0.008109  
0.000509

THE CORRECTIONS TO THE INDEPENDENT  
VARIABLES AFTER ITERATION 2 ARE:

THE VALUES OF THE INDEPENDENT  
VARIABLES AFTER ITERATION 2 ARE:

-0.003480  
-0.00470  
-0.000798  
-0.002536  
-0.002051  
-0.001561  
-0.000284  
-0.003090  
-0.000862  
-0.003321  
-0.004149  
-0.003331  
-0.002774  
-0.001572  
-0.003603  
-0.000026  
-0.006345  
-0.006925  
-0.000209  
-0.00110  
-0.005179  
-0.003015  
-0.000080  
-0.002566  
-0.000033  
-0.003545  
-0.001943  
-0.001891  
-0.003562  
-0.002356  
-0.000634  
-0.000969  
-0.000720  
-0.000156  
-0.000689  
-0.000907  
-0.001139  
-0.000901  
-0.003483  
-0.003321  
-0.000315

51.995562  
15.993528  
31.9982066  
61.996660  
83.997500  
67.995217  
73.996630  
41.999285  
20.008897  
43.993511  
91.998835  
55.993314  
39.999850  
81.997388  
89.998636  
7.996224  
99.999833  
102.000138  
28.016940  
11.973243  
95.999600  
57.995873  
4.015110  
85.998065  
10.007605  
49.996960  
65.994773  
35.999599  
47.998148  
37.996009  
26.003842  
79.996563  
71.996624  
75.996649  
18.008001  
22.038588  
69.999550  
23.9964761  
45.993163  
51.995318  
30.017900

(FIGURE 8)



THE CORRECTIONS TO THE COEFFICIENTS  
AFTER ITERATION 3 ARE:

000011  
000002  
000000  
000000

THE VALUES OF THE COEFFICIENTS  
AFTER ITERATION 3 ARE:

375329  
033287  
008110  
000509

THE CORRECTIONS TO THE INDEPENDENT  
VARIABLES AFTER ITERATION 3 ARE:

000002  
000001  
000004  
000000  
000006  
000001  
000003  
000003  
000000  
000003  
000008  
000001  
000003  
000005  
000007  
000002  
000009  
000010  
000004  
000000  
000009  
000001  
000009  
000006  
000000  
000002  
000001  
000003  
000000  
000005  
000003  
000004  
000001  
000003  
000002  
000006  
000003  
000002  
000001  
000003  
000002  
000006  
000003  
000002  
000005

THE VALUES OF THE INDEPENDENT  
VARIABLES AFTER ITERATION 3 ARE:

51.995564  
15.993527  
31.982062  
61.996660  
83.997495  
67.995216  
73.996627  
41.999288  
20.008887  
43.993514  
91.998828  
55.993315  
39.999853  
81.997383  
89.998629  
7.996226  
99.999824  
102.000128  
26.016944  
11.973243  
95.999591  
57.995874  
4.015119  
85.998059  
10.007605  
49.996862  
65.999472  
35.999602  
47.998150  
37.996011  
26.003842  
79.996559  
71.996621  
75.996645  
18.008000  
22.038591  
69.995548  
23.964755  
45.993166  
53.995319  
99.997920

(FIGURE 9)

THE ESTIMATED MEAN VALUES OF THE RESIDUALS OF THE SCALED INDEPENDENT AND  
DEPENDENT VARIABLES, RESP., ARE:

0.00000

AND

0.00000

THE ESTIMATED VARIANCES OF THE SCALED INDEPENDENT AND  
DEPENDENT VARIABLES, RESP., ARE:

0.000261

AND

0.150600

(FIGURE 10)

ASSUMING EQUAL VARIANCES AMONG ALL VARIABLES, THE ESTIMATED TOTAL VARIANCE IS:

0.074672

THE POLYNOMIAL RELATIONSHIP WHICH RELATES VEL. (FT/SEC) AS A FUNCTION OF TIME (SEC) IS:

$23.0000 + 2.0405 T - 0.4971 T^2 + 0.0312 T^3$

CONVERGENCE PROGRAM FOR 2-DIMENSIONAL DATA  
 HAVING ERRORS ON BOTH THE DEPENDENT AND THE  
 INDEPENDENT VARIABLES.

THE VARIABLES ARE CONNECTED BY A POLYNOMIAL OF DEGREE 3. USING THE METHOD  
 OF STEEPEST DESCENT, THE CONVERGENCE CRITERIA IS THE MINIMIZATION OF THE  
 CORRECTIONS TO THE INDEPENDENT VARIABLE AND THE COEFFICIENTS OF THE CONNECTING  
 POLYNOMIAL, ASSUMING EQUAL VARIANCES FOR EACH DEPENDENT AND INDEPENDENT  
 VARIABLE, AND MUTUAL INDEPENDENCE AMONG ALL MEASUREMENTS FOR BOTH VARIABLES.

THE PROGRAM WILL STOP AFTER 10 ITERATIONS OR AFTER A CHANGE TO THE  
 POLYNOMIAL COEFFICIENTS IS LESS THAN .00005000

THE PROGRAM IS USING 50 ITEMS OF DATA.

INPUT VALUES FOR THE IN-  
 DEPENDENT VARIABLE ARE:

-2.100159  
 -1.881199  
 -1.713292  
 -1.506355  
 -1.283618  
 -1.106624  
 -.932230  
 -.687602  
 -.505222  
 -.317881  
 -.113687  
 .128944  
 .306280  
 .474279  
 .713586  
 .874532  
 1.102137  
 1.301108  
 1.520840  
 1.700414  
 1.873600  
 2.093855  
 2.299324  
 2.477819  
 2.731918  
 2.923770  
 3.120289  
 3.298056  
 3.508342  
 3.722103  
 3.874984  
 4.092317  
 4.314121

INPUT VALUES FOR THE  
 DEPENDENT VARIABLE ARE:

-2.619920  
 -1.345830  
 .024378  
 1.399502  
 2.764137  
 4.152564  
 5.593753  
 7.056361  
 8.413733  
 9.868901  
 11.339584  
 12.683188  
 14.081810  
 15.427231  
 16.765920  
 18.084034  
 19.352418  
 20.551604  
 21.696811  
 22.822947  
 23.909606  
 24.886070  
 25.816309  
 26.703978  
 27.457425  
 28.134679  
 28.808461  
 29.331178  
 29.759924  
 30.121481  
 30.337319  
 30.428585  
 30.451153

INPUT VALUES FOR THE RESCALED  
 DEPENDENT VARIABLE ARE:

-2.301919  
 -1.182476  
 .021419  
 1.229633  
 2.428631  
 3.683678  
 4.914793  
 6.199873  
 7.392490  
 8.671032  
 9.943204  
 11.143726  
 12.372586  
 13.554702  
 14.730903  
 15.889027  
 17.003457  
 18.057088  
 19.063292  
 20.052739  
 21.007502  
 21.865444  
 22.682772  
 23.462698  
 24.124692  
 24.719743  
 25.311742  
 25.771013  
 26.147718  
 26.465390  
 26.655031  
 26.735228

(FIGURE 11)

4.50C1C4	30.290526	26.763834
4.714659	30.086933	26.613917
4.851870	29.720280	26.435035
5.120504	29.245163	26.112887
5.289023	28.605864	25.713011
5.510566	27.801352	25.133736
5.727967	26.870283	24.426874
5.898746	25.816004	23.600817
6.040109	24.571545	22.682504
6.273952	23.164626	21.589095
6.511856	21.602654	20.352946
6.720091	19.837725	18.980564
6.924614	17.931619	17.429858
7.076069	15.840806	15.755111
7.334789	13.541443	13.918078
7.455792	11.074376	11.897808
7.713787	8.370135	9.730188
		7.354184

INITIAL ESTIMATES FOR THE COEFFICIENTS ARE:

10.543042
6.147389
1.179282
0.087342

(FIGURE 12)

THE CORRECTIONS TO THE COEFFICIENTS  
 AFTER ITERATION 1 ARE:

-.142306  
 -.004044  
 .035506  
 -.005525

THE VALUES OF THE COEFFICIENTS  
 AFTER ITERATION 1 ARE:

10.420756  
 6.143345  
 -.143776  
 -.092067

THE CORRECTIONS TO THE COEFFICIENTS  
 AFTER ITERATION 2 ARE:

.140795  
 .002041  
 -.034465  
 .005489

THE VALUES OF THE COEFFICIENTS  
 AFTER ITERATION 2 ARE:

10.561551  
 6.145385  
 -.178241  
 -.087378

THE CORRECTIONS TO THE COEFFICIENTS  
 AFTER ITERATION 3 ARE:

-.005163  
 .002036  
 .001037  
 -.000249

THE VALUES OF THE COEFFICIENTS  
 AFTER ITERATION 3 ARE:

10.556387  
 6.147421  
 -.177204  
 -.087627

THE CORRECTIONS TO THE COEFFICIENTS  
 AFTER ITERATION 4 ARE:

-.000784  
 -.000204  
 .000302  
 -.000047

THE VALUES OF THE COEFFICIENTS  
 AFTER ITERATION 4 ARE:

10.555603  
 6.147217  
 -.176902  
 -.087674

THE CORRECTIONS TO THE COEFFICIENTS  
 AFTER ITERATION 5 ARE:

-.000002  
 -.000000  
 .000001  
 -.000000

THE VALUES OF THE COEFFICIENTS  
 AFTER ITERATION 5 ARE:

10.555602  
 6.147217  
 -.176901  
 -.087674

(FIGURE 13)

THE VALUES OF THE SCALED INDEPENDENT VARIABLE ARE:      THE RESIDUALS OF THE SCALED INDEPENDENT VARIABLE ARE:      THE VALUES OF THE SCALED DEPENDENT VARIABLE ARE:      THE RESIDUALS OF THE SCALED DEPENDENT VARIABLE ARE:

-2.076650	-.003502	-2.620616	.006697
-1.903022	.019822	-1.341986	-.003845
-1.700915	-.012377	.022025	.002352
-1.500650	-.005705	1.398435	.001067
-1.304204	.020584	2.767939	-.003803
-1.102147	-.004477	4.191744	.000820
-.905317	-.026913	5.588854	.004839
-.699080	.011478	7.058446	-.002085
-.508892	.003670	8.414401	.000667
-.304651	-.013231	9.866484	.002417
-.094563	-.017124	11.334430	.003154
.096811	.032132	12.689174	-.005985
.298731	.007549	14.083238	-.001428
.496102	-.021823	15.423026	.004205
.698546	.015040	16.766884	-.002966
.900621	-.026089	18.078746	.005288
1.103033	.000894	19.362231	.00108
1.300349	.000759	20.551769	-.000165
1.497117	.023723	21.702181	.005370
1.697787	.002627	22.823572	-.000624
1.901332	-.027732	23.902269	.006977
2.098064	-.004209	24.884942	-.001128
2.292841	.001483	25.816736	-.000428
2.502174	-.024336	26.696317	.007662
2.699064	.032854	27.468838	-.011413
2.891214	.032556	28.147344	-.012635
3.106786	.013503	28.814585	-.006124
3.302273	-.004217	29.328904	.002274
3.503467	.004875	29.763228	-.003304
3.722617	-.000514	30.120987	.000494
3.892595	-.017612	30.311772	.025547
4.090819	.001497	30.434309	-.005714
4.309129	.004992	30.439414	.021740
4.516198	-.016094	30.312994	-.022468
4.706271	.008388	30.075827	.007106
4.890163	-.038293	29.743552	-.023272
5.089758	.030748	29.350980	.014183
5.293211	-.004188	28.607404	-.001540
5.500784	.009782	27.98389	.002963
5.701734	.026233	26.863530	.006754
5.835654	.003092	25.815311	.000493
6.095181	.0055071	24.582387	-.010842
6.297332	-.023380	23.166713	-.00087
6.497558	.014298	21.600412	.002243
6.700527	.019564	19.834953	.002772
6.899440	.025174	17.928368	.003251
7.098259	-.022190	15.843432	-.002626
7.300182	.034606	13.537675	.003768
7.498886	-.043094	11.078718	.004342
7.701746	.012040	8.369010	.001125

(FIGURE 14)

THE ESTIMATED MEAN VALUES OF THE RESIDUALS OF THE SCALED INDEPENDENT AND  
DEPENDENT VARIABLES, RESP., ARE:

.000000

AND

.000000

THE ESTIMATED VARIANCES OF THE SCALED INDEPENDENT AND  
DEPENDENT VARIABLES, RESP., ARE:

.000440

AND

.000069

ASSUMING EQUAL VARIANCES AMONG ALL VARIABLES, THE ESTIMATED TOTAL VARIANCE IS:

.000252

THE POLYNOMIAL RELATIONSHIP WHICH RELATES VEL. (FT/SEC) AS A FUNCTION OF TIME (SEC) IS:

12.0138 + 6.9244 T - .2013 T<sup>2</sup> - .0998 T<sup>3</sup>

(FIGURE 15)

CONVERGENCE PROGRAM FOR 2-DIMENSIONAL DATA  
 HAVING ERRORS ON BOTH THE DEPENDENT AND THE  
 INDEPENDENT VARIABLES.

THE VARIABLES ARE CONNECTED BY A POLYNOMIAL OF DEGREE 3, USING THE METHOD  
 OF STEEPEST DESCENT. THE CONVERGENCE CRITERIA IS THE MINIMIZATION OF THE  
 CORRECTIONS TO THE INDEPENDENT VARIABLE AND THE COEFFICIENTS OF THE CONNECTING  
 POLYNOMIAL, ASSUMING EQUAL VARIANCES FOR EACH DEPENDENT AND INDEPENDENT  
 VARIABLE, AND MUTUAL INDEPENDENCE AMONG ALL MEASUREMENTS FOR BOTH VARIABLES.

THE PROGRAM WILL STOP AFTER 10 ITERATIONS OR AFTER A CHANGE TO THE  
 POLYNOMIAL COEFFICIENTS IS LESS THAN .00005000

THE PROGRAM IS USING 20 ITEMS OF DATA.

INPUT VALUES FOR THE IN-  
 DEPENDENT VARIABLE ARE:

18.200000  
 19.700000  
 39.400000  
 59.100000  
 78.800000  
 98.500000  
 118.200000  
 137.900000  
 157.600000  
 177.300000  
 197.000000  
 216.700000  
 236.400000  
 256.100000  
 275.800000  
 295.500000  
 315.200000  
 334.900000  
 354.600000  
 374.300000  
 394.000000  
 413.700000  
 433.400000  
 453.100000  
 472.800000  
 492.500000  
 512.200000  
 524.200000

INPUT VALUES FOR THE  
 DEPENDENT VARIABLE ARE:

326.300000  
 325.800000  
 320.300000  
 314.000000  
 308.500000  
 302.200000  
 296.900000  
 291.600000  
 286.200000  
 281.600000  
 276.500000  
 271.300000  
 267.000000  
 262.900000  
 257.900000  
 254.200000  
 250.200000  
 246.000000  
 242.300000  
 238.600000  
 234.800000  
 231.300000  
 228.200000  
 224.700000  
 221.400000  
 218.700000  
 215.700000  
 213.700000

INPUT VALUES FOR THE RESCALED

DEPENDENT VARIABLE ARE:

326.300000  
 325.800000  
 320.300000  
 314.000000  
 308.500000  
 302.200000  
 296.900000  
 291.600000  
 286.200000  
 281.600000  
 276.500000  
 271.300000  
 267.000000  
 262.900000  
 257.900000  
 254.200000  
 250.200000  
 246.000000  
 242.300000  
 238.600000  
 234.800000  
 231.300000  
 228.200000  
 224.700000  
 221.400000  
 218.700000  
 215.700000  
 213.700000

(FIGURE 16)



INITIAL ESTIMATES FOR THE COEFFICIENTS ARE:

332.364638  
+.325087  
+.000222  
+.000000

THE VALUES OF THE COEFFICIENTS  
AFTER ITERATION 1 ARE:

332.368375  
+.325160  
+.000223  
+.000000

THE CORRECTIONS TO THE COEFFICIENTS  
AFTER ITERATION 1 ARE:

+.000736  
+.000073  
+.000000  
+.000000

THE VALUES OF THE COEFFICIENTS  
AFTER ITERATION 2 ARE:

332.367603  
+.325148  
+.000223  
+.000000

THE CORRECTIONS TO THE COEFFICIENTS  
AFTER ITERATION 2 ARE:

+.000771  
+.000012  
+.000000  
+.000000

THE VALUES OF THE COEFFICIENTS  
AFTER ITERATION 3 ARE:

332.367604  
+.325148  
+.000223  
+.000000

THE CORRECTIONS TO THE COEFFICIENTS  
AFTER ITERATION 3 ARE:

+.000001  
+.000000  
+.000000  
+.000000

(FIGURE 17)

FIGURE 17

THE VALUES OF THE COEFFICIENTS  
AFTER ITERATION 1 ARE:  
332.368375  
+.325160  
+.000223  
+.000000

THE VALUES OF THE  
SCALED INDEPENDENT  
VARIABLE ARE:

THE RESIDUALS OF THE  
SCALED INDEPENDENT  
VARIABLE ARE:

THE VALUES OF THE  
SCALED DEPENDENT  
VARIABLE ARE:

THE RESIDUALS OF THE  
SCALED DEPENDENT  
VARIABLE ARE:

358.123910	-1.261166	4583.787285	-2.847784
387.673540	-1.399031	4577.085658	-3.165678
770.333639	2.215381	4491.554576	5.150672
1158.367783	4.55747	4407.169853	1.089428
1542.973349	2.124690	4325.822479	5.222070
1932.598283	-1.225734	4245.698094	-3.099512
2317.840360	-0.193301	4168.694537	-0.502879
2703.890710	0.30859	4093.702114	0.082620
3091.155228	-0.959149	4020.617703	-2.643798
3475.343139	1.127449	3950.194719	3.199591
3862.565884	-1.79212	3881.271305	-5.23890
4250.813508	-1.793900	3814.195992	-5.403817
4635.694762	-0.400644	3749.667935	-1.243642
5020.387818	1.180810	3687.086235	3.777985
5409.371255	-1.528117	3625.711481	-5.042473
5793.589679	-5.27968	3566.927961	1.796591
6178.567878	-8.24279	3509.674756	2.893626
6566.778548	-0.11881	3454.009729	-0.405325
6952.569882	0.371294	3400.271608	1.388340
7338.810765	4.04921	3348.152357	1.563134
7725.794156	-0.303960	3297.576883	-1.211752
8112.119996	-0.355290	3248.693390	-1.462907
8497.514923	-5.24292	3201.477504	2.229946
8884.544248	-0.230522	3155.585916	-1.013112
9271.241754	0.653519	3111.212097	2.968132
9656.457925	4.04820	3068.436468	1.900082
10042.870038	2.67217	3026.224979	1.296444
10288.458017	-0.222723	3001.246948	-1.103609

(FIGURE 18)

THE POLYNOMIAL RELATIONSHIP WHICH RELATES VELOCITY AS A FUNCTION OF TIME SPAN IS:

$$4.666-1238 \dots -2328 T \dots +0000 T^2 \dots +0000 T^3$$

# THE PROBABILITY OF MOTOR CASE RUPTURE

RONALD S. DOWNS  
PAUL C. COX

QUALITY ASSURANCE OFFICE  
US ARMY WHITE SANDS MISSILE RANGE  
WHITE SANDS MISSILE RANGE, NEW MEXICO

## A B S T R A C T

Statistical Procedures are studied for the evaluation of the probability that a motor case may rupture as a result of excessive pressures exerted by the propellant. Normally, this study is based upon two sets of data. The first consists of data indicating the pressure required to burst a motor case (X), and the second consists of data indicating the maximum pressure exerted by the motor (Y). These data are obtained from two separate tests; the sample sizes for each test are usually different; and while X is usually tested under a fixed set of conditions, Y is frequently tested under a variety of environmental conditions and therefore makes use of a designed experiment. This may be recognized as a special case of the problem of estimating component reliability from sample measurements taken of the stresses applied and the strength of the component.

Four techniques were studied for the evaluation of the probability of motor case rupture. All required independence for X and Y; the first requires normality for (X-Y), the second requires normality for X and Y, and the third and fourth require few assumptions concerning the distribution of X or Y. The procedures are:

1. One-Sided Statistical Tolerance Limits.
2. The Church-Harris-Downton (CHD) Procedure.
3. Birnbaum - McCarty Procedures.
4. The Chebycheff Inequality.

The last two methods either provide unacceptable results or require an unacceptably large sample size. Either of the first two methods can provide acceptable results with a reasonable sample size if the assumptions of normality can be considered valid. Of these first two, the CHD method appears to give the narrower confidence limits, but the tolerance limit method may be preferable for small samples.

Actual test data was used to test the assumptions underlying the various methods. From this data, it was concluded that X may be distributed almost as the normal, but there is some evidence that Y and (X-Y) may deviate from normality. The implications of these deviations are discussed.

## THE PROBABILITY OF MOTOR CASE RUPTURE

### 1. INTRODUCTION.

a. An important problem when evaluating the safety of a missile or rocket system is the determination, at a suitable level of confidence, that the probability of the motor case rupturing is less than some pre-determined small value. Normally, an estimate of the probability of case rupture will be obtained from two tests, each limited to relatively small samples. The first test will be to determine the maximum pressure (Y) exerted by the motor. The second test will be to determine the pressure (X) required to burst the motor case. The maximum pressure tests will frequently be conducted under a variety of environmental conditions and will, therefore, make use of a designed experiment, while the motor case tests will nearly always be conducted under a fixed set of environmental conditions. The first point is mentioned, because, for most maximum pressure tests, the degrees of freedom cannot be expected to be one less than the sample size.

b. The case rupture problem is a special case of the well-known problem in which the reliability of a component is estimated by determining the probability that the strength (X) of the component exceeds the stresses (Y) which are exerted on the component. The main difference lies in the fact that the examples and supporting data of this report will be related entirely to the motor case problem.

c. The following methods for solving this problem are discussed:

- (1) The Statistical Tolerance Limits.
- (2) Church-Harris-Downton (CHD) Procedure.
- (3) Birnbaum - McCarty Procedure.
- (4) The Chebycheff Inequality.

The advantages and disadvantages of each procedure is discussed and actual test data is used to evaluate the assumptions of these procedures.

## 2. STATISTICAL TOLERANCE LIMITS.

a. A procedure which has been used for some time for the solution of case rupture problems has been that of statistical tolerance limits. If it can be shown, at the  $\gamma\%$  level of confidence, that  $(X-Y) < 0$  no more than  $\epsilon\%$  of the time, then it is clear that at the  $\gamma\%$  level of confidence, the probability of case rupture does not exceed  $\epsilon\%$ . Making use of a table of one-sided normal, tolerance limits, such as Reference a, this can be determined if:

- (1)  $X-Y$  is normally distributed
- (2)  $\overline{X-Y}$  is known
- (3)  $n_{x-y}$  can be determined
- (4)  $S_{x-y}$  can be determined
- (5) Degrees of Freedom:  $f_{x-y}$  can be determined

b. If the assumption of normality is valid, the required information is available from the following formulae:

$$(1) \quad \overline{X-Y} = \overline{X} - \overline{Y} \quad F(1)$$

$$(2) \quad S_{x-y}^2 = S_x^2 + S_y^2 \quad F(2)$$

$$(3) \quad n_{x-y} = \frac{S_x^2 + S_y^2}{\frac{S_x^2}{n_x} + \frac{S_y^2}{n_y}} \quad F(3)$$

(Note Appendix 2 for discussion)

$$(4) \quad f_{x-y} = \frac{(S_x^2 + S_y^2)^2}{\frac{S_x^4}{f_x+2} + \frac{S_y^4}{f_y+2}} - 2 \quad F(4)$$

(Note Reference b)

c. Referring to Example A, Appendix 1, the following can be computed:

$$(1) \quad \bar{X} - \bar{Y} = 2500$$

$$(2) \quad S_{x-y} = \sqrt{(250)^2 + (450)^2} = 514.78$$

$$(3) \quad (\bar{X} - \bar{Y}) / S_{x-y} = 4.856$$

$$(4) \quad n_{x-y} = 9.22$$

$$(5) \quad f_{x-y} = 14.31$$

d. Referring to pages 180 and 182 of Reference a, and performing several interpolations, it can be determined that at the 90% level of confidence, the probability of a case rupture does not exceed  $3.30 \times 10^{-4}$ .

e. Formulas F(3) and F(4) frequently provide fractional answers. One may proceed by rounding the fractions to the nearest integers and computing the desired probability, or the fractions can be retained and the solution can involve extensive interpolation.

f. Advantages.

(1) At a given level of confidence, low probabilities of case rupture can be obtained with relatively small samples.

(2) If suitable tolerance limits tables are available, the procedure is relatively simple to apply (especially simple if  $f$  and  $n$  are integers).

g. Disadvantages.

(1) The procedure is sensitive to deviations from normality.

(2) As will be shown in Section 3, the Church-Harris-Downton procedure generally provides lower probabilities of case rupture than the tolerance limit procedure.

### 3. THE CHURCH-HARRIS-DOWNTON (CHD) PROCEDURE.

a. The Church-Harris-Downton (CHD) Procedure evolved through three journal articles, References c through e, and was developed to determine, at a suitable level of confidence, the probability that  $X > Y$ . It was specifically developed to evaluate the reliability of a component based upon its strength and the stresses it must undergo.

(1) The confidence limit statement:

$$P_r \{ \Phi[V - \Phi^{-1}(1-\alpha/2)\hat{\sigma}_V] < R < \Phi[V + \Phi^{-1}(1-\alpha/2)\hat{\sigma}_V] \} = 1-\alpha \quad F(5)$$

$$(2) \quad V = \frac{\bar{X} - \bar{Y}}{\sqrt{C_n S_x^2 + C_m S_y^2}}; \quad \Phi(V) = \hat{R} \text{ (the point estimate)} \quad F(6)$$

$$(3) \quad \sigma_V^2 = \frac{1}{C_n S_x^2 + C_m S_y^2} \left[ \frac{S_x^2}{n_x} + \frac{S_y^2}{n_y} + \frac{(\bar{X} - \bar{Y})^2 \left( \frac{C_n^2 \cdot S_x^4}{f_x} + \frac{C_m^2 \cdot S_y^4}{f_y} \right)}{2(C_n S_x^2 + C_m S_y^2)^2} \right] \quad F(7)$$

b. The following explanations of F(5) through F(7) are given:

(1) F(5) is for two-sided confidence limits. For one-sided, replace  $\alpha/2$  with  $\alpha$ .

(2)  $\Phi$  refers to the cumulative normal and  $\Phi^{-1}$  to the inverse cumulative normal. Selected values of  $\Phi^{-1}$  are provided in Appendix 3.

(3)  $C_n$  is a constant depending upon  $n_x$  and  $C_m$  on  $n_y$ . These constants were developed by Dr. F. Downton, Reference 3, and may be found in Appendix 3. The constants could be replaced by one without greatly affecting the results.

c. To solve Example A, Appendix 1, by the CHD Method:

$$(1) \quad V = 5.01922 \text{ and } \sigma_V = \sqrt{1.0754} = 1.037 .$$

(2) For 90%, one-sided confidence limits,  $\phi^{-1}(1-\alpha) = 1.28155$ .

(3)  $P_r\{\phi[5.019 - 1.282 \times 1.037] < R\} = 90\%$

$P_r\{\phi(3.690) < R\} = 90\%$

$P_r\{.999888 < R\} = 90\%$

90% confidence that the probability of case rupture  $< 1.12 \times 10^{-4}$ .

d. Advantages.

(1) At a given level of confidence, low probabilities of case rupture can be obtained with relatively small samples. The CHD method generally appears to provide narrower confidence limits than the tolerance limit method. Paragraph 2 of Appendix 1 gives the results for five examples and it can be seen that in each case the CHD method gives probabilities ranging from 1/2 to 1/3 of those obtained by the tolerance limit method.

(2) Aside from the complexity of Formula F(7), the CHD method is relatively simple to use. About the only tables required are Tables of  $C_n$  and good tables of the cumulative normal.

e. Disadvantages.

(1) The CHD method is sensitive to deviations from normality.

(2) The CHD method uses the asymptotic normal approximation of a given statistic, and requires substitution of the population means and standard deviations by their observed sample values. For these reasons, the method of statistical tolerance limits may be preferable when dealing with small samples.

4. BIRNBAUM - McCARTY STATISTICS.

a. Birnbaum - McCarty statistics provide a non-parametric procedure for determining, at a given level of confidence, that  $X < Y$ . This procedure is relatively simple and involves computing  $\hat{\beta} = U/(n_x \cdot n_y)$ , where  $U$  is the number of pairs of  $x$  and  $y$  for which  $x < y$ . It is then possible to make the following statement:



$P_r\{p \leq \hat{p} + \epsilon\} \geq \gamma$ , where  $\epsilon$  depends upon  $n_x$ ,  $n_y$ , and  $\gamma$ , and can be obtained from the Tables on pages 323 and 324 of Reference f.

b. To illustrate this procedure, Example A of Appendix 1, will again be used. It will be assumed that the smallest  $x$  in the sample is larger than the largest  $y$ , resulting in  $U = \hat{p} = 0$ . From page 323 of Reference f, it can be seen that  $\epsilon = 0.609$  for  $n_x = 10$ ,  $n_y = 9$ , and  $\gamma = 90\%$ . Thus,  $P_r [(Y < X) < .609] \geq 90\%$ , which is to say that at the 90% level of confidence, the probability of case rupture is less than 60.9%. (Note Para 2, Appendix 1, for other examples.)

c. It is of further interest that if Birnbaum - McCarty statistics were used to verify, at the 90% level of confidence, that the probability of case rupture did not exceed .005, it would require  $n_x = n_y = 140,111$ .

d. Advantages. The only requirement is that  $X$  and  $Y$  must be independent random variables.

e. Disadvantages.

(1) To provide probabilities which are at all useful, completely unrealistic sample sizes are required.

(2) Regardless of how widely separated  $\bar{X}$  and  $\bar{Y}$  may be, as long as the two samples do not overlap, it does not improve the probabilities.

## 5. THE CHEBYCHEFF INEQUALITY.

a. Since Birnbaum - McCarty statistics do not appear to provide a reasonable solution for the motor case problem, the Chebycheff Inequality is offered as a possible procedure when there is reason to believe that the assumption of normality may not be valid.

b. This procedure is discussed below, and Example A is again used to illustrate the method.

(1) To Chebycheff Inequality is given by F(8) and F(9) below. The procedure for converting the inequality from a well known form to F(8) is provided by Appendix IV.

$$P(X>Y) \geq 1 - 1/K^2 \quad F(8)$$

$$K = \frac{\mu_x - \mu_y}{\sqrt{\sigma_x^2 + \sigma_y^2}} \quad F(9)$$

(2) Using the data for Example A from Appendix 1, and the values  $n_{x-y} = 9.22$  and  $f_{x-y} = 16.31$  from Para 2c, the following is determined:

(a) 95% LCL for  $\mu_x - \mu_y$ :

$$\bar{X} - \bar{Y} - t_{.95, 16.31} \sqrt{\frac{S_x^2 + S_y^2}{n_{x-y}}} = 2500 - (1.7439)(82.333) = 2356.642$$

(b) 95% UCL for  $\sigma_{x-y}$ :

$$\sqrt{\frac{f(S_x^2 + S_y^2)}{\chi_{.95, f}^2}} = \sqrt{\frac{16.308 \cdot 265,000}{8.181}} = 726.809$$

(c) 90% LCL for  $K = \frac{2356.642}{726.809} = 3.242$

(d) 90% LCL for Prob  $(Y < X) = 1 - 1/K^2 = 1 - 1/(3.242)^2 = 1 - .0951 = .905$ .

(e) Assuming  $(X-Y)$  is continuous, unimodal, and symmetric, 90% LCL for Prob  $(Y < X) = 1 - 2/9K^2 = 1 - .0211 = .979$

c. Advantages.

(1) Except for the application of  $t$  and  $\chi^2$  tests, the procedure is completely distribution free.

(2) The procedure is relatively simple to apply.

(3) Referring to the Table in Para 2 of Appendix 1, it appears that the Chebycheff procedure provides better results than Birnbaum - McCarty, and if  $(X-Y)$  is continuous, unimodal, and symmetric, it is possible to improve even more.

d. Disadvantages.

(1) The  $t$  and  $\chi^2$  procedures are based upon the assumption of normality.

(2) While the results are better than Birnbaum - McCarty, they are still not adequate for most applications.

(3) If it is desired to use the further refinement of continuity, unimodal, and symmetry, this will be about as difficult to verify as normality, and it really doesn't buy nearly as much as the assumption of normality.

6. OTHER PROCEDURES. The four methods determining motor safety, which are discussed in this report, are far from exhaustive. Three additional methods are briefly discussed below:

a. Reference m uses the Chebycheff inequality and the Van Dantzig upper bound for the variance of the Mann-Whitney statistic  $U$  to provide distribution free confidence intervals for the probability ( $Y < X$ ). This method generally gives better results than Birnbaum-McCarty statistics but not as good as the Chebycheff procedures of Section 5 of this report.

b. Paragraph 4 of Reference j provides a procedure which can be used if  $X$  and  $Y$  are independent and both are normally distributed. This method provides results which are about the same as the Tolerance Limit Method, but has the following limitations:

(1)  $\sigma_x$  and  $\sigma_y$  must be equal.

(2)  $n_x$  and  $n_y$  must be equal.

(3) The published tables do not go below 10 or above 100 for sample size.

(4) The published tables do not provide probabilities of less than one percent.

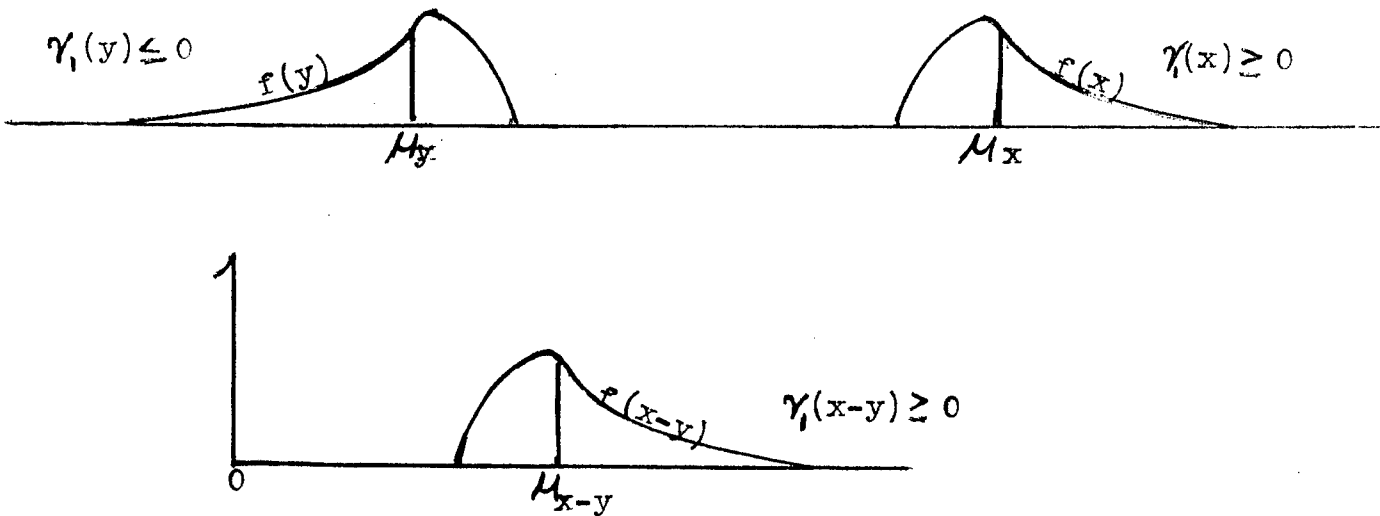
c. Reference l provides procedures based upon similar concepts to those discussed in 6b and provides some additional methods for solving the case rupture problem.

7. TEST FOR NORMALITY.

a. The methods of "Statistical Tolerance Limits" and "Church-Harris-Downton" are both based upon the assumptions of independence and normality. The assumption of independence for X and Y appears to be perfectly reasonable, but the assumption of normality requires careful study. If X and Y are both normal and independent, then X-Y is also normal with  $\mu_{x-y} = \mu_x - \mu_y$  and  $\sigma_{x-y}^2 = \sigma_x^2 + \sigma_y^2$ . Therefore, the matter of normality for X, Y, and X-Y will all be investigated.

b. In addition to testing for normality, it may also be useful to compute the coefficients of skewness ( $\gamma_1$ ) and kurtosis ( $\gamma_2$ ).

(1) The following drawings illustrate why the distributions of X and Y appear less likely to overlap if  $\gamma_1(X)$  is positive and  $\gamma_1(Y)$  is negative. Similarly, the distribution of (X-Y) appears less likely to overlap zero if  $\gamma_1(X-Y)$  is positive.



(2) Kurtosis: If the coefficients of kurtosis ( $\gamma_2$ ) for X and Y are both negative, there appears to be less likelihood of their distributions overlapping, than if  $\gamma_2$  is either zero or positive. Furthermore, if  $\gamma_2$  is negative, a narrower confidence limit for the variance can be expected than if  $\gamma_2$  is zero or positive. Note pages 51-56 of Reference h.

c. Actual Test Data.

(1) A search was made for actual test data, and while all the data that was located was classified, burst pressure data (X) was located from three tests and maximum generated pressure data (Y) was located from 20 tests. Table 1 provides: sample size; the coefficient of skewness ( $\gamma_1$ ); the coefficient of kurtosis ( $\gamma_2$ ); and the significance level using the Shapiro-Wilk procedure to test for deviations from normality. (Note Reference i for a discussion of the Shapiro-Wilk Test.)

(2) From Table 1:

(a) Burst Pressure Data.

1. Neither  $\gamma_1$  nor  $\gamma_2$  is significantly different from zero for any of the three tests.

2.  $\gamma_1$  is small in all cases and positive for two.

3.  $\gamma_2$  is negative for all three tests.

4. The Shapiro-Wilk test gives no indication of deviation from normality.

5. For burst pressure, the assumption of normality appears reasonable.

(b) Maximum Generated Pressure.

1. For Test #5,  $\gamma_1$  is significantly different from zero at the 5% level and  $\gamma_2$  at the 1% level. Neither  $\gamma_1$  nor  $\gamma_2$  is significantly different from zero for any of the other 19 tests.

2. From the Shapiro-Wilk Test, #5 deviated significantly from normality at the 1% level while tests 11 and 14 showed deviation at the 10% level. For the other 17 tests, there was no indication of a significant deviation.

3. The signs for  $\gamma_1$  and  $\gamma_2$  are about evenly divided between positive and negative. <sup>1</sup>

4. There is little indication that (Y) data deviates significantly from normality, but there is enough questionable data that further study appears desirable.

TABLE 1

PROPERTIES OF 3 SAMPLES FOR BURST PRESSURE (X)  
AND 20 SAMPLES FOR MAXIMUM GENERATED PRESSURE (Y)

TYPE OF TEST	TEST NO.	SAMPLE SIZE	$\gamma_1$	$\gamma_2$	SHAPIRO-WILK TEST
BURST PRESSURE (X)	1	7	-0.070	-1.193	.90
	2	10	0.162	-0.284	.50
	3	10	0.118	-0.505	.98
MAX GEN PRESSURE (Y)	1	7	-0.86	0.723	.27
	2	8	-0.17	0.162	.61
	3	12	0.088	-1.124	.27
	4	12	0.681	0.245	.40
	5	10	-1.849**	5.263***	.01***
	6	12	0.285	-1.330	.35
	7	10	-0.394	-1.502	.27
	8	4	0.840	2.289	.36
	9	5	0.992	2.861	.32
	10	6	1.053	2.727	.34
	11	5	0.405	-3.034	.09*
	12	6	0.145	-0.908	.98
	13	6	0.447	0.454	.59
	14	4	1.047	3.484	.08*
	15	4	0.317	-0.849	.81
	16	4	-0.771	1.916	.42
	17	4	0.000	1.500	.57
	18	8	-0.331	1.634	.75
	19	6	0.088	-1.900	.57
	20	6	-0.105	-1.900	.25

\*Significance at 10% level.

\*\*Significance at 5% level.

\*\*\*Significance at 1% level.

(3) The small samples associated with the tests in Table 1 provide a serious handicap in evaluating normality. Therefore, the following was performed in an attempt to obtain a look at a larger sample:

(a) The data from the three "burst pressure" samples were transformed to provide samples with  $\bar{X}=0$  and  $S_x=1$ . The data was then combined to form a single sample with  $n = 27$ ,  $\bar{X} \approx 0$ , and  $S_x \approx 1$ .

(b) The data from the 20 "maximum generated pressure" samples were transformed to provide samples with  $\bar{Y} = 0$  and  $S_y = 1$ . The data was then combined to form a single sample with  $n = 139$ ,  $\bar{Y} \approx 0$ , and  $S_y \approx 1$ .

(c) The data discussed in Para (a) was again transformed such that  $\bar{X} = 4000$  and  $S = 300$ . The data in Para (b) was transformed to have  $\bar{Y} = 2000$  and  $S = 75$ . Then a sample of 200 values of X-Y was obtained by randomly matching values of X and Y and computing their differences.

(d) The sample size, mean, standard deviation, coefficient of skewness, coefficient of kurtosis, their standard deviations, and normality test information are provided in Table 2 for the combined samples of X, Y, and (X-Y).

TABLE 2

PROPERTIES OF SIMULATED SAMPLES FOR BURST PRESSURE (X),  
MAXIMUM GENERATED PRESSURE (Y), AND (X-Y)

TYPE OF DATA	SAMPLE SIZE	MEAN	ST. DEV.	$\gamma_1$	$S\gamma_1$	$\gamma_2$	$S\gamma_2$	TEST FOR NORMALITY <sup>1</sup>
X	27	.0002	0.961	.0887	.471	-.0811	.578	.43
Y	139	.0008	0.923	-.124	.208	-.568	.408	.11
X-Y	200	2026	287	-.004	.172	-.978***	.342	.025**

\*\*Significant at the 5% level.

\*\*\*Significant at the 1% level.

<sup>1</sup>The Shapiro-Wilk Test was used to test for normality of X. The  $\chi^2$  test was used to test for normality of Y and X-Y.

(4) It is possible that the procedures introduced in developing the samples of Table 2 may have introduced some biases in the above statistics, but the following may be drawn from this Table.

(a) Burst Pressure Data (X)

1. Both  $\gamma_1$  and  $\gamma_2$  are small and have the desired sign.

2. The Shapiro-Wilk Test indicates no significant deviation from normality.

3. The assumption of normality appears to be valid.

(b) Maximum Generated Pressure (Y)

1.  $\gamma_1$  is small and possesses the desired sign.

2.  $\gamma_2$  differs from zero at about the 17% level of significance.  $\gamma_2$  possesses the desired sign if not zero.

3. Y deviates from normality at the 11% level of significance, using the  $\chi^2$  test for goodness of fit.

4. While  $\gamma_1$  and  $\gamma_2$  possess the desired signs, there remains some concern about the assumption of normality and the behavior of the distribution in the region of the tails. Fortunately, the variance of Y is usually significantly smaller than the variance for X.

(c) (X-Y)

1.  $\gamma_1$  is essentially zero.

2.  $\gamma_2$  is large and differs from zero at the 1% level of significance. This may reflect the procedure used instead of the behavior of the distribution of (X-Y). Fortunately,  $\gamma_2$  is negative.

3. Using the  $\chi^2$  test for goodness of fit, (X-Y) deviates from normality at the 2 1/2% level of significance. This can be attributed to the large negative value of  $\gamma_2$ .



4. There may be considerable question concerning the normality for  $(X-Y)$ , especially since normality for  $Y$  is questionable. This apparent lack of normality appears to be caused by the large, negative value for the coefficient of kurtosis, and this may be caused by the procedure for constructing the sample rather than the actual behavior of  $(X-Y)$ . While a negative value for the coefficient of kurtosis may be preferable to a positive value, there still remains the question of the behavior of the distribution in the vicinity of the tails.

## 8. CONCLUSIONS.

a. Birnbaum-McCarty and Chebycheff Inequality procedures are desirable because of their distribution free characteristics. However, each provides either unsatisfactory confidence limits or requires unrealistic sample sizes.

b. Both the statistical tolerance limits and the Church-Harris-Downton methods require assumptions of independence for  $X$  and  $Y$  and normality for each. If the above assumptions are valid, either can be expected to provide satisfactory confidence limits with a reasonable sample. Of the two, the Church-Harris-Downton method appears to provide narrower confidence limits, but may be less suitable for small samples.

c. A study of actual data suggests:

(1) The assumption of normality appears to be reasonable for pressure required to burst the case  $(X)$ .

(2) The assumption of normality may be questionable for the maximum pressure  $(Y)$  and the difference  $(X-Y)$  thus suggesting considerable caution when applying these procedures.

## 9. REFERENCES.

a. Owen, D. B., "Factors for One-Sided Tolerance Limits and For Variable Sampling Plans." SCR-607, March 1963, the Sandia Corporation. Available from the Office of Technical Services, Dept of Commerce, Washington, DC.

b. Welch, B. A., "The Generalization of Student's Problem When Several Different Population Variances are Involved," *Biometrika*, VOL 34, 1947, p. 28-35.

- c. Church, J. D. and Harris, Bernard, "Estimates of  $P(Y < X)$  and Their Application to Reliability Problems for Both Continuous and Quantal Response Data," proceedings of the 13th Conference on the Design of Experiments, 1967.
- d. Church, J. D. and Harris, Bernard, "The Estimation of Reliability from Stress-Strength Relationships," Technometrics, VOL 12, February 1970, p. 49.
- e. Downton, F., "The Estimation of  $\Pr(Y < X)$  in the Normal Case," Technometrics, VOL 15, August 1973, p. 551.
- f. Owen, D. B., "Handbook of Statistical Tables," 1962, Addison-Wesley Publishing Co., Inc., Reading, Mass.
- g. Box, G. E. P., "Non-Normality and Tests on Variances," Biometrika, VOL 40, 1953, p. 318.
- h. Davies, O. L., "The Design and Analysis of Industrial Experiments," 1963, Oliver and Boyd, London.
- i. Shapiro and Wilk, "An Analysis of Variance Test for Normality," Biometrika, VOL 52, 1965, p. 591-611.
- j. Owen, Craswell, and Hanson, "Nonparametric Upper Confidence Bounds for  $\Pr\{Y < X\}$  and Confidence Bounds for  $\Pr\{Y < X\}$  When X and Y are Normal," Journal of the American Statistical Association, VOL 59, September 1964, p. 906.
- k. Dixon, W. J. and Massey, F. J. Jr., "Introduction to Statistical Analysis," 1957, McGraw-Hill Book Company, Inc., New York.
- l. Mazumdar, M., "Some Estimates of Reliability Using Inference Theory," Naval Research Logistics Quarterly, June 1970, p. 159-165.
- m. Ury, Hans K., "On Distribution-Free Confidence Bounds for  $\Pr\{Y < X\}$ ," Technometrics, August 1972, p. 577-581.

## APPENDIX 1

### EXAMPLES

1. The following examples are used for illustrative and for comparison purposes. Example A is used for demonstrating how the four procedures of this report are applied. Note that for Example A, a designed experiment was used to evaluate the maximum pressure exerted by the propellant, resulting in a sample of 10 with 17 degrees of freedom. In all other examples, the degrees of freedom are (n-1).

PRESSURE REQUIRED  
TO BURST CASE

MAXIMUM PRESSURE  
EXERTED BY PROPELLANT

Example A

$$\bar{X} = 6000 \text{ psi}$$

$$S_x = 450 \text{ psi}$$

$$n_x = 9$$

$$f_x = 8$$

$$\bar{Y} = 3500 \text{ psi}$$

$$S_y = 250 \text{ psi}$$

$$n_y = 10$$

$$f_y = 17$$

Example B

$$\bar{X} = 6000 \text{ psi}$$

$$S_x = 400 \text{ psi}$$

$$n_x = 16$$

$$f_x = 14$$

$$\bar{Y} = 3500 \text{ psi}$$

$$S_y = 400 \text{ psi}$$

$$n_y = 15$$

$$f_y = 14$$

Example C

$$\bar{X} = 6000 \text{ psi}$$

$$S_x = 400 \text{ psi}$$

$$n_x = 10$$

$$f_x = 9$$

$$\bar{Y} = 3500 \text{ psi}$$

$$S_y = 200 \text{ psi}$$

$$n_y = 25$$

$$f_y = 24$$

Example D

$$\bar{X} = 6000 \text{ psi}$$

$$S_x = 450 \text{ psi}$$

$$n_x = 25$$

$$f_x = 24$$

$$\bar{Y} = 3500 \text{ psi}$$

$$S_y = 250 \text{ psi}$$

$$n_y = 10$$

$$f_y = 9$$

Example E

$$\bar{X} = 6000 \text{ psi}$$

$$S_x = 500 \text{ psi}$$

$$n_x = 8$$

$$f_x = 7$$

$$\bar{Y} = 3500 \text{ psi}$$

$$S_y = 125 \text{ psi}$$

$$n_y = 8$$

$$f_y = 7$$

2. The following table provides 90%, one-sided confidence limits that the probability of case rupture will not exceed the listed value for each procedure.

P R O C E D U R E

EXAMPLE	TOLERANCE LIMITS	CHURCH-HARRIS DOWNTON	BIRNBAUM-McCARTY <sup>1</sup>	CHEBYCHEFF INEQUALITY	2/9 × CHEBYCHEFF INEQUALITY <sup>2</sup>
A	$3.30 \times 10^{-4}$	$1.12 \times 10^{-4}$	$6.09 \times 10^{-1}$	$9.51 \times 10^{-2}$	$2.11 \times 10^{-2}$
B	$2.92 \times 10^{-4}$	$1.10 \times 10^{-4}$	$4.83 \times 10^{-1}$	$10.24 \times 10^{-2}$	$2.28 \times 10^{-2}$
C	$2.91 \times 10^{-5}$	$8.54 \times 10^{-6}$	$4.88 \times 10^{-1}$	$8.10 \times 10^{-2}$	$1.80 \times 10^{-2}$
D	$5.05 \times 10^{-5}$	$2.00 \times 10^{-5}$	$4.88 \times 10^{-1}$	$7.86 \times 10^{-2}$	$1.75 \times 10^{-2}$
E	$9.18 \times 10^{-4}$	$4.28 \times 10^{-4}$	$6.62 \times 10^{-1}$	$16.46 \times 10^{-2}$	$3.66 \times 10^{-2}$

<sup>1</sup>When applying the Birnbaum-McCarty procedure, it is assumed that the smallest X in the sample is larger than the largest Y in its sample.

<sup>2</sup>Using 2/9 of the Chebycheff values is justified if (X-Y) is continuous, unimodal, and symmetric.

## APPENDIX 2

### SELECTING THE SAMPLE SIZE FOR THE STATISTICAL TOLERANCE LIMIT METHOD

1. When applying statistical tolerance limits to determine the probability that  $X-Y > 0$ , it is necessary to determine a sample size,  $n_{x-y}$ , to be used in the computation. If  $n_x = n_y$ , then simply set  $n_{x-y} = n_x = n_y$ . If  $n_x \neq n_y$ , a safe procedure is to set  $n_{x-y}$  to the smaller of  $(n_x, n_y)$ . However after some consideration, F(3) was decided upon:

$$n_{x-y} = \frac{S_x^2 + S_y^2}{\frac{S_x^2}{n_x} + \frac{S_y^2}{n_y}} \quad \text{F(3)}$$

2. The procedure used in determining F(3) was as follows:

a. The t test for the equality of two means with unequal variances:

$$t \equiv \frac{(\bar{X} - \bar{Y}) - (\mu_x - \mu_y)}{\sqrt{\frac{S_x^2}{n_x} + \frac{S_y^2}{n_y}}}$$

b. If  $n_x = n_y = n$ , the formula obviously becomes:

$$t = \frac{(\bar{X} - \bar{Y}) - (\mu_x - \mu_y)}{\sqrt{\frac{S_x^2 + S_y^2}{n}}}$$

c. Equating the two and solving for n gives F(3).

3. The above procedure cannot be considered more than a plausible reason for F(3); however, F(3) does have the following desirable attributes:

a. If  $n_x = n_y$ , then  $n_{x-y} = n_x = n_y$ .

b. If  $S_x = S_y$ , then  $n_{x-y}$  is the harmonic mean of  $n_x$  and  $n_y$ .

c.  $n_{x-y}$  is bounded by  $n_x$  and  $n_y$ .

d. If  $S_x > S_y$ , then  $n_{x-y}$  will be closer to  $n_x$  than  $n_y$ , and this is desirable since the larger S has the greater influence on  $S_{x-y}$  in the formula:

$$S_{x-y} = \sqrt{S_x^2 + S_y^2}$$

APPENDIX 3

TABLES REQUIRED FOR THE CHURCH-HARRIS-DOWNTON (CHD) PROCEDURE

1. Values of  $C_n$ , taken from p. 554 of Reference e, are listed below.<sup>1</sup>

n	$C_n$	n	$C_n$	n	$C_n$
4	0.9955	17	0.9560	30	0.9719
5	0.9456	18	0.9578	31	0.9727
6	0.9334	19	0.9595	32	0.9734
7	0.9314	20	0.9610	33	0.9741
8	0.9328	21	0.9625	34	0.9748
9	0.9355	22	0.9638	35	0.9754
10	0.9384	23	0.9651	36	0.9760
11	0.9414	24	0.9663	37	0.9766
12	0.9443	25	0.9674	38	0.9772
13	0.9470	26	0.9684	39	0.9777
14	0.9495	27	0.9694	40	0.9782
15	0.9519	28	0.9703	-	-
16	0.9540	29	0.9711	-	-

For large  $n$ ,  $C_n \sim 1 - 1/n + 6/n^2 - 60/n^3 + O(n^{-4})$ .

<sup>1</sup>This Table has been included with the permission of the author.

2. Values for  $\Phi^{-1}$  (Inverse Cumulative Normal)

CONFIDENCE LEVEL	ONE SIDED	TWO SIDED
0.70	.6745	1.0364
0.80	.8461	1.2816
0.85	1.0364	2.4395
0.90	1.2816	1.6449
0.95	1.6449	1.9600
0.975	1.9600	2.2482
0.99	2.3264	2.5758
0.995	2.5758	2.8130

3. For values of  $\Phi$ , any table of cumulative normal should be adequate. The tables on p. 3-10 and on p.13 of Reference f could be useful since these cover values of  $\Phi$  from 0-500.

4. Using the above,  $V$  and  $\sigma_v$  can easily be computed, note Example A, Appendix 1.

$$a. \quad V = \frac{\bar{X} - \bar{Y}}{\sqrt{\frac{C_x S_x^2}{n_x} + \frac{C_y S_y^2}{m_y}}} = \frac{6000 - 3500}{\sqrt{.9355(450)^2 + .9384(250)^2}} = 5.01922 \quad F(6)$$

$$b. \quad \sigma_v^2 = \frac{1}{\frac{C_x S_x^2}{n_x} + \frac{C_y S_y^2}{m_y}} \left[ \frac{S_x^2}{n_x} + \frac{S_y^2}{m_y} + \frac{(\bar{X} - \bar{Y})^2 \left( \frac{C_x^2 S_x^4}{n_x^2} + \frac{C_y^2 S_y^4}{m_y^2} \right)}{2(C_x S_x^2 + C_y S_y^2)^2} \right] \quad F(7)$$

$$= \frac{1}{(.9355)(450)^2 + (.9384)(250)^2} \left[ \frac{(450)^2}{9} + \frac{(250)^2}{8} + \frac{(2500)^2 \left( \frac{(.9355)^2 (450)^2}{8} + \frac{(.9384)^2 (250)^2}{17} \right)}{2\{(.9355)(350)^2 + (.9384)(250)^2\}^2} \right] = 1.0817$$

$$\sigma_v = 1.0400$$



APPENDIX 4

THE CHEBYCHEFF INEQUALITY

1. The usual statement of the Chebycheff Inequality:

- a.  $P[|Z - \mu_Z| > b] \leq \sigma_Z^2/b^2$
- b.  $P[-b < (Z - \mu_Z) < b] \geq 1 - \sigma_Z^2/b^2$
- c.  $P[(Z - \mu_Z) > -b] \geq 1 - \sigma_Z^2/b^2$

Since the inequality has changed from two-sided to one-sided, it would appear reasonable to write the right side of 1c as  $1 - \sigma^2/2b^2$ ; however, this does not appear to be justified since there is no assurance of symmetry.

2. Letting  $Z = X-Y$ , 1c can be written:

$$a. P\{[(X-Y) - (\mu_X - \mu_Y)] > -(\mu_X - \mu_Y)\} \geq 1 - \frac{\sigma_X^2 + \sigma_Y^2}{(\mu_X - \mu_Y)^2}$$

b. Subtracting  $(\mu_X - \mu_Y)$  from both sides of the inequality within the brackets and letting

$$K = \frac{\mu_X - \mu_Y}{\sqrt{\sigma_X^2 + \sigma_Y^2}} \tag{F(9)}$$

$$P[(X-Y) > 0] \geq 1 - 1/K^2$$

$$c. P(X > Y) \geq 1 - 1/K^2 \text{ or} \tag{F(8)}$$

$$d. P(X < Y) \leq 1/K^2$$

3. According to Reference k, page 293, when  $(X-Y)$  is continuous, unimodal, and symmetric, and since this is a one-sided inequality, 2d could be written:

$$P(X < Y) \leq 2/9K^2$$

ON THE NONEXISTENCE OF SOME  
INCOMPLETE BLOCK DESIGNS

Alan W. Benton  
U. S. Army Materiel Systems Analysis Activity  
Aberdeen Proving Ground, Maryland

ABSTRACT. When considering a randomized complete block design, it may turn out that the blocks available are not large enough to accommodate all of the treatments. We are, thus, naturally lead to the consideration of incomplete block designs (IBD); incomplete in the sense that each block does not contain a complete set of treatments. Although the parameters which define an IBD may satisfy the necessary parametric relations usually used for this purpose, the configuration may not exist. A development of nonexistence proofs, utilizing the Hasse-Minkowski invariant, is presented which leads to some necessary conditions for symmetrical balanced incomplete block designs (SBIBD). Some necessary conditions are worked out for the existence of intra- and inter-group balanced incomplete block designs.

1. INTRODUCTION. In order to pave the background for the formulation of the problem it will be necessary to provide a few definitions.

Let  $v$  denote the number of treatments,  
 $b$  denote the number of blocks,  
 $r$  denote the number of replications of a treatment,  
 $k$  denote the block size, i.e., the number of treatments  
in a block.

An IBD is an arrangement of  $v$  treatments in  $b$  blocks such that no treatment occurs more than once in any block, each treatment occurs in exactly  $r$  blocks and each block contains exactly  $k$  distinct treatments,  $k < v$ . A BIBD is characterized by the parameter  $\lambda$  which indicates the number of times a pair of treatments occurs together in a block. If  $v=b$  then the design is said to be symmetric and this design is denoted by SBIBD.

The five parameters which define a BIBD are not algebraically independent. They are integers subject to the following restrictions:

$$vr = bk \quad (1)$$

$$\lambda(v-1) = r(k-1) \quad (2)$$

With every design is associated a unique (0,1) matrix called the incidence matrix, where 1 and 0 indicate the presence or absence of a treatment in a block, respectively. The matrix for a BIBD is written as

$$N = (n_{ij}), \quad i=1,2,\dots,v \text{ and } j=1,2,\dots,b$$

$$n_{ij} = \begin{cases} 1 & \text{if } V_i \in B_j, \\ 0 & \text{if } V_i \notin B_j, \end{cases}$$

where  $V_1, V_2, \dots, V_v$  are the treatments and  $B_1, B_2, \dots, B_b$  are the blocks.

Of considerable interest in the theory of IBDs is the matrix  $NN'$ , which consists of  $v$  rows and  $v$  columns and provides a description of the treatment structure of the design. For example, for the design  $v=b=3, r=k=2, \lambda=1$

$$N = \begin{bmatrix} 1 & 1 & 0 \\ 1 & 0 & 1 \\ 0 & 1 & 1 \end{bmatrix}$$

and

$$NN' = \begin{bmatrix} 2 & 1 & 1 \\ 1 & 2 & 1 \\ 1 & 1 & 2 \end{bmatrix} = (r-\lambda)I_v + \lambda J_{vv} \quad (3)$$

where  $I_v$  is the identity matrix of order  $v$  and  $J_{vv}$  a matrix of order  $v \times v$  of whose elements are 1.

In the remainder of the text we will make use of the properties of the Legendre symbol  $(b/p)$ , the Hilbert norm residue symbol  $(a,b)_p$ , and the Hasse-Minkowski invariant of a matrix  $A$ ,  $C_p(A)$ . Shrikhande [8] and Chowla and Ryser [2] were the first to use these as the main tools in nonexistence theory. Only the definitions will be provided, properties and proofs can be obtained from Uspenskey and Heaslet [9], Jones [4] and Pall [7].

Let  $p$  be a prime. If  $p$  does not divide  $b$ , and  $X^2 \equiv b \pmod{p}$  has a solution  $X \pmod{p}$ , then  $b$  is a quadratic residue (QR) mod  $p$ , otherwise

it is a quadratic nonresidue (QNR) mod  $p$ .

The property of QR and QNR may be expressed in terms of the Legendre symbol  $(b/p)$  by the rules

$$(b/p) = \begin{cases} +1 & \text{if } b \text{ is a QR} \\ -1 & \text{if } b \text{ is a QNR.} \end{cases}$$

A generalization of the Legendre symbol is the Hilbert norm residue symbol  $(a,b)_p$  which is  $+1$  or  $-1$  according as the congruence

$$ax^2 + by^2 \equiv 1 \pmod{p^m}$$

has or has not, for each value  $m$ , rational solutions  $x$  and  $y$ .  $p$  is any prime and  $a$  and  $b$  are rational numbers.

Two symmetric and nonsingular matrices  $A$  and  $B$  of the same order  $n$ , with rational elements, are rationally congruent if there exists a nonsingular and rational matrix  $C$  of the same order such that  $C'AC = B$ , where  $C'$  denotes the transposed matrix of  $C$ . This relationship is denoted by  $A \sim B$ . The symbol  $\sim$  will also be used to denote that the square free parts of two integers are the same.

Let  $D_1, D_2, \dots, D_n = |A|$  denote the leading principal minor determinants. Define  $D_0 = 1$ . Then for  $D_i \neq 0$  the Hasse-Minkowski invariant of a matrix  $A$  is given by

$$C_p(A) = (-1, -1)_p \prod_{j=0}^{n-1} (D_{j+1}, -D_j)_p \quad (4)$$

for every prime  $p$  and is invariant for all matrices rationally congruent to  $A$ .

A fundamental theorem on rational congruence due to H. Hasse [3] and one to which we shall appeal is

Theorem 1. Two symmetric and rational matrices,  $A$  and  $B$ , of the same order are rationally congruent if and only if  $|A| \sim |B|$ ,  $\text{index } A = \text{index } B$ , and  $C_p(A) = C_p(B)$  for all primes  $p$ .

2. A NECESSARY CONDITION FOR THE EXISTENCE OF A SBIBD. From equation (4) we find that

$$NN' = \begin{bmatrix} r & \lambda & \cdot & \cdot & \cdot & \lambda \\ \lambda & r & \cdot & \cdot & \cdot & \lambda \\ \cdot & \cdot & \cdot & \cdot & \cdot & \cdot \\ \cdot & \cdot & \cdot & \cdot & \cdot & \cdot \\ \cdot & \cdot & \cdot & \cdot & \cdot & \cdot \\ \lambda & \lambda & \cdot & \cdot & \cdot & r \end{bmatrix} = (r-\lambda)I_v + \lambda J_{vv}$$

and that  $\det (NN') = (r-\lambda)^{v-1} [r+\lambda(v-1)] = rk(r-\lambda)^{v-1} > 0$ .

It may be shown that  $NN' \sim I_v$ . Also, since the rank of  $N$  is  $v$ ,  $\text{index } NN' = \text{index } I_v = v$ . For a matrix of the form  $A = eI_m + fJ_m$ , then (Ogawa[6])

$$C_p(A) = (-1-1)_p (-1,e)_p^{m(m-1)/2} (-1,g)_p (m,g)_p (m,e)_p (g,e)_p^{m-1}$$

where  $g = e+mf$ . Using this result we find

$$C_p(I_v) = (-1,-1)_p$$

and

$$C_p(NN') = (-1,-1)_p (-1,r-\lambda)_p^{v(v-1)/2} (v,r-\lambda)_p.$$

Hence, we obtain

Theorem 2. The necessary conditions for the existence of a SBIBD with parameters  $v,r,\lambda$  are that

$$(r-\lambda)^{v-1} \sim 1$$

and if so, then

$$(-1,r-\lambda)_p^{v(v-1)/2} (v,r-\lambda)_p = +1 \quad (5)$$

for all primes  $p$ .

The design with parameters  $v=b=29$ ,  $r=k=8$ ,  $\lambda=2$  satisfies equations (1) and (2). Using the theorem  $(8-2)^{28} \sim 1$ , but using (5)

$$(-1,6)_p^{29 \cdot 28/2} (29,6)_p = (29,6)_p = (29,3)_p (29,2)_p.$$

But for  $p=3$ ,  $(29,3)_3 (29,2)_3 = -1$  which implies that the design does not

exist.

3. INTRA- AND INTER-GROUP BALANCED INCOMPLETE BLOCK DESIGNS. Nair and Rao [5] defined incomplete block designs for experiments involving several groups of treatments which are known as intra- and inter-group BIBDs(I-IBIBD). In such designs one is interested in achieving equal accuracy for comparisons between all pairs of treatments belonging to the same group.

An I-IBIBD is defined as follows:

- (a) The experimental material is divided into  $b$  blocks of  $k$  units each, different treatments being applied to the units in the same block.
- (b) There are  $m$  groups of treatments consisting of  $v_1, v_2, \dots, v_m$  treatments.
- (c) Treatments belonging to the  $i$ -th group are replicated  $r_i$  times,  $i=1, 2, \dots, m$ .
- (d) Every pair of treatments in the  $i$ -th group occur together in  $\lambda_{ii}$  blocks ( $i=1, 2, \dots, m$ ), and every pair of treatments one of which belongs to the  $i$ -th group and the other to the  $j$ -th group occur together in  $\lambda_{ij}$  blocks ( $i \neq j, i, j=1, 2, \dots, m$ ).

The numbers  $v_i, b, k, r_i, \lambda_{ij}$  ( $i, j=1, 2, \dots, m$ ) are known as the parameters of the I-IBIBD  $m$ -group design. The parameters must first satisfy the following relations in order for the design to exist.

$$v = \sum_{i=1}^m v_i \quad \sum_{i=1}^m v_i r_i = bk \quad (6)$$

$$\lambda_{ii}(v_i - 1) + \sum_{\substack{j \neq i \\ j=1}}^m \lambda_{ij} v_j = r_i(k-1), \quad i=1, 2, \dots, m. \quad (7)$$

By arranging the treatments within a group in order and the groups of treatments in order we obtain

$$NN' = \begin{bmatrix} A_1 & B_{12} & \cdots & B_{1m} \\ B_{21} & A_2 & \cdots & B_{2m} \\ \cdot & \cdot & \cdots & \cdot \\ \cdot & \cdot & \cdots & \cdot \\ B_{m1} & B_{m2} & \cdots & A_m \end{bmatrix}$$

where  $A_i = (r_i - \lambda_{ii})I_{v_i} + \lambda_{ii}J_{v_i, v_i}$ ,  $B_{ij} = \lambda_{ij}J_{v_i, v_j}$ ,  $i \neq j$  and  $B_{ji} = B_{ij}$ . If in particular  $r_i = r$ ,  $\lambda_{ii} = \lambda_1$ ,  $\lambda_{ij} = \lambda_2$  then the design reduces to a group divisible design.

Consider the case for  $m=2$ . Then

$$NN' = \begin{bmatrix} A_1 & B_{12} \\ B_{21} & A_2 \end{bmatrix}.$$

Since  $A_2$  is nonsingular, the determinant may be evaluated from

$$\det(NN') = \det(A_2) \det(A_1 - B_{12} A_2^{-1} B_{21}).$$

After some manipulations we find

$$\begin{aligned} \det(NN') &= (r_2 - \lambda_{22})^{v_2 - 1} (r_1 - \lambda_{11})^{v_1 - 1} ((r_2 + \lambda_{22}(v_2 - 1)) \\ &\quad \cdot (r_1 + \lambda_{11}(v_1 - 1))) - v_1 v_2 \lambda_{12}^2 \end{aligned}$$

Let  $p_i = r_i + \lambda_{ii}(v_i - 1)$ ,  $P_i = (r_i - \lambda_{ii})^{v_i - 1}$ , and  $R_i = p_i / v_i$ ,  $i=1, 2$ . In order to evaluate the Hasse-Minkowski invariant of  $NN'$  for the 2-group design we note that the leading principal minor determinants may be put in the form

$$D_i = (r_1 - \lambda_{11})^{i-1} (r_1 + \lambda_{11}(i-1)), i=1, 2, \dots, v_1$$

$$D_{v_1+j} = (P_1)(v_1 P_{2j} v_2 \det(Z_j)) = P_1 D'_j, j=1, 2, \dots, v_2$$

where  $P_{2j} = (r_2 - \lambda_{22})^{j-1}, v_{2j} = j$  and

$$\det(Z_j) = R_1 R_{2j}^{-\lambda_{12}^2}.$$

Using the definition for the Hasse-Minkowski invariant we obtain

$$\begin{aligned} C_p(NN') &= (-1, -1)_p \prod_{j=0}^{v_1+v_2-1} (D_{j+1}, -D_j)_p \\ &= \left[ (-1, -1)_p (D_1, -D_0)_p (D_2, -D_1)_p \cdots (D_{v_1}, -D_{v_1-1})_p \right] \\ &\quad \cdot (D_{v_1+1}, -D_{v_1})_p \cdots (D_{v_1+v_2}, -D_{v_1+v_2-1})_p \\ &= C_p(A_1) (D_{v_1+1}, -D_{v_1})_p \cdots (D_{v_1+v_2}, -D_{v_1+v_2-1})_p \\ &= (-1, -1)_p C_p(A_1) (P_1, D'_{v_2})_p \left[ (-1, -1)_{p_j=1} \prod_{j=1}^{v_2} (D'_j, -D'_{j-1})_p \right]. \end{aligned}$$

The terms in the brackets are of a form similar to a Hasse-Minkowski invariant for  $D'_{v_2}$ . Noting this we write

$$C_p(NN') = (-1, -1)_p C_p(A_1) C_p^*(D'_{v_2}) (P_1, D'_{v_2})_p.$$

If  $v_1+v_2 = b$  and if  $\det(NN') > 0$ , then  $NN' \sim I_{v_1+v_2}$  and we obtain

**Theorem 3.** Necessary conditions for the existence of a I-IBIBD with  $\overline{v_1+v_2} = b$  and  $\det(NN') > 0$  are that



$$P_1 P_2 (P_1 P_2 - v_1 v_2 \lambda_{12}^2) \sim 1$$

and if so then

$$C_p(A_1) C_p^*(D'_{v_2}) (P_1, D'_{v_2})_p = +1 \quad (8)$$

for all primes  $p$ .

For a design with parameters  $v_i=5, r_i=k=6, \lambda_{11}=\lambda_{22}=5, \lambda_{12}=2, b=10$  the initial parametric equations, (6) and (7), are satisfied,  $\det(NN') \sim 1$ , but for  $p=13$  it may be shown that

$$C_p(A_1) C_p^*(D'_{v_2}) (P_1, D'_{v_2})_p = -1$$

which implies that the design does not exist. It may be noted that this design is also a group divisible design. Utilizing Bose and Connors [1] results for GD designs, the product is also  $-1$ , confirming our result.

#### REFERENCES

- [1] Bose, R. C. and Connor, W. S. (1952). Combinatorial properties of group divisible incomplete block designs. Ann. Math. Statist., 23, 367-383.
- [2] Chowla, S. and Ryser, H. J. (1950). Combinatorial problems. Can. J. Math., 2, 93-99.
- [3] Hasse, H. (1923). Über die Äquivalenz quadratischer Formen im Körper der rationalen Zahlen. J. Reine Angew. Math., 152, 205-224.
- [4] Jones, B. W. (1950). The arithmetic theory of quadratic forms. Carus Math. Monograph No. 10, John Wiley and Sons, New York.
- [5] Nair, K. R. and Rao, C. R. (1942). Incomplete block designs for experiments involving several groups of varieties. Science and Culture, 7, 615-616.
- [6] Ogawa, J. (1959). A necessary condition for the existence of regular and symmetrical experimental designs of triangular type, with partially balanced incomplete blocks. Ann. Math. Statist., 30, 1063-1071.
- [7] Pall, G. (1935). On the order invariants of integral quadratic forms. Quarterly J. Math., 6, 30-51.
- [8] Shrikhande, S. S. (1959). The uniqueness of the  $L_2$  association scheme. Ann. Math. Statist., 30, 781-798.
- [9] Uspensky, J. V. and Heaslet, M. H. (1939). Elementary number theory, McGraw-Hill Publ. Co., New York.

# SOME USES OF ORDER STATISTICS<sup>1</sup>

H. A. David  
Department of Statistics  
Iowa State University, Ames

ABSTRACT. Various uses of order statistics (OS), particularly in reliability studies and robust estimation, are first briefly reviewed. A more detailed treatment is then given of three further uses of OS, namely in data compression, selection procedures, and in some double sampling situations. Concomitants of OS are defined and applied to the last two areas. It is shown that considerable savings may be possible in the estimation of the mean of a random variable  $Y$ , which is expensive to measure, if a correlated random variable  $X$  can be cheaply determined. Tables are provided to allow immediate application of the techniques described.

1. INTRODUCTION. If the random variables  $X_1, X_2, \dots, X_n$  are rearranged in ascending order of magnitude and then written as

$$X_{(1)} \leq X_{(2)} \leq \dots \leq X_{(n)}$$

we call  $X_{(r)}$  the order statistic of rank  $r$  or simply the  $r^{\text{th}}$  order statistic ( $r = 1, 2, \dots, n$ ). In this paper we concentrate on the commonly occurring case when the (unordered)  $X_i$  ( $i = 1, 2, \dots, n$ ) are independent r.v.'s with common cumulative distribution function (c.d.f.)  $P(x)$ . It then follows at once that

$$\Pr \{X_{(n)} \leq x\} = \Pr \{\text{all } X_i \leq x\} = P^n(x) \quad (1)$$

and

$$\Pr \{X_{(1)} > x\} = \Pr \{\text{all } X_i > x\} = [1 - P(x)]^n. \quad (2)$$

These results have interesting interpretations, for if  $X_i$  is the lifetime of the  $i^{\text{th}}$  component in a parallel system of  $n$  like components, then  $X_{(n)}$  is the lifetime of the last component to fail, i.e.,  $X_{(n)}$  is the lifetime of the system. Likewise  $X_{(1)}$  is the lifetime of a series system. Thus, knowing the probability distribution of component lifetime, we can from (1) and (2) deduce the probability distribution of a parallel or series system consisting of  $n$  such components. Indeed, if the components are unlike and  $X_i$  has c.d.f.  $P_i(x)$ , eqs. (1) and (2) are easily modified to

---

<sup>1</sup>Work supported by the Army Research Office - Durham.

$$\Pr \{X_{(n)} \leq x\} = P_1(x) P_2(x) \dots P_n(x), \quad (3)$$

$$\Pr \{X_{(1)} > x\} = [1 - P_1(x)] [1 - P_2(x)] \dots [1 - P_n(x)]. \quad (4)$$

There is an obvious connection with problems of reliability. If  $R_i(x)$  is the probability that the  $i^{\text{th}}$  component is still functioning at time  $x$ , then  $R_i(x) = 1 - P_i(x)$ , and (4) gives the well-known result that the reliability of a series system is the product of the component reliabilities, it being assumed that the components fail independently.

Closely related are problems of life testing; for if  $n$  like items (e.g., light bulbs) are put on test simultaneously the life test will take time  $X_{(n)}$  to completion. We may wish to terminate the test earlier, say as soon as the  $r^{\text{th}}$  item has failed (Type II censoring). The test then lasts time  $X_{(r)}$  and we are led to study the behavior of  $X_{(r)}$ , especially its expected value  $\mu_{r:n}$  and its variance  $\sigma_{r:n}^2$ . As a matter of fact, we will usually be able to observe the order statistics  $X_{(1)}$ ,

$X_{(2)}$ , ...,  $X_{(r)}$ , the lifetimes of all failed items. If we can assume an appropriate distribution of lifetime, such as the normal  $N(\mu, \sigma^2)$ , then it is easy, with the help of tables, to construct linear functions of the order statistics (OS)  $\sum_{i=1}^r a_i X_{(i)}$  and  $\sum_{i=1}^r b_i X_{(i)}$  which are respectively estimators of  $\mu$  and  $\sigma$  having minimum variance in the class of linear unbiased functions of the OS.

These and many other applications of OS are treated in some detail in [10] and [4]. Among other applications we may single out the use of OS in the construction of distribution-free confidence intervals and tolerance intervals, the use of the range ( $= X_{(n)} - X_{(1)}$ ) as an estimator of scatter especially in quality control, probability plotting, tests for outliers, and extreme-value theory. In recent years there has been particular interest in finding robust estimators, i.e., estimators which are not too greatly affected by the presence of spurious observations or by our failure to assume the correct underlying distribution. OS play a prominent rôle in such robust estimators since the more central observations in an ordered sample are less liable to be affected by both spurious observations and failure of assumptions than are the more extreme ones. Thus a very simple robust estimator which is unbiased for the mean of any symmetric population is the midmean

$$MM = \frac{2}{n} \sum_{i=\frac{1}{4}n+1}^{\frac{3}{4}n} X_{(i)} \quad (n \text{ a multiple of } 4)$$

which is generally more efficient (although not quite as robust) than the familiar sample median

$$M = X_{\left(\frac{1}{2}(n+1)\right)} \quad (n \text{ odd})$$

$$= \frac{1}{2} \left( X_{\left(\frac{1}{2}n\right)} + X_{\left(\frac{1}{2}n+1\right)} \right) \quad (n \text{ even}) .$$

Both MM and M are examples of trimmed means;  $\bar{M}$  is an extreme example, at the other extreme being the untrimmed mean  $\bar{X}$ , not a robust estimator. Many other types of robust estimators have been proposed, the more elaborate 'adapting' themselves to certain features of the sample in an attempt to produce an estimator particularly appropriate for that sample (see e.g. [1]).

We turn now to a more detailed treatment of three further uses of OS, namely in data compression, selection procedures, and in some double sampling situations.

2. DATA COMPRESSION. If the observations in a large random sample of  $n$  from a population of interest are arranged in ascending order, then it is possible to estimate the population mean (and other parameters) from a small number  $k$  of OS, and to do so with remarkably little loss of information if the OS are suitably chosen. For  $k = 2$  the optimal estimator of the mean  $\mu$  of a normal population turns out to be, from large-sample theory,

$$\mu^* = \frac{1}{2} (Z(0.2708) + Z(0.7292)) ,$$

where e.g.  $Z(0.2708)$  stands for the order statistic with rank equal to the integral part of  $0.2708n+1$ . Thus if  $n = 100$

$$\mu^* = \frac{1}{2} (X_{(28)} + X_{(73)}) .$$

The efficiency of  $\mu^*$  is 0.81 (for any large  $n$ ), so that its variance in samples of 100 is equal to the variance of the best estimator, the sample mean, in samples of 81. For  $k = 4$  the optimal estimator is

$$\mu^* = .1918 [Z(.1068) + Z(.8932)] + .3082 [Z(.3512) + Z(.6488)] ,$$

with efficiency 0.92. It should also be noted that  $\mu^*$  is much more robust than the sample mean, since it does not involve the more extreme OS. Table 1 gives  $\mu^*$  for  $k = 2(2)12$ .

An interesting application of  $\mu^*$  and related estimators has been made in space flights [6]. A large sample of, say, particle counts taken on a space craft may be replaced by enough OS to allow (a) satisfactory

estimation on the ground of parameters of interest, such as the mean count, and (b) a test of the assumed underlying distributional form, by means of probability plotting.

3. SELECTION PROCEDURES. Suppose we wish to select the top  $k$  scorers in a certain test taken by  $n$  individuals ( $k < n$ ). How much better than average do we expect the selected group to be? More precisely, we are really interested in the 'selection differential'

$$\Delta(k, n) = E [D(k, n)] , \quad (5)$$

where  $D(k, n)$  is the average scaled difference between the selected OS and the mean score  $\mu$ , viz.

$$D(k, n) = \frac{1}{k} \sum_{i=n+1-k}^n \left( \frac{X_{(i)} - \mu}{\sigma} \right) , \quad (6)$$

where  $\sigma$  is the s.d. of the test score  $X$  which for definiteness we take to be normally distributed.  $\Delta(k, n)$  is readily evaluated with the help of the important Table 2 giving the expected value  $\xi(i|n)$  of the  $i^{\text{th}}$  largest order statistic from a standardized normal distribution, viz.

$$\xi(i|n) = E \left( \frac{X_{(n+1-i)} - \mu}{\sigma} \right) . \quad (7)$$

Example 1.  $\Delta(1, 20) = \xi(1|20) = 1.867$

$$\Delta(5, 20) = \frac{1}{5} (1.867 + 1.408 + 1.131 + 0.921 + 0.745) = 1.214 .$$

If  $\mu = 100$ ,  $\sigma = 16$ , typical values for IQ tests, we see that the expected score of the best in 20 is

$$E X_{(20)} = \mu + \sigma \xi(1|20) \quad \text{by (7)}$$

$$= 100 + 16(1.867) = 130$$

and the expected average score of the five best is

$$100 + 16(1.214) = 119.4 .$$

Very extensive tables of the expected values of OS from normal, exponential, Weibull, and gamma distributions are provided in [6]. A useful approximation to  $\Delta$  covering also non-normal distributions, is given in [2].

Sometimes we may also be interested in the variance of  $D(k, n)$ . From (6) it is clear (see [11] for explicit results) that this can be found from tables of variances and covariances of OS:

$$\beta_{rr':n} = \text{cov} \left( \frac{X_{(r)} - \mu}{\sigma}, \frac{X_{(r')} - \mu}{\sigma} \right), \quad (8)$$

( $r = 1, 2, \dots, n$ ;  $r' = 1, 2, \dots, n$ ;  $r = r'$  gives variance). The means, variances, and covariances of OS in samples of  $n \leq 20$  have been tabulated not only for the standard normal distribution ([10], p. 200 or [9], Table 10) but for a variety of other distributions which depend only on a location and a scale parameter (for a listing see [4], p. 226). For larger samples approximations are available.

Often we are interested in how individuals selected because of their good scores on  $X$  may be expected to score on  $Y$ , a r.v. to be measured in a later test. We shall assume that  $Y$  is linearly related to  $X$  except for an independent error term  $Z$ :

$$Y_i = \mu_Y + \beta(X_i - \mu_X) + Z_i, \quad i = 1, 2, \dots, n \quad (9)$$

where  $\mu_X = E(X)$ ,  $\mu_Y = E(Y)$ ,  $\beta = \rho\sigma_Y/\sigma_X$ ,  $\rho$  being the correlation coefficient between  $X$  and  $Y$  which have respective standard deviations  $\sigma_X$  and  $\sigma_Y$ ; without essential loss of generality we take  $\rho \geq 0$ . From (9) it follows that  $\mu_Z = 0$  and  $\sigma_Z^2 = (1-\rho^2)\sigma_Y^2$ . An important special case of (9) occurs when  $X$  and  $Y$  are bivariate normal (when  $Z$  must also be normal).

Now if we order the  $X$ 's, eq. (9) gives

$$Y_{[r]} = \mu_Y + \rho\sigma_Y(X_{(r)} - \mu_X)/\sigma_X + Z_{[r]} \quad r = 1, 2, \dots, n, \quad (10)$$

where  $Y_{[r]}$  and  $Z_{[r]}$  denote the r.v.'s  $Y$  and  $Z$  associated with  $X_{(r)}$ . Because of the mutual independence of all  $n$   $X$ 's and  $n$   $Z$ 's in (9), ordering of the  $X$ 's does not affect the distribution of the  $Z$ 's, so that the  $Z_{[r]}$  are, like the  $Z_i$ ,  $n$  independent r.v.'s with mean 0 and variance  $\sigma_Z^2$ . The  $Y_{[r]}$  are the r.v.'s of interest and we call  $Y_{[r]}$  the concomitant of the  $r^{\text{th}}$  order statistic.

On taking expectations in (10) we have

$$E(Y_{[r]}) = \mu_Y + \rho\sigma_Y E \left( \frac{X_{(r)} - \mu_X}{\sigma_X} \right) \quad (11)$$

or

$$E \left( \frac{Y_{[r]} - \mu_Y}{\sigma_Y} \right) = \rho E \left( \frac{X_{(r)} - \mu_X}{\sigma_X} \right).$$

This result may be described by saying that for the r.v.  $Y_{[r]}$  the selection differential of  $X_{(r)}$  is attenuated by the factor  $\rho$ .

From (10) we have also

$$\text{var } Y_{[r]} = \sigma_Y^2(\rho^2 \beta_{rr:n} + 1 - \rho^2) \quad (12)$$

and for  $s = 1, 2, \dots, n$  ( $s \neq r$ )

$$\text{cov}(Y_{[r]}, Y_{[s]}) = \sigma_Y^2 \rho^2 \beta_{rs:n} \quad (13)$$

4. DOUBLE SAMPLING. We are all too frequently faced with the problem of estimating a population mean,  $\mu_Y$  say, from samples smaller than we would like because of the high cost of observing  $Y$  which may, for example, involve destructive testing. Suppose  $n$  items are available to us and we are prepared to measure  $Y$  on  $k$  of them ( $k < n$ ). Now if it is possible to measure cheaply for each of the  $n$  items a quantity  $X$ , correlated with  $Y$ , then such auxiliary measurements can be used to improve the estimation of  $\mu_Y$ . We shall assume that  $X$  and  $Y$  have a bivariate normal distribution (possibly after suitable transformations) although the method below is applicable to the more general model (9).

Instead of the mean  $\bar{Y}_k$  of  $k$  randomly chosen observations on  $Y$  we propose the following estimator:

$$\bar{Y}_{[k]} = \frac{1}{k} \sum_{j=1}^k Y_{[r_j]},$$

where  $Y_{[r_j]}$  is the concomitant of  $X_{(r_j)}$ , the r.v. of rank  $r_j$  among the  $X$ 's. Table 3 gives the values of  $r_1, r_2, \dots, r_k$  which minimize the variance (obtainable through (12) and (13)) of the unbiased estimator  $\bar{Y}_{[k]}$  for various  $n$  and  $k$ . Our double sampling procedure is therefore as follows:

- (i) Arrange the  $n$  measurements on  $X$  in ascending order of magnitude.
- (ii) Then measure  $Y$  on those  $k$  items having  $X$ -ranks  $r_1, r_2, \dots, r_k$ .
- (iii) Take the average of these  $k$   $Y$ -values to obtain  $\bar{Y}_{[k]}$ .

Note that we actually need to know only the ranks of the  $X$ 's to find  $\bar{Y}_{[k]}$ . If the numerical values of the  $X$ 's are available, then it is also possible to use regression estimates with randomly chosen  $Y$ 's [3] or, better still, with selected concomitants but it turns out [7] that the simple  $\bar{Y}_{[k]}$  is generally quite efficient. Table 4 gives the variance of  $\bar{Y}_{[k]}$  as a function of  $|\rho|$  for  $n = 19$  and  $49$  and  $k = 4$  and  $10$ . For  $\rho = 0$ ,  $\bar{Y}_{[k]}$  is equivalent to  $\bar{Y}_k$ . Entries for  $|\rho| > 0$  therefore indicate the reduction in variance due to the use of the auxiliary variables.

## REFERENCES

- [1] Andrews, D. F., Bickel, P. J., Hampel, F. R., Huber, P. J., Rogers, W. H., and Tukey, J. W. (1972). Robust Estimates of Location. Princeton University Press.
- [2] Burrows, P. M. (1972). Expected selection differentials for directional selection. Biometrics 28, 1091-1100.
- [3] Cochran, W. G. (1963). Sampling Techniques, 2nd Edn. Wiley, New York.
- [4] David, H. A. (1970). Order Statistics. Wiley, New York.
- [5] Eisenberger, I. and Posner, E. C. (1965). Systematic statistics used for data compression in space telemetry. J. Amer. Statist. Assoc. 60, 97-133.
- [6] Harter, H. L. (1970). Order Statistics and Their Uses in Testing and Estimation. Vol. 2. U. S. Government Printing Office, Washington, D.C.
- [7] O'Connell, M. J. and David, H. A. (1975). Order statistics and their concomitants in some double sampling situations. To appear in a volume in honor of J. Ogawa.
- [8] Pearson, E. S. and Hartley, H. O. (1966). Biometrika Tables for Statisticians, Vol. I, 3rd Edn. Cambridge University Press.
- [9] Pearson, E. S. and Hartley, H. O. (1972). Biometrika Tables for Statisticians, Vol. II. Cambridge University Press.
- [10] Sarhan, A. E. and Greenberg, B. G. (Eds.) (1962). Contributions to Order Statistics. Wiley, New York.
- [11] Schaeffer, L. R., Van Vleck, L. D., and Velasco, J. A. (1970). The use of order statistics with selected records. Biometrics 26, 854-859.



Table 1. Expected values of normal order statistics  $\xi(i|n) = \mu_{n+1-i:n}$

$i \backslash n$	2	3	4	5	6	7	8	9	10	11	12
1	0.564	0.848	1.029	1.163	1.267	1.352	1.424	1.485	1.539	1.586	1.629
2		.000	0.297	0.495	0.642	0.757	0.852	0.932	1.001	1.062	0.116
3			.000	.000	.202	.353	.473	.572	0.656	0.729	0.793
4						.000	.153	.275	.376	.462	.537
5								0.000	0.123	0.225	0.312
6										.000	.103

$i \backslash n$	13	14	15	16	17	18	19	20	21	22	23	24	25
1	1.668	1.703	1.736	1.766	1.794	1.820	1.844	1.867	1.89	1.91	1.93	1.95	1.97
2	1.164	1.208	1.248	1.285	1.319	1.350	1.380	1.408	1.43	1.46	1.48	1.50	1.52
3	0.850	0.901	0.948	0.990	1.029	1.066	1.099	1.131	1.16	1.19	1.21	1.24	1.26
4	.603	.662	.715	.763	0.807	0.848	0.886	0.921	0.95	0.98	1.01	1.04	1.07
5	0.388	0.456	0.516	0.570	0.619	0.665	0.707	0.745	0.78	0.82	0.85	0.88	0.91
6	.190	.267	.335	.396	.451	.502	.548	.590	.63	.67	.70	.73	.76
7	.000	.088	.165	.234	.295	.351	.402	.448	.49	.53	.57	.60	.64
8			.000	.077	.146	.208	.264	.315	.36	.41	.45	.48	.52
9					.000	.069	.131	.187	.24	.29	.33	.37	.41
10							0.000	0.062	0.12	0.17	0.22	0.26	0.30
11									.00	.06	.11	.16	.20
12											.00	.05	.10
13													.00

Table 1. Continued

$i \backslash n$	26	28	30	32	34	36	38	40	42	44	46	48	50
1	1.98	2.01	2.04	2.07	2.09	2.12	2.14	2.16	2.18	2.20	2.22	2.23	2.25
2	1.54	1.58	1.62	1.65	1.68	1.70	1.73	1.75	1.78	1.80	1.82	1.84	1.85
3	1.29	1.33	1.36	1.40	1.43	1.46	1.49	1.52	1.54	1.57	1.59	1.61	1.63
4	1.09	1.14	1.18	1.22	1.25	1.28	1.32	1.34	1.37	1.40	1.42	1.44	1.46
5	0.93	0.98	1.03	1.07	1.11	1.14	1.17	1.20	1.23	1.26	1.28	1.31	1.33
6	.79	.85	0.89	0.94	0.98	1.02	1.05	1.08	1.11	1.14	1.17	1.19	1.22
7	.67	.73	.78	.82	.87	0.91	0.94	0.98	1.01	1.04	1.07	1.09	1.12
8	.55	.61	.67	.72	.76	.81	.85	.88	0.91	0.95	0.98	1.00	1.03
9	.44	.51	.57	.62	.67	.71	.75	.79	.83	.86	.89	0.92	0.95
10	0.34	0.41	0.47	0.53	0.58	0.63	0.67	0.71	0.75	0.78	0.81	0.84	0.87
11	.24	.32	.38	.44	.50	.54	.59	.63	.67	.71	.74	.77	.80
12	.14	.22	.29	.36	.41	.47	.51	.56	.60	.64	.67	.70	.74
13	.05	.13	.21	.28	.34	.39	.44	.49	.53	.57	.60	.64	.67
14		.04	.12	.20	.26	.32	.37	.42	.46	.50	.54	.58	.61
15			0.04	0.12	0.18	0.24	0.30	0.35	0.40	0.44	0.48	0.52	0.55
16				.04	.11	.17	.23	.28	.33	.38	.42	.46	.49
17					.04	.10	.16	.22	.27	.32	.36	.40	.44
18						.03	.10	.16	.21	.26	.30	.34	.38
19							.03	.09	.15	.20	.25	.29	.33
20								0.03	0.09	0.14	0.19	0.24	0.28
21									.03	.09	.14	.18	.23
22										.03	.08	.13	.18
23											.03	.08	.13
24												.03	.07
25													0.03

Note: For  $i > \frac{1}{2}n$  use  $\xi(i|n) = -\xi(n+1-i|n)$  (from [8], Table 29).

Table 2. Optimal estimators of the mean of a normal distribution from  $k$  selected order statistics.

$k$		Efficiency
2	$0.5[z(0.2709) + z(0.7291)]$	0.8098
4	$0.1918[z(0.1068) + z(0.8932)] + 0.3082[z(0.3512) + z(0.6488)]$	0.9201
6	$0.0968[z(0.0540) + z(0.9460)] + 0.1787[z(0.1915) + z(0.8085)]$ $+ 0.2245[z(0.3898) + z(0.6102)]$	0.9560
8	$0.0559[z(0.0310) + z(0.9690)] + 0.1119[z(0.1154) + z(0.8846)]$ $+ 0.1550[z(0.2481) + z(0.7519)] + 0.1772[z(0.4126) + z(0.5874)]$	0.9722
10	$0.0366[z(0.0203) + z(0.9797)] + 0.0751[z(0.0768) + z(0.9232)]$ $+ 0.1086[z(0.1684) + z(0.8316)] + 0.1334[z(0.2887) + z(0.7113)]$ $+ 0.1463[z(0.4274) + z(0.5726)]$	0.9808
12	$0.0246[z(0.0135) + z(0.9865)] + 0.0522[z(0.0525) + z(0.9475)]$ $+ 0.0786[z(0.1178) + z(0.8822)] + 0.1012[z(0.2075) + z(0.7925)]$ $+ 0.1174[z(0.3163) + z(0.6837)] + 0.1260[z(0.4373) + z(0.5627)]$	0.9859

(from [5], Table 1 or [9], Table 11a)

Table 3. Optimal ranks  $r_1, r_2, \dots$  of concomitants for the estimator  $\bar{Y}_{[k]}$   
 $n$  = no. of auxiliary variables,  $k$  = no. of concomitants

(a)  $k = 2$

$n$	$r_1$	$n$	$r_1$	$n$	$r_1$	$n$	$r_1$
4	1	17	5	30	9	43	12
5	2	18	5	31	9	44	12
6	2	19	6	32	9	45	13
7	2	20	6	33	9	46	13
8	3	21	6	34	10	47	13
9	3	22	6	35	10	48	13
10	3	23	7	36	10	49	14
11	3	24	7	37	10	50	14
12	4	25	7	38	11	60	17
13	4	26	7	39	11	70	19
14	4	27	8	40	11	80	22
15	4	28	8	41	11	90	25
16	5	29	8	42	12	100	27

(b)  $k = 3(1)10$

$k = 3$		$k = 4$		$k = 5$		$k = 6$			$k = 7$		
$n$	$r_1$	$r_1$	$r_2$	$r_1$	$r_2$	$r_1$	$r_2$	$r_3$	$r_1$	$r_2$	$r_3$
9	2	2	4	1	3						
19	4	3	8	2	6	2	5	8	2	5	7
29	6	4	11	4	9	3	8	13	3	7	11
39	8	6	15	5	12	4	10	17	3	9	14
49	9	7	19	6	15	5	13	21	4	18	25

$k = 8$					$k = 9$				$k = 10$				
$n$	$r_1$	$r_2$	$r_3$	$r_4$	$r_1$	$r_2$	$r_3$	$r_4$	$r_1$	$r_2$	$r_3$	$r_4$	$r_5$
19	2	4	6	9	2	4	6	8	1	3	5	7	9
29	2	6	10	13	2	5	9	12	2	5	8	11	14
39	3	8	13	18	3	7	11	16	3	6	10	14	18
49	4	10	16	22	3	9	14	20	3	8	13	18	23

(from [7])

Table 4. Variance of  $\bar{Y}_{[k]}$  (in units of  $\sigma_Y^2$ ) as a function of  $|\rho|$

$ \rho $	k = 4		k = 10	
	n = 19	n = 49	n = 19	n = 49
0	.2500	.2500	.1000	.1000
0.1	.2481	.2477	.0995	.0992
0.2	.2423	.2409	.0981	.0968
0.3	.2326	.2295	.0958	.0929
0.4	.2190	.2135	.0925	.0873
0.5	.2016	.1930	.0883	.0802
0.6	.1803	.1680	.0832	.0715
0.7	.1551	.1384	.0771	.0612
0.8	.1261	.1042	.0701	.0494
0.9	.0932	.0655	.0622	.0359
0.95	.0753	.0444	.0579	.0286
1	.0564	.0222	.0533	.0209

(from [7])

# OPTIMAL RESOURCE ALLOCATION FOR MAXIMIZING SYSTEM RELIABILITY

Gerald J. Lieberman

Department of Operations Research and Department of Statistics  
Stanford University, Stanford, California

O. ABSTRACT. In the design of a new system, or the maintenance of an old system, allocation of resources is of prime consideration. In allocating resources it is often beneficial to develop a solution that yields an optimal value of the system measure of desirability. In the context of the problems considered in this paper the resources to be allocated are components already produced (assembly problems) and money (allocation in the construction or repair of systems). The measure of desirability for system assembly will usually be maximizing the expected number of systems that perform satisfactorily and the measure in the allocation context will be maximizing the system reliability.

I. INTRODUCTION. This work on the optimal resource allocation for maximizing system reliability represents a summary of research in this area conducted by Cyrus Derman, Sheldon Ross and Gerald J. Lieberman. The basic problem is to allocate resources in a way that yields an optimal value of the system measure of desirability. Specifically the problems considered can be categorized as shown in the following table.

Resources to be Allocated	Type Problem	Measure of Desirability
Money	Allocation of funds in the construction or repair of systems	Maximizing the system reliability
Components already produced	Assembly of systems	Maximizing the expected number of systems that perform satisfactorily

## II. ASSEMBLY PROBLEMS.

II.1. General Formulation. Resources consist of a stockpile of components, and these components are to be arranged in some fashion into a set of working systems. This problem was treated by Derman, Lieberman, and Ross in two papers, "On Optimal Assemble of Systems", NLRQ, Vol. 15, No. 4, December 1972, and "Assembly of Systems Having Maximum Reliability", NLRQ, Vol. 21, No. 1, March 1974. In particular, assume that a single system has  $m$  different types of components. Associated with each component is a numerical value. Let  $\{b^i\}$ ,  $i = 1, 2, \dots, m$ , denote this set of numerical values in the  $m$  components. Let  $R(b^1, b^2, \dots, b^m)$  denote the probability that the system will perform satisfactorily, i.e.,

$R(b^1, b^2, \dots, b^m)$  is the reliability of the system. For example, let  $b^i$  denote the probability that the  $i^{\text{th}}$  component will work when component performances are independent. If all components must work then the reliability is just  $R = b^1 \cdot b^2 \cdots b^m$ . Nevertheless, this formulation allows for the component performances to be dependent. Now suppose that there are  $n$  units of each component with corresponding  $b_1^i, b_2^i, \dots, b_n^i$  for every  $i$ . The problem considered is to arrange the  $nm$  units into  $n$  systems, to maximize the expected number of systems that perform satisfactorily, i.e., maximize  $E(N)$ , where  $N$  is the number of systems that work. Of course this criterion is equivalent to maximizing the sum of the  $n$  reliabilities.

II.2. "Series" Results. If  $R$  is a distribution function (includes a series system of independent components) and if  $b_1^i \leq b_2^i \leq \dots \leq b_n^i$  for  $i = 1, 2, \dots, m$ , then the  $n$  systems represented by the partitions  $(b_1^1, b_1^2, \dots, b_1^m), \dots, (b_n^1, b_n^2, \dots, b_n^m)$  is the optimal arrangement, i.e., put the "worst" together, the second "worst" together, ... , and finally, the "best" together. Furthermore, if  $R(b^1, \dots, b^m) \geq 1/2$  for every permutation of the units, then this same arrangement also minimizes the variance of the number of systems that perform satisfactorily. Finally, if

$$R(b^1, b^2, \dots, b^m) = b^1 b^2 \cdots b^m,$$

where

$$b^i = P\{i^{\text{th}} \text{ component works}\},$$

then this same arrangement maximizes

$$P\{N \geq r\},$$

for each  $r$ .

### II.3. Parallel Systems Having Independent Components - Formulation.

Problem is to arrange the  $nm$  units into  $n$  systems to maximize the expected number of systems that work,  $E(N)$ . In this case,

$$R(b^1, b^2, \dots, b^m) = 1 - \prod_{i=1}^m (1-b^i) = 1 - \prod_{i=1}^m a^i,$$

where

$$a^i = P\{i^{\text{th}} \text{ component fails}\},$$

so that

$$E(N) = \sum_{j=1}^n \left(1 - \prod_{i=1}^m a_j^i\right) = n - \sum_{j=1}^n \prod_{i=1}^m a_j^i.$$

This formulation requires that each (parallel) system contain exactly  $m$  components, and such a requirement may degrade the performance measure in that  $E(N)$  may be larger if we allow for the possibility that some systems contain less than  $m$  units while others contain more. This more general parallel problem is treated as follows:

### II.4. Parallel Systems Having Independent Components - More

General Formulation. A set of  $t$  units is to be partitioned into  $n$  disjoint parallel systems. After completion of a partition the number of units contained in the  $j^{\text{th}}$  system ( $j = 1, 2, \dots, n$ ) is denoted by  $m_j$ , with the added restriction that  $\sum_{j=1}^n m_j = t$ . For a given partition, the reliability of system  $j$ ,  $R_j$ , is given by

$$R_j = 1 - \prod_{\substack{\text{all } i \\ \text{units in} \\ \text{system } j}} a_j^i,$$

so that

$$E(N) = \sum_{j=1}^n R_j = n - \sum_{j=1}^n \prod_{\substack{\text{all } i \\ \text{units in} \\ \text{system } j}} a_j^i.$$



II.5. Results for Parallel Systems. The solution to this problem, i.e., the arrangement that maximizes  $E(N)$ , attempts to make the reliabilities of each system as equal as possible. Indeed, if a partition exists that makes the reliabilities equal, it is optimal. Unfortunately, such an arrangement may not exist. However, bounds are available so that the maximum expected number of systems that perform satisfactorily will be within these bounds; the bounds being a function of an arbitrary chosen partition. Finally, an improvement algorithm is also available. Essentially, this algorithm looks for pairwise interchanges of units which make two systems have "more equal" reliabilities. Incidentally, all the results obtained for this problem carry over to the original problem where each system is required to contain exactly  $m$  components.

II.6. Another Application of Assembly of Systems Model. A version of the target assignment problem can be related to the general parallel system assembly formulation. Manne's "A Target Assignment Model", Operations Research, Vol. 6, No. 3, 1958, treats essentially the following target assignment problem. There are  $t$  weapons to be assigned against  $n$  targets. Let  $p_{ij}$  be the probability that the  $i^{\text{th}}$  weapon will destroy the  $j^{\text{th}}$  target if it alone is assigned to it. The objective is to minimize the expected number of surviving targets. If  $x_{ij}$  denotes the probability that the  $i^{\text{th}}$  weapon is assigned to the  $j^{\text{th}}$  target, then the  $x_{ij}$  are sought that minimize

$$\sum_{j=1}^n \prod_{i=1}^t (1 - p_{ij} x_{ij}) ,$$

subject to

$$\sum_{j=1}^n x_{ij} = 1 , \quad i = 1, 2, \dots, t ,$$

and

$$x_{ij} \geq 0 .$$

II.7. Results for Target Assignment Problem. Manne points out that this is a nonlinear problem and an exact solution is not known. However, by making some simplifying assumptions he presents two approximate solutions (one due to himself and one due to G.B. Dantzig). The analogous concepts in the assembly model version would assume that  $x_{ij}$  is zero or one. The  $i^{\text{th}}$  weapon corresponds to the  $i^{\text{th}}$  unit. The  $j^{\text{th}}$  target corresponds to the  $j^{\text{th}}$  system. Whereas  $p_{ij}$  depends on both the weapon and target, the probability of a unit working in the assembly context is assumed to be independent of which system it is placed in and hence is denoted by  $p_i$ . This would imply that the  $i^{\text{th}}$  weapon has the same probability of destroying each target. Under this assumption (which is less stringent than those proposed by Manne) the system assembly results are relevant.

II.8. Other Work on System Assembly. An independent and earlier discussion of the assembly problem with other application can be found in Abe, "Multi-Stage Rearrangement Problem and its Application to Multiple System Reliability", Journal of the Operations Research Society of Japan, Vol. 11, No. 1, November 1968. He uses somewhat different techniques, particularly in the parallel case. In the reliability context he always assumes independence of components, and his version of the parallel system problem requires each system to contain  $m$  units. However, for this case he obtains some sufficient conditions for optimality weaker than equal reliabilities. He also points out that the assembly model can be used in search and assignment contexts.

### III. ALLOCATION PROBLEMS.

III.1. General Allocation Problem. Let  $A$  denote a fixed amount of money to be used to build a single system consisting of  $n$  components. Define  $P_i(x_i)$  as the probability that component  $i$  will work if  $x_i$  is allocated to its production. The problem is to choose  $x_1, x_2, \dots, x_n$  so as to maximize the probability that the system works, i.e.,

maximize

$$R[P_1(x_1), P_2(x_2), \dots, P_n(x_n)]$$

subject to

$$\sum x_i = A ,$$

where  $R$  is the probability that the system performs satisfactorily.

### III.2. Special Cases of General Model.

A. System can be represented by  $n$  independent modular subsystems connect in parallel and/or series; in such cases  $R$  has an indentifiable simple form. Bodin, in his paper, "Optimization Procedures for the Analysis of Coherent Structures", IBM Data Processing Division Report No. 320-3509, July 1968, has done some work on this problem. He developed some algorithms, but essentially, the solution is still unknown.

B. In order to get some insight into this general problem, a simple version is considered by Derman, Ross, and Lieberman in a series of papers, (i) "Assembly of Systems Having Maximum Reliability", Naval Research Logistics Quarterly, Vol. 21, No. 1, March 1974, (ii) "Optimal Allocations in the Construction of  $k$  out of  $n$  Reliability Systems", Management Science, Vol. 21, No. 3, November 1974, and (iii) "A Stochastic Sequential Allocation Model", Technical Report No. 165, Stanford University, September 16, 1974. These papers assume that  $P_i(x) = P(x)$  for all components, and the system has a special structure, i.e., it is a  $k$  out of  $n$  system. However, another facet is added, namely, in some of our models allocation decisions can be made sequentially.

III.3. An Allocation of Money Resources Model. Suppose  $A$  denotes a fixed amount of money to build a single system consisting of  $n$  components. Define  $P(x)$  as the probability that a component will work if amount  $x$  is allocated to its production.

A. Non-Sequential Version: Choose  $x_1, x_2, \dots, x_n$  in order to maximize  $R(P(x_1), \dots, P(x_n))$ , i.e., the probability that the system works.

B. Sequential Version:  $x_1$  is allocated to produce the first component. Using the information as to whether the first allocation produced a working or non working component,  $x_2$  is then allocated to produce a 2nd component. We proceed in this manner, making no more than  $n$  allocations. The problem is to choose  $x_1, x_2, \dots, x_n$ , if necessary, sequentially to maximize the probability that the system will work.

It is assumed that an  $n$  component system will work if at least  $k$  of the components function.

#### III.4. Results for an Allocation of Money Resources Model.

(i)  $k = 1$  (parallel system) - sequential or non-sequential version.  
If  $\log(1 - P(x))$  is convex, then the  $x$ 's are chose so that

$$x_1 = x_2 = \dots = x_n = \frac{A}{n} .$$

If  $\log(1 - P(x))$  is concave, then the  $x$ 's are chosen so that

$$x_1 = A, x_2 = 0, \dots, x_n = 0 .$$

(ii) General  $k$  (note  $k = n$  is series-system) - sequential or non-sequential version.

If  $\log(1 - P(x))$  is (strictly) convex then if one wants to sequentially build  $k$  working components in at most  $n$  attempts,  $n \geq k$ , then it is (uniquely) optimal to allocate  $A/n$  at each stage when  $A$  is the total resource available. Thus, it also follows that the same allocation is optimal for the non-sequential model.

(iii) Special case of  $P(x) = x$  - sequential case -  $k = 1$  and  $2$ . Since  $\log(1-x)$  is a concave function, the results presented under (i) hold for  $k = 1$ , i.e.,  $x_1 = A$ ,  $x_2 = 0, \dots, x_n = 0$ . Exact results can also be obtained for the case of  $k = 2$ . The optimal policy  $\pi^*$  can be described as follows. When the present amount available is  $y$  and at most  $n$  additional components can be built, then

- a) if only one additional working component is needed,  $\pi^*$  allocates  $\min(y, 1)$ , and
- b) if two additional working components are needed,  $\pi^*$  allocates

$$\begin{cases} y - 1 & \text{if } y \geq \frac{n}{n-1} \\ \frac{y}{n} & \text{if } y \leq \frac{n}{n-1} \end{cases}$$

(iv) Special case of  $P(x) = x$  - sequential case - general  $k$ . For the general case (any  $k$ ), it is conjectured that the optimal policy  $\pi^{**}$  is such that when the present amount available is  $y$  and if  $k$  additional working components are needed with at most  $n$  stages to go, then  $\pi^{**}$  calls for allocating

$$\begin{cases} \frac{y}{n} & \text{if } y \leq \frac{n}{n-1} (k-1) \\ y - (k-1) & \text{if } y \geq \frac{n}{n-1} (k-1) \end{cases}$$

(v) Special case of  $P(x) = x$  - non-sequential case. The optimal allocation  $\underline{x}^* = (x_1^*, x_2^*, \dots, x_n^*)$  is such that all of the non-zero elements of  $\underline{x}^*$  are equal. It is not clear how many non-zero elements are presented in an optimal allocation, although some indications are available for  $A$  near  $k$  or zero; for  $A$  near  $k$  the number of non-zero elements is small while for  $A$  near zero the number is large.

III.5. A Stochastic Sequential Allocation Model (SSAM). The following model is described in terms of an investment problem, although several other interpretations are available for this model. We have  $D$  units available for investment. During each of  $N$  time periods an opportunity to invest will occur with probability  $p$ . As soon as an opportunity presents itself we must decide how much of our available resources to invest. If we invest  $x$ , then we obtain an expected profit  $P(x)$ , where  $P$  is a nondecreasing continuous function. The amount  $x$  then becomes unavailable for future investment. The problem is to decide how much to invest at each opportunity so as to maximize the total expected profit.

III.6. Other Applications of SSAM.

A. Target Assignment Application of SSAM. Suppose that there are  $D$  units of ammunition available, and for each of  $N$  time units, say days, the target may be under attack. During each of the  $N$  days enemy planes will attack with probability  $p$ . As soon as planes appear, we must decide how much of our ammunition to expend. If  $x$  units of ammunition are expended then  $P(x)$  is the expected number of enemy planes that will be downed.

B. Allocation of Research Effort Application of SSAM. A proposal is received and sent out for review. From past history the fraction of those receiving favorable reviews are  $p$  ( $p$  may be thought of as the probability of the referee recommending funding). However, the review comes in as recommending approval or rejection. If the review is positive, how much should be allocated to each proposal. We have a total of  $D$  dollars available. If  $x$  is allocated, then  $P(x)$  is the return of the investment. We have  $N$  proposals to be sent for review and decisions must be made sequentially. Another interpretation is for  $p$  to represent the probability of a favorable report being received in each of  $N$  given days.

III.7. Results for SSAM Model. When  $P(x)$  is convex, it is easily shown that the optimal policy is to invest everything when an opportunity presents itself. When  $P(x) = \log x$ , and if there are  $n$  time periods to go and  $A$  dollars available then the optimal amount to invest at this time,  $x_n(A)$ , is given by

$$x_n(A) = \frac{A}{1 + (n-1)p}.$$

Another case where the optimal policy can be made explicit is when

$$P(x) = x^\alpha, \quad 0 < \alpha < 1.$$

III.8. Further Results for SSAM Model. When  $P(x)$  is a general concave function, it is only possible to describe the structure of the optimal policy. In particular, if  $V(n,A)$  denotes the supremal expected additional profit attainable when there are  $n$  time periods to go,  $A$  dollars available, and an investment opportunity is at hand, and  $x_n(A)$  is the optimal amount to invest at this time, then

- (i)  $V(n,A)$  is a concave function of  $A$ ,
- (ii)  $x_n(A)$  is a nondecreasing function of  $A$ , and
- (iii)  $x_n(A)$  is a nonincreasing function of  $n$ .

This structure can be used to simplify the necessary computations, but does not yield a closed form expression for the optimal value to invest.

III.9. The Sequential Stochastic Assignment Problem. It is assumed that there are  $n$  men available to perform  $n$  jobs. The jobs arrive in sequential order with each job being categorized before a man is assigned to it. It is assumed that the category  $e_j$  of the  $j^{\text{th}}$  job is determined by a probability measure over all possible categories and that  $\{e_j\}$  ( $j = 1, \dots, n$ ) are independent with the same probability measure. The  $i^{\text{th}}$  man has a value  $x_i$  ( $0 \leq x_i \leq 1$ ,  $i = 1, \dots, n$ ) associated with him. If the  $i^{\text{th}}$  man is assigned to

the  $j^{\text{th}}$  job the (expected) return is a known function  $P(x_i, \theta_j)$ . After a man is assigned to a job, he is unavailable for future assignments. The objective is to assign the workers sequentially to maximize total expected return. This problem was treated by Derman, Lieberman, and Ross in "A Sequential Stochastic Assignment Problem", Management Science, Vol. 18, No. 7, March 1972.

III.10. Relationship of SSAM to the Sequential Stochastic Assignment Problem. In the stochastic sequential allocation model the possible categories are two in number. The first category, which occurs with probability  $1-p$ , corresponds to  $P(x, \theta_1) \equiv 0$  (no occurrence of an opportunity); the second, which occurs with probability  $p$ , to  $P(x, \theta_2) = P(x)$  (occurrence of an opportunity). The  $n$  men each having a value  $x_i$  ( $i = 1, \dots, n$ ) is equivalent to a predetermined division of the total resources  $\sum_{i=1}^n x_i = D$  and the problem is simply that of assigning the predetermined values. The allocation problem requires instead of a sequential assignment of values a sequential division of the resources. Beyond occurring or not occurring the present allocation model does not permit a more refined weighing of the return function since  $P(x)$  is assumed to be the same for each occurrence.

IV. CONCLUSIONS. Are results relevant for solving the general allocation problem? Can they be used to aid in the design of a new system or in the maintenance of an old system. Obtaining an explicit solution to the general allocation problem requires intimate knowledge of cost functions and system performance. Similarly, this information also appears to be necessary for obtaining explicit solutions to the "simplified" models considered in this paper -- with one important difference -- namely, most solutions lead to qualitative results. Admittedly, the "optimal solution" to the general allocation problem is still open, but the results presented in this paper are useful in enhancing "engineering intuition" for the purpose of getting "good" answers to a most difficult problem.



Finally, the models presented, usually in a reliability context, are quite broad so that they are useful in other areas, e.g., the assembly of parallel systems and the stochastic sequential allocation model are related to target assignment problems.

SIMPLE STATISTICAL ALTERNATIVES TO THE METHOD OF LEAST SQUARES FOR THE  
DETERMINATION OF X-INTERCEPT AND SLOPE

Joseph F. Hannigan and Mary L. Powers  
Research Institute  
U. S. Army Engineer Topographic Laboratories  
Fort Belvoir, Virginia

ABSTRACT. It is standard procedure to use the method of least squares to obtain the best straight line fit to a given set of data samples which are known or believed to represent some physical quantity having a linear characteristic. There are two reasons for seeking simple alternatives to the method of least squares. The first is that some field applications require only a determination of the X-intercept. The method of least squares determines the slope and Y-intercept from which the X-intercept is then calculated. The second reason is that in some field applications only limited amounts of data can be retained, stored, or manipulated because of restrictions on the ADP systems. This paper examines several alternatives for reducing the amount of data used and a method of determining the X-intercept. Of course, the slope appears in the calculation. However, it is not determined explicitly and the Y-intercept is not determined at all. For this investigation, a set of 100 data samples are used. These data samples were obtained from a random number generator then normalized and applied to the "Y" coordinate appropriate to 100 "x" coordinates for the line  $y = -x + 50$ . Results are evaluated in terms of closeness to the original X-intercept (i.e.,  $x = 50$ ).

1. INTRODUCTION. The purpose of this paper is to present the results of an investigation which explored a statistical alternative and a statistical variation on the method of least squares. In addition, the effect of simply reducing the number of data samples was examined. These latter results are presented in Appendix A simply to show the effect of loss of data. The loss could be deliberate to reduce the amount of data for simplicity or it could be accidental due to equipment malfunction.

The method of least squares has many applications from massive batch reductions, such as simultaneous adjustments of large geodetic networks, to the relatively simple, straight forward determination of the "best" straight line fit for data which are known or believed to represent a physical quantity having a linear characteristic. "Best" fit in the latter case means the equation for the straight line which comes closer to all the data points than any other straight line. In other words, it usually means the line for which the deviations between the given ordinate values of the data points and the corresponding ordinates of the line are a minimum. This is the specific application being considered in this investigation.

There are two reasons for seeking alternatives to the method of least squares. The first is that some field applications require only a determination of the X-intercept. The method of least squares determines the slope and Y-intercept from which the X-intercept is calculated. The second reason is that in some field applications only limited amounts of data can be stored, retained, and manipulated because of restrictions on the size and capacity of the ADP systems being used.

A specific application to illustrate the above is the potential use of an FM discriminator to determine a particular frequency. The discriminator (here used in the generic sense) could then be used in the field as a cheap replacement or a backup for the more expensive frequency counter. A discriminator has a well known linear frequency versus voltage characteristic. This is apparent in data and figures presented in Appendix B. A disadvantage of the discriminator is that it does not have the resolution of the more expensive frequency counter. However, a discriminator can be sampled every few milliseconds compared to the usual second or more for a frequency counter. The sampling rate for a discriminator is limited only by the settling time of the sampling and data storage circuits while a frequency counter must count for a specific time interval in order to obtain the desired resolution. Compared to a frequency counter a discriminator can provide a very large number of data samples. The method of least squares is recognized as a good, standard procedure to use to determine the best straight line to fit for such data. A specific frequency or frequencies can then be determined from the equation of the line so obtained.

An experiment was conducted at the Research Institute, U. S. Army Engineer Topographic Laboratories, Fort Belvoir, VA, to determine the feasibility of using discriminators for the purpose of determining a specific frequency (e.g., 300.000 kilocycles). Details of the experiment are planned for inclusion in a separate USAETL report. As background information for this paper, Appendix B contains a block diagram of the experiment, tables of representative data, and plots of the data.

2. INVESTIGATION. The approach taken in this investigation was analytical and empirical rather than theoretical. The investigation used both experimental data (shown in Appendix B) and hypothetical data.

The hypothetical data was based on the line  $Y = mX + b$  where the slope  $m$  was chosen to be  $-1$  and the X-intercept was chosen to be  $+50$ . A hundred data samples (X, Y values) were obtained using equally spaced abscissa values from 0 to 99 and calculating the corresponding ordinate values. These ordinate values were then changed by the application of "normalized" random numbers. The distribution is shown in Figure 1. These numbers were obtained from a random number generator and then "normalized." The "normalized" random numbers are shown in Table 1. One hundred data samples are not enough to show a good normal distribution, hence the quotes on normalized.

However, this is the number of samples which would be expected in a specific application and it is more than actually desired from the data storage and manipulation standpoint. In a real case, even though the physical quantity would be expected to have a normal distribution under long term conditions, such distribution might not actually appear in a limited number of samples. Hence, it is believed that the values used are reasonable for what would be obtained in a real situation.

It seems appropriate at this point to illustrate briefly what is involved in determining the X-intercept by the method of least squares.

DATA REQUIRED

<u>X</u>	<u>Y</u>	<u>XY</u>	<u>X<sup>2</sup></u>
.	.	.	.
.	.	.	.
.	.	.	.
.	.	.	.
<u>ΣX</u>	<u>ΣY</u>	<u>ΣXY</u>	<u>ΣX<sup>2</sup></u>

NORMAL EQUATIONS

$$\Sigma Y = m \Sigma X + bN$$

$$\Sigma XY = m \Sigma X^2 + b \Sigma X$$

Where m is the slope, b is the Y-intercept, and N is the number of data samples. The slope and Y-intercept are obtained by the simultaneous solution of the NORMAL EQUATIONS. The X-intercept is then determined by equation:

$$X = - \frac{b}{m}$$

It is significant to note that as the data samples (X, Y) are put into the ADP system, they are summed; they are multiplied and then summed; and the X values are squared and then summed. These operations require either a certain amount of memory to store data while the arithmetical operations are performed or a parallel ADP capability to perform the multiplication, squaring and summing operations simultaneously as the data samples are put into the ADP system.

The next thing to note is that the NORMAL EQUATIONS must be solved simultaneously for the slope (m) and the Y-intercept (b). From these values the X-intercept is then calculated from a third equation. Physically, the Y-intercept has no significance in our experiment, however, the slope gives the rate of change of the frequency. The slope could be used to extrapolate the data in the event

of a malfunction which prevents getting enough data samples to include the desired frequency. Although it is not expected to give a high degree of accuracy, extrapolation might be better than no answer at all. Although the slope is of secondary interest, it is included in the findings since it does have some physical significance.

3. FINDINGS AND RESULTS. The investigation was performed with the hypothetical data first and then the experimental data. The impressive finding was the extremely good results obtained by simple statistical averaging of consecutive data samples to form new sets of data. This gave a reduced number of new data samples which reduces the amount of storage required. It even eliminates the method of least squares when carried to the extreme. For example, by dividing the data into halves, then averaging each half to obtain two average X coordinates and two average Y coordinates, the X-intercept can be obtained directly from the linear equation:

$$X = \frac{(X_2 - X_1)}{(Y_2 - Y_1)} (-Y_1) + (X_1)$$

The above equation is derived from the equation of a straight line between two points. Note that the X-intercept is obtained immediately and that the slope, although present, is not derived explicitly.

The results obtained by reducing the data by simple statistical averaging of consecutive data samples are shown in Table 2 for the hypothetical data and Tables 3 and 4 for the experimental test data. The X-intercept and slope obtained by the method of least squares using all the data samples are shown in Table 5 for comparison purposes.

4. CONCLUSION. Based on the empirical and analytical approach taken in this investigation, it is concluded that simple statistical averaging of the data samples so as to obtain two average data samples (i.e., one average sample for each half of the data) and the application of the single equation for the straight line between two points provides an alternative to the method of least squares for the determination of the X-intercept and slope. The accuracy obtainable with this procedure is believed to be acceptable for many applications, especially in view of the simplicity of the calculations.

It is also concluded that statistical averaging of consecutive data samples provides a variation to the method of least squares which has an accuracy that would be acceptable in many applications. The averaging of consecutive data samples could be used to reduce the data storage requirements or possibly permit parallel arithmetical operations.

It is recognized that these conclusions are based on limited amounts of data. However, intuition tends to support the logic of these conclusions and the numerical results tend to verify them.

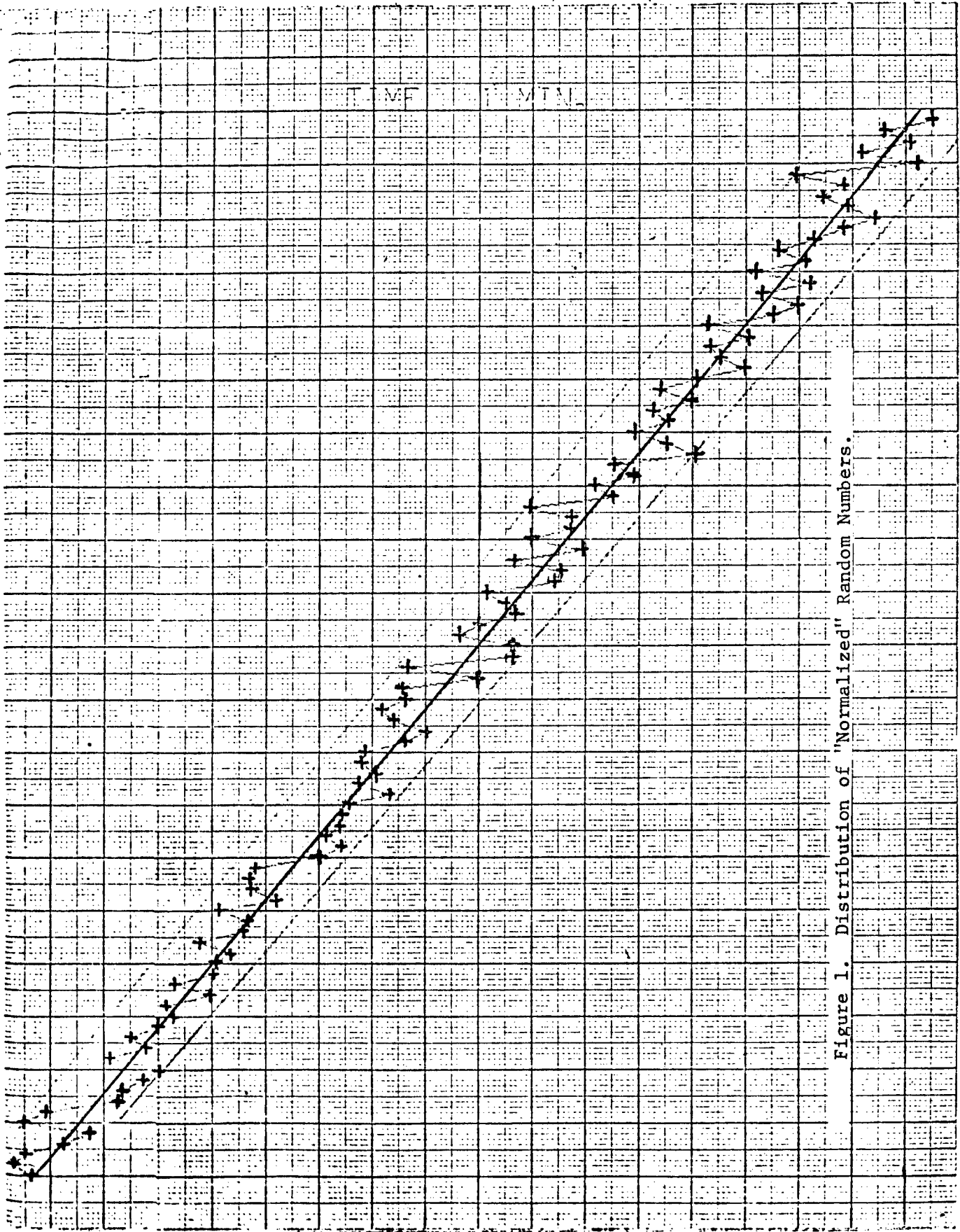


Figure 1. Distribution of "Normalized" Random Numbers.

TABLE 1

HYPOTHETICAL Y VALUES

LEAST SQUARES SOLUTION

X - INTERCEPT                      SLOPE

49.99981

-1.00039

49.96242	29.70875	10.84404	-8.76126	-28.65983
49.99029	28.51381	8.63787	-10.91312	-31.86805
48.88100	29.00789	7.13448	-11.64198	-33.49903
46.70268	26.73117	7.70763	-10.69331	-32.71309
45.08127	25.83577	7.48568	-14.52664	-35.25615
46.91440	26.24694	5.99159	-14.52543	-33.83377
45.37269	23.48569	5.39825	-16.60918	-36.42487
42.01023	23.74931	1.80193	-16.62959	-36.05049
41.17653	23.17326	3.87421	-20.24340	-38.00546
39.77494	22.26243	-.75410	-19.82353	-39.79937
38.33930	19.22088	-1.51869	-19.30977	-41.72312
39.65631	17.67384	-.05276	-21.29225	-41.29069
37.59978	17.61664	-1.49097	-21.34542	-40.99205
37.52239	16.42751	-3.50078	-23.46376	-42.51869
35.83357	15.61575	-3.81862	-22.92517	-41.31404
34.59748	15.12530	-3.78212	-24.97300	-46.55431
34.22336	12.50790	-6.99264	-27.46301	-45.18235
31.88084	13.02590	-7.91377	-27.20892	-47.64346
32.57741	11.72757	-6.76613	-27.51879	-47.37441
30.47543	11.55778	-10.02956	-29.60704	-49.87412

TABLE 2. HYPOTHETICAL DATA

<u>LEAST SQUARES SOLUTION USING</u>				<u>STRAIGHT LINE BETWEEN TWO END POINTS SOLUTION USING</u>	
<u>Averages of Each of 10 Consecutive Samples</u>		<u>Averages of Each of 20 Consecutive Samples</u>		<u>AVERAGES OF EACH HALF (End Points of Line)</u>	
$\bar{X}$	$\bar{Y}$	$\bar{X}$	$\bar{Y}$	$\bar{X}$	$\bar{Y}$
4.5	45.58689	9.5	40.42934	24.5	25.51836
14.5	35.27179	29.5	20.46093	74.5	-24.51836
24.5	25.87178	49.5	.61302		
34.5	15.05009	69.5	-19.47466		
44.5	5.81243	89.5	-39.52864		
54.5	-4.58638				
64.5	-14.43884				
74.5	-24.51048				
84.5	-34.61079				
94.5	-44.44648				
X-Intercept	Slope	X-Intercept	Slope	X-Intercept	Slope
49.99992	-1.00015	50.00037	-.99926	49.99963	-1.00073

TABLE 3. TEST SET NO. 1

<u>LEAST SQUARES SOLUTION USING</u>				<u>STRAIGHT LINE BETWEEN TWO END POINTS SOLUTION USING</u>	
<u>Averages of Each of 5 Consecutive Samples</u>		<u>Averages of Each of 10 Consecutive Samples</u>		<u>AVERAGES OF EACH HALF (End Points of Line)</u>	
<u>Frequency</u>	<u>Voltage</u>	<u>Frequency</u>	<u>Voltage</u>	<u>Frequency</u>	<u>Voltage</u>
299.910	37.6	299.923	32.0	299.9475	21.5
299.935	26.4	299.972	11.0	300.0475	-21.95
299.960	16.0	300.022	-10.9		
299.985	6.0	300.072	-33.0		
300.010	-5.8				
300.035	-16.0				
300.060	-27.0				
300.085	-39.0				
X-Intercept	Slope	X-Intercept	Slope	X-Intercept	Slope
299.99698	-433.80938	299.99698	-433.79977	299.99698	-434.50000



TABLE 4. TEST SET NO. 2

LEAST SQUARES SOLUTION USING

STRAIGHT LINE BETWEEN  
TWO END POINTS SOLUTION USING

<u>Averages of Each of 5 Consecutive Samples</u>		<u>Averages of Each Half (End Points of Line)</u>	
Frequency	Voltage	$\bar{X}$	$\bar{Y}$
299.920	33.6	299.94500	21.90000
299.970	10.2		
300.020	-5.6	300.04500	-16.70000
300.070	-27.8		
X-Intercept	Slope	X-Intercept	Slope
300.00150	-400.00002	300.00174	-386.00000

TABLE 5

Least Squares Solution Using All Data Samples

<u>Hypothetical Data</u>	
X-Intercept	Slope
49.99981	-1.00039
<u>Test Set Number 1</u>	
299.99691	-434.63343
<u>Test Set Number 2</u>	
300.00117	-405.58409

APPENDIX A

LEAST SQUARES SOLUTION  
HYPOTHETICAL DATA + RANDOM NUMBERS

<u>X</u>	<u>X-INTERCEPT</u>	<u>SLOPE</u>	<u>N</u>
0,1,2,.....,99	49.99981	-1.00039	100
0,2,4,.....,98	50.04974	-.99684	50
1,3,5,.....,99	49.95376	-1.00389	50
0,3,6,.....,99	51.48230	-1.09439	33
0,5,10,.....,95	50.15983	-1.00213	20
0,10,20,.....,90	49.85273	-.99125	10

Least Squares Solution  
Hypothetical Data + Normalized Random Numbers  
X = 0, 10, 20, ....., 90 Omitted  
N = 99

<u>Omit X</u>	<u>X-intercept</u>	<u>Slope</u>
0	50.00038	-1.00042
10	50.01663	-1.00121
20	50.00284	-1.00050
30	50.00769	-1.00058
40	49.99136	-1.00029
50	50.01514	-1.00038
60	49.98716	-1.00055
70	49.99263	-1.00056
80	49.98575	-1.00090
90	50.01784	-0.99953

Least Squares Solution  
Hypothetical Data and Normalized Random Numbers  
Randomly Selected Point Omitted  
N = 99

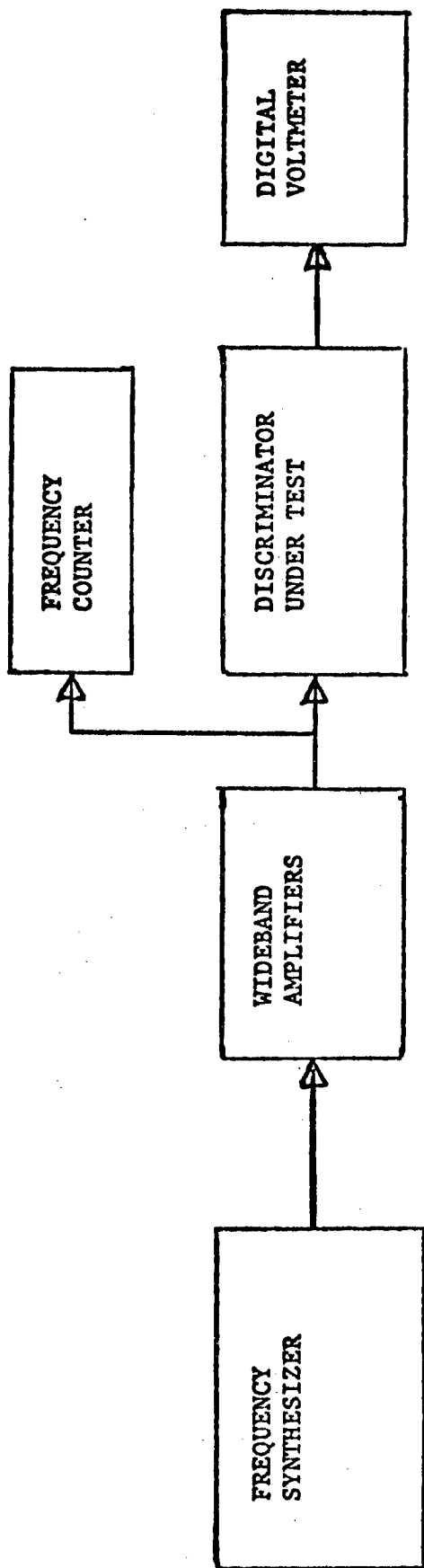
<u>Omit X</u>	<u>X-intercept</u>	<u>Slope</u>
56	50.00985	-1.00031
46	49.98573	-1.00033
29	49.98723	-1.00008
14	50.00161	-1.00047
12	50.00397	-1.00058
97	50.00648	-1.00002
17	50.01115	-1.00084
4	50.00923	-1.00092
79	50.00599	-1.00017
60	49.98716	-1.00055

LEAST SQUARES SOLUTION  
 HYPOTHETICAL DATA + RANDOM NUMBERS  
 OMIT SERIES OF FIVE VALUES  
 N = 95

<u>Omit X</u>	<u>X-Intercept</u>	<u>Slope</u>
0-4	49.99346	-.99998
10-14	50.01240	-1.00101
20-24	50.00259	-1.00049
30-34	50.03673	-1.00119
40-44	49.98093	-1.00025
50-54	50.00376	-1.00040
60-64	49.96250	-1.00093
70-74	49.98099	-1.00090
80-84	50.02216	-.99949
90-94	49.97216	-1.00188

Least Squares Solution  
 of  
 Sets of Sequential Points  
 Hypothetical Data and Normalized Random Numbers

<u>X</u>	<u>X-Intercept</u>	<u>Slope</u>	<u>N</u>
0-30	50.30710	-.99269	31
39-59	50.09299	-1.03749	21
34-64	50.15715	-.98349	31
44-54	50.07964	-1.12965	11
69-99	49.78529	-.99515	31



Block Diagram for Discriminator Experiments.

Table 1. Frequency (5 cycle interval) and voltage data obtained with a Phase Lock Loop Discriminator.

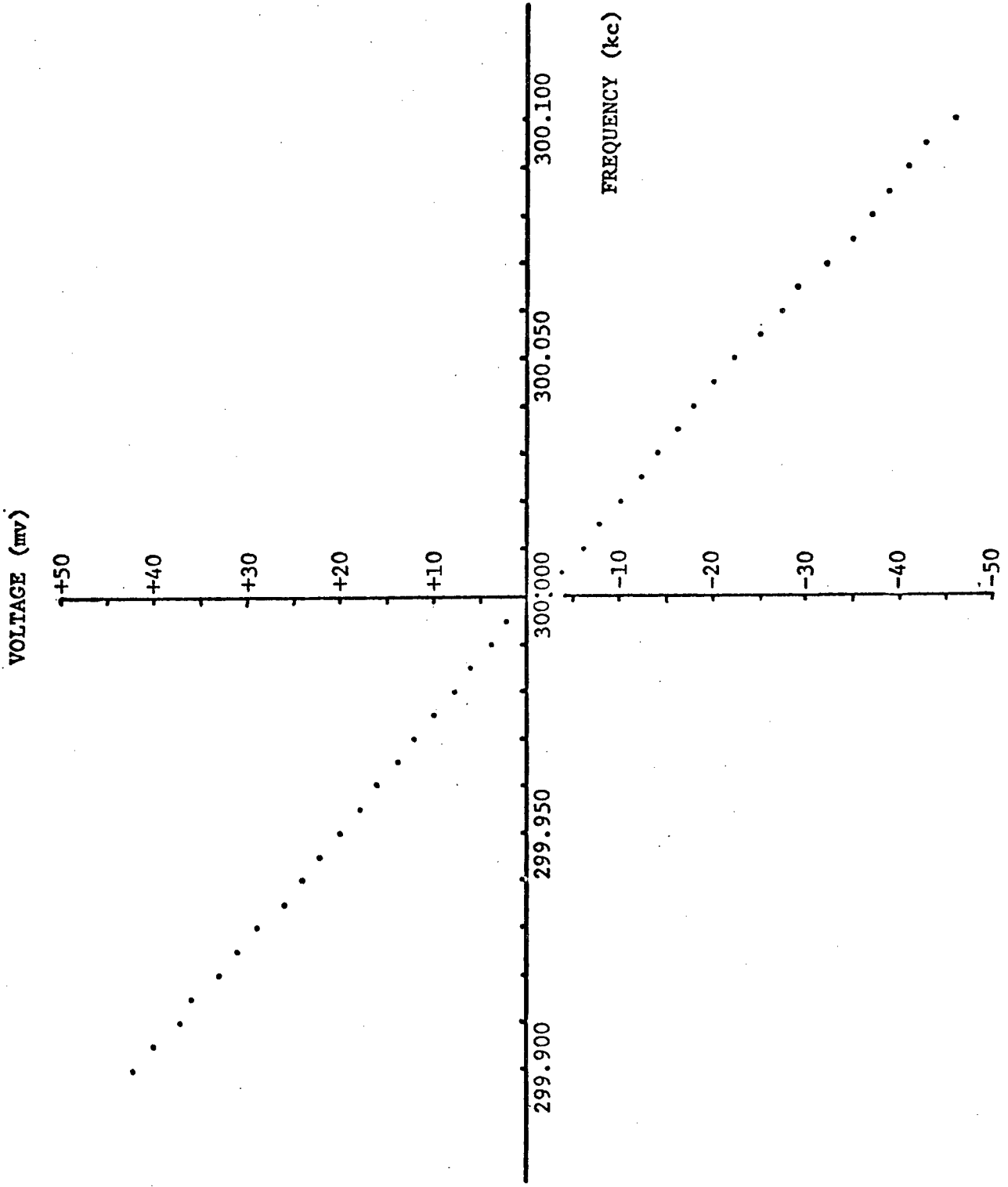
<u>Frequency (kc)</u>	<u>Voltage (mv)</u>	<u>Frequency (kc)</u>	<u>Voltage (mv)</u>
299.900	+ 42	300.000	- 1
299.905	+ 40	300.005	- 4
299.910	+ 37	300.010	- 6
299.915	+ 36	300.015	- 8
299.920	+ 33	300.020	- 10
299.925	+ 31	300.025	- 12
299.930	+ 29	300.030	- 14
299.935	+ 26	300.035	- 16
299.940	+ 24	300.040	- 18
299.945	+ 22	300.045	- 20
299.950	+ 20	300.050	- 22
299.955	+ 18	300.055	- 25
299.960	+ 16	300.060	- 27
299.965	+ 14	300.065	- 29
299.970	+ 12	300.070	- 32
299.975	+ 10	300.075	- 35
299.980	+ 8	300.080	- 37
299.985	+ 6	300.085	- 39
299.990	+ 4	300.090	- 41
299.995	+ 2	300.095	- 43
		300.100	- 46

Table 2. Frequency (10 cycle interval) and voltage data obtained with a Phase Lock Loop Discriminator.

<u>Frequency (kc)</u>	<u>Voltage (mv)</u>
299.900	+ 42
299.910	+ 39
299.920	+ 34
299.930	+ 29
299.940	+ 24
299.950	+ 20
299.960	+ 15
299.970	+ 10
299.980	+ 5
299.990	+ 1
300.000	+ 0
300.010	- 0
300.020	- 4
300.030	- 10
300.040	- 14
300.050	- 19
300.060	- 23
300.070	- 28
300.080	- 32
300.090	- 37
300.100	- 42

Table 3. Frequency (100 cycle interval) and voltage data obtained with a Pulse Type Discriminator.

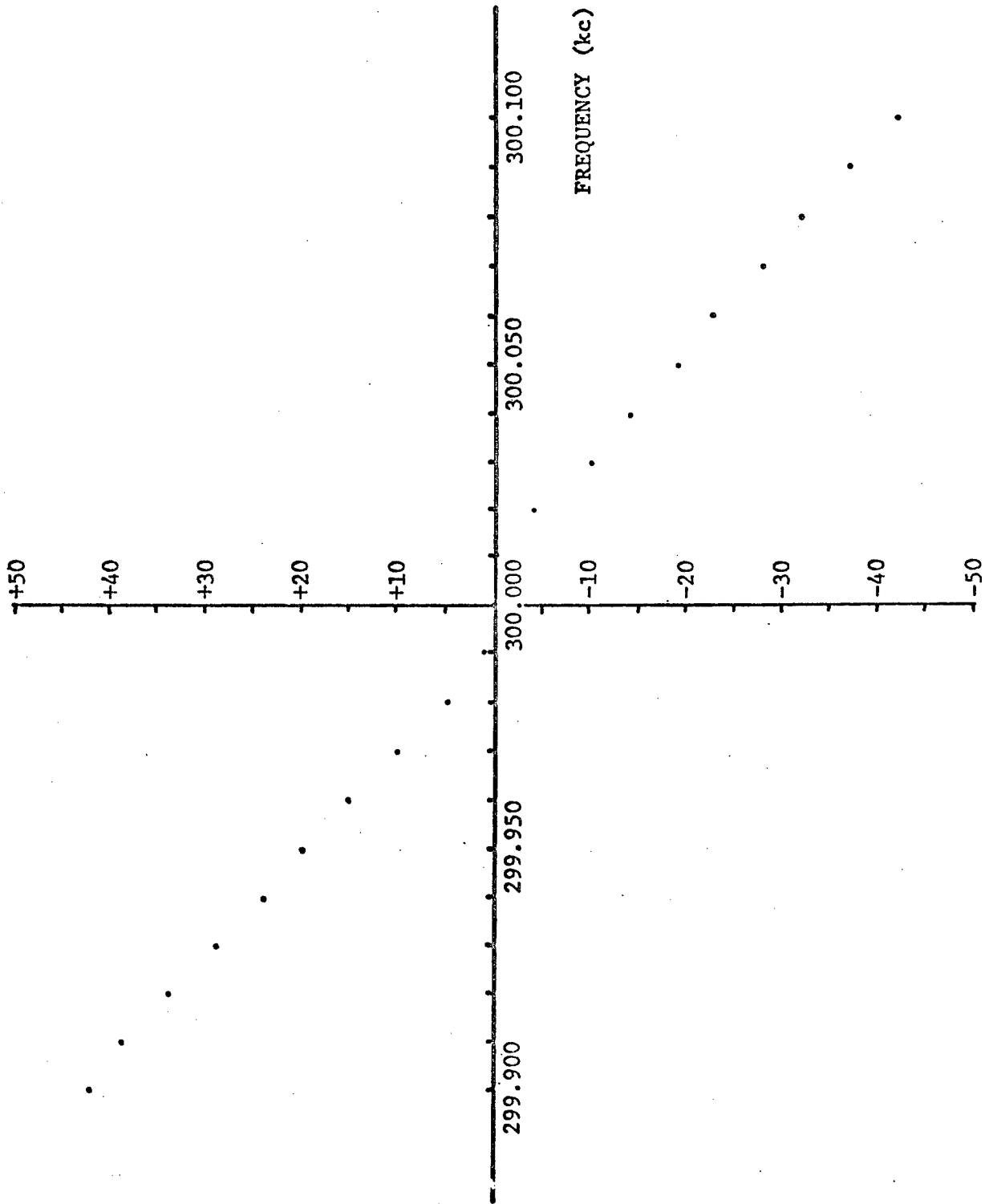
<u>Frequency (kc)</u>	<u>Voltage (volts)</u>
499.000	5.068
499.100	5.069
499.200	5.070
499.300	5.071
499.400	5.072
499.500	5.073
499.600	5.074
499.700	5.075
499.800	5.076
499.900	5.077
500.000	5.078
500.100	5.079
500.200	5.080
500.300	5.081
500.400	5.082
500.500	5.083
500.600	5.084
500.700	5.085
500.800	5.086
500.900	5.087
501.000	5.088



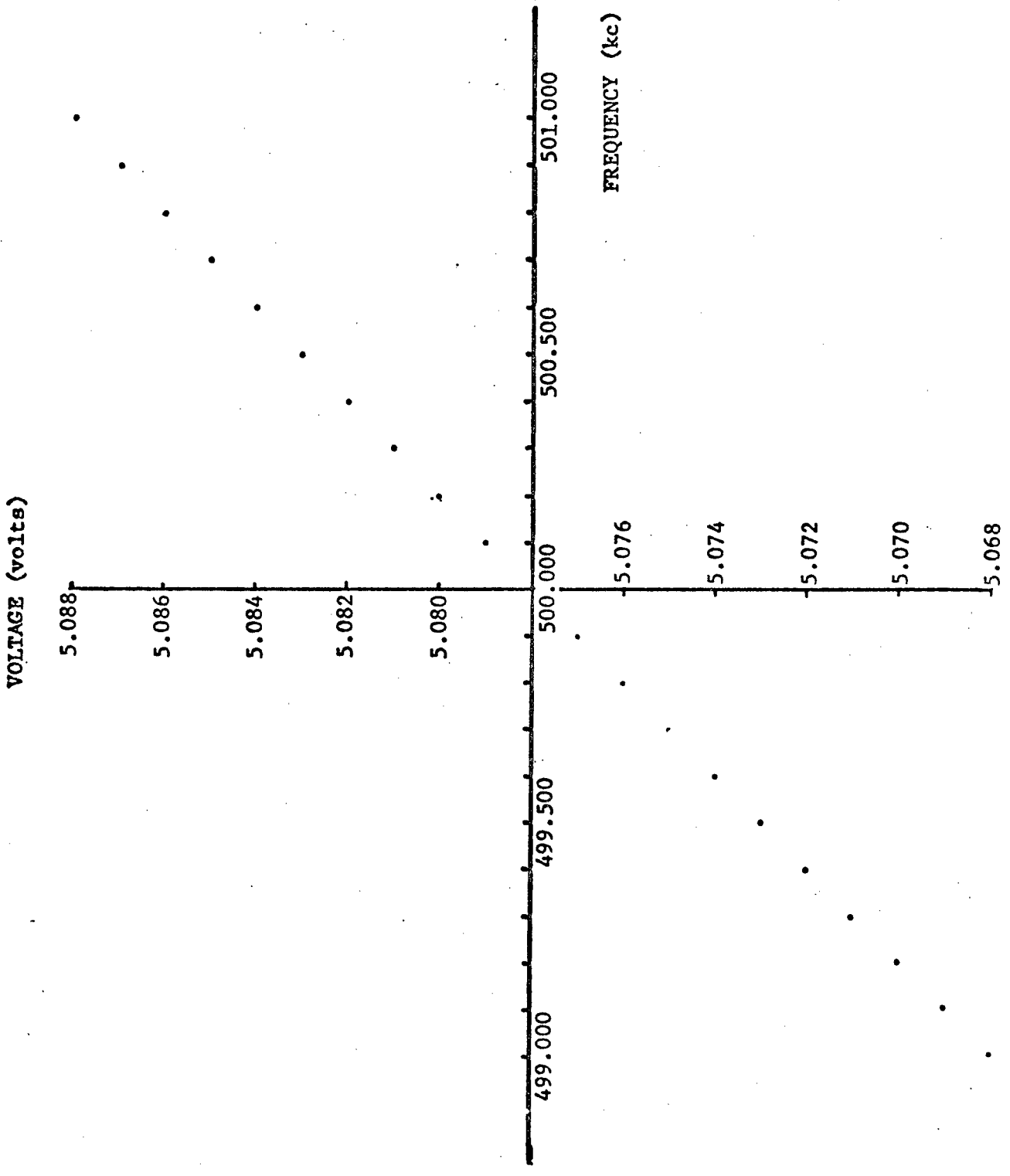
Plot of data from Table 1 showing linear response of Discriminator measurements with noise.



VOLTAGE (mv)



Plot of data from Table 2 showing linear response of Discriminator measurement with rare ( one time ) occurrence of an apparent shift in response characteristic in the vicinity of zero-doppler ( 300.000 kc ) and zero voltage.



Plot of data from Table 3 showing perfect linear response of Discriminator to input frequency.

# A STATISTICAL APPROACH TO LOADING AND FAILURE OF STRUCTURES\*

Ronald G. Merritt

U. S. Army Corps of Engineers  
Construction Engineering Research Laboratory  
Champaign, Illinois

ABSTRACT. It is becoming increasingly important to examine available data on structural behavior in the assessment of design criteria. To this end a rationale for examination and selection of loading criteria based upon available data is proposed. The rationale is based upon examination of both structural load data and structural failure data. This paper examines in some detail the assessment of structural failure data and extends some of the same ideas to structural load data. In order to extract information content from collected data, a class of statistical methods applicable to the data has been selected. A matrix correlating data parameters with statistical method is developed. A method for assessing the overall information content of the collected data is proposed. Finally recommendations are made for future collection and correlation of load and failure data.

1. INTRODUCTION: A fundamental problem of structural engineering is the examination and selection of loading criteria. It is imperative that any solution to the problem center around a rationale that relates information available on loading to selected criteria. Such available information is generally in the form of data. It is the purpose of this brief paper to abstract the problem and outline preliminary work on a rationale for addressing the problem.

The paper begins by defining the general nature of the problem. Solution to the problem is related to consideration of available information in the form of data. The next three sections of the paper discuss the initial stages of a rationale for consistent examination and selection of loading criteria. The first of the sections examines available information on structural load and the second examines available information on instances of structural failure. Classes of statistical methods are discussed in the third section. This section also includes discussion of a proposed method for assessing the overall information content of the available data. Finally, an illustrative example of application of a statistical method to loading data is presented and the paper concludes with a discussion of future extension to this preliminary work.

---

\* "The views of the author do not purport to reflect the position of the Department of the Army or the Department of Defense."

2. GENERAL NATURE OF THE PROBLEM. Examination and selection of loading criteria involves the consideration of a statement S with quantifiers that relate variables useful in description of the load. This may be written generally as

$$S: C = C(\bar{t}, \bar{r}, \bar{a}) \quad (1)$$

for

S - loading criteria statement  
C - load function  
 $\bar{t}$  - time vector  
 $\bar{r}$  - space vector  
 $\bar{a}$  - parameter vector

The statement S has as quantifier the load function C which is expressible in terms of time, space and a finite set of parameters. The expression is general enough to allow for several components of time, space and parameters as denoted by the vector notation. The problem may now be stated in terms of examination of the validity of S.

Validity of S is usually established through some subjective and objective evaluation of available information related to S. In order to be consistent in this evaluation of information a rationale for carrying out this evaluation must be set forth. The preliminary outline of the rationale proposed in this paper centers upon a means of assessing available information related to S by use of statistical techniques, correlating this information and obtaining quantitative factors upon which the validity or invalidity of S may be established. In a real sense this rationale in part already exists in that statistical interpretation of collected data is common place in examination of load data. The discussion to follow extends this rationale. However, it is important to note here that "all" available information is to be examined in evaluating the validity or invalidity of S. This includes consideration of load information for one. In addition, since the invalidity of S tacitly implies possibility of structural failure because of load, one must also consider structural failure information. It is the general nature of these sets of information that provides the basis for this preliminary work on development of the rationale.

3. LOAD INFORMATION. Load information is obtained in a quantity termed a datum. Such datum may be in a raw form or in a summary form. The raw form consists of the most basic unit and results from direct quantization of the phenomenon under observation. The summary form results from a transformation of the raw datum.

Upon collection of data on loading e.g., wind loading, it becomes apparent that some way of classifying individual pieces of datum needs to be developed. Once classified then groups of datum within any one designated category could be examined for consistency and their relationship to the proposed loading criteria. The discussion to follow defines the datum classification system and the example in Section 6 illustrates application of a statistical technique to a piece of datum within the system.

The requirements on a load data classification system are very basic. First, a single piece of datum must be recognized as such in the system and second a piece of datum must be classifiable within the system. In order to facilitate this a "generalized random process",  $L$ , is defined whose "sample functions" consist of pieces of datum described by a set of parameters related to the load phenomenon<sup>1\*</sup>. This is most easily expressed as

$$L(\bar{t}, \bar{r}, \bar{a}) = \{l(\bar{t}, \bar{r}, \bar{a}) : \bar{t} \in T, \bar{r} \in R, \bar{a} \in A\} \quad (2)$$

where

$L(\bar{t}, \bar{r}, \bar{a})$  - generalized random process

$l(\bar{t}, \bar{r}, \bar{a})$  - a piece of datum

$\bar{t}$  - time related description of the datum

$T$  - time indexing set

$\bar{r}$  - space related description of the datum

$R$  - space indexing set

$\bar{a}$  - parameter related description of the datum

$A$  - parameter indexing set.

It is assumed that every piece of datum related to a load phenomenon belongs to  $L(\bar{t}, \bar{r}, \bar{a})$  and that each piece of datum is uniquely defined through an ordered triple of vectors  $(\bar{t}, \bar{r}, \bar{a})$ .

The advantages of such a means of classifying data by evaluation of  $\bar{t}$ ,  $\bar{r}$  and  $\bar{a}$  are readily apparent. First, in evaluation of  $\bar{t}$ ,  $\bar{r}$  and  $\bar{a}$  datum sets are established within  $L(\bar{t}, \bar{r}, \bar{a})$  that relate similar information about the load phenomenon under investigation. Second, correlation of information through evaluation of  $\bar{t}$ ,  $\bar{r}$  and  $\bar{a}$  allows one to assess the overall information content of the available data. Third, ready evaluation of data within a given datum set is possible and links amongst datum sets provide a key to links amongst data within different datum sets. Finally, this approach lends itself well to either the synthesis approach or the analytical approach to criteria selection. In the synthesis approach all data is structured into a description of the load phenomenon and criteria are selected from this description. In the analytical approach the datum is checked against the proposed criteria for consistency and selection of criteria is based upon this check. In either case the pertinent datum is easily identified.

A total of twenty-two parameters that must be evaluated for each piece of datum are selected. The twenty-two parameters may be divided into five groups. Brief mention of these five groups will suffice for the present discussion. The first group consisting of two parameters uniquely identifies the piece of datum. The second group consisting of five parameters identifies the datum by defining the overall load phenomenon properties, e. g. static, deterministic, stationarity, source, spatial extent. The third group consisting eight parameters describes the piece of datum in terms of the time

---

\* Elevated numbers denote references.

history information available. The fourth group consisting of five parameters describes the datum in terms of the spectral information available. Finally the fifth group of parameters consisting of two parameters gives a brief narrative description of the piece of datum along with a source reference.

This general scheme of datum referencing permits a consistent examination of structural load data and allows for easy construction of a structural load data base.

4. STRUCTURAL FAILURE INFORMATION. The consideration of data on instances of structural failure in the preliminary stages of development has provided for some most interesting ideas on structuring of data from diverse and complex phenomenon. In the case of structural load data, the content of individual pieces of datum is described in terms of a set of parameters and the raw or summary form data is contained within each of the random process sample functions. Data analysis was assumed to take place on a "level below" the datum structure,  $L(\bar{t}, \bar{r}, \bar{a})$ . For the case of structural failure the nature of the available data and information desired from the data requires that the description of the datum i.e., instance of structural failure, be complete enough for data analysis on the datum structure level. That is, the analogous structural failure "generalized random process" should contain all the available information concerning the structural failure. This approach to structural failure datum is the product of several considerations. First, quantitative structural failure data is difficult to obtain since few instances of structural failure are instrumented. Second, unless the failure is controlled in some manner, quantitative data tends to be meaningless because of the complex load-response path that usually describes the failure. Third, any one case of structural failure is but one of many possible structural failures and it may or may not share properties in common with other cases of structural failure. Fourth, detailed quantitative data from instrumentation of a structural failure would present a prohibitively high collection and reduction cost to information ratio. Finally, detailed reduction of quantitative data obtained during or after structural failure would tend to de-emphasize the overall characteristics of the structural failure. Thus, structural failure data is considered in the following way.

It was hypothesized that structural failure may be considered a "generalized random process"<sup>1</sup>. Thus, it may be represented by an expression

$$S(\bar{t}, \bar{r}, \bar{a}) = \{s(\bar{t}, \bar{r}, \bar{a}); \bar{t} \in T, \bar{r} \in R, \bar{a} \in A\} \quad (3)$$

$S(\bar{t}, \bar{r}, \bar{a})$  - structural failure generalized random process

$s(\bar{t}, \bar{r}, \bar{a})$  - structural failure sample function

$\bar{t}$  - time vector

$T$  - time indexing set

$\bar{r}$  - spatial vector

$R$  - spatial indexing set

$\bar{a}$  - parameter vector

$A$  - parameter indexing set.

All instances of structural failure belong to  $S(\bar{T}, \bar{r}, \bar{a})$  and every failure is in  $S(\bar{T}, \bar{r}, \bar{a})$  either explicitly through collected data and parameter evaluation or implicitly in cases where the structural failure is unrecorded but the indexing sets are broad enough for the description. The problem of structural failure data structuring now becomes a matter of defining T, R and A and evaluating  $\bar{T}$ ,  $\bar{r}$  and  $\bar{a}$  from collected data on structural failure.

Forty-five parameters are considered adequate to define the structural failure random process, i.e., forty-five parameters are considered sufficient to describe any instance of structural failure. Obviously, only the overall gross characteristics of an instance of structural failure are considered appropriate for description and most pertinent to the overall rationale.

The forty-five parameters fall into nine major categories. For the sake of brevity these nine major categories will be listed with a few comments regarding the parameters within each category.

1. identification - This category includes information on the source and information content of the structural failure data available.
2. structure characteristic information - This category includes all information related to the structure that experienced the failure. The dates of construction and failure are recorded along with the general structural, material and functional characteristics of the structure. The geometrical dimensions of the structure along with those of the failed portion of the structure are also recorded.
3. general failure description - This category describes the cause of the failure, the extent of the failure both in qualitative and quantitative terms, the nature of the failure in terms of its possible progressive or nonprogressive characteristics, horizontal or vertical characteristics, the total time of the failure and the stages of the failure.
4. global failure description - For failures in which a major portion of the overall structure has failed the failure takes on a global nature. This is subsequently described by three parameters naming elements of the structures that failed, modes of failure, and material composing the failed elements of the structure.
5. local failure description - A failure of a structure may include a small portion of the overall structure in which case the failure takes on a local nature. The same three parameters as for the global failure description provide for the local failure description.
6. global load description - Loading on a structure that is over a large portion of the structure may be termed a global load. It is described in terms of four parameters including identification, general dimensions, a general statement and estimated value if this is available or able to be deduced.

7. local load description - Loading on a structure that is over a small portion of the structure may be termed a local load. The same four parameters as in the case of global load description describe the local load.
8. load - failure relationship - In most instances of structural failure there exists a general spatial relationship between load and failure. This relationship may be expressed in terms of local load - local failure, global load - local failure, local load - global failure, global load - global failure. This parameter provides insight into the nature of the extent of the loading and the corresponding failure.
9. general statement - This final parameter group consisting of one parameter is a general statement about the failure and its cause.

Here again it is well to take note that structural failure does not relate well to phenomenological description because of its complexity. The categories of parameters and the parameters themselves provide for an overall view of the structural failure process. Given data on structural failure the parameters of  $S(\bar{t}, \bar{r}, \bar{a})$  can be evaluated and  $S(\bar{t}, \bar{r}, \bar{a})$  better defined. The statistical techniques to be discussed in the next section are applied directly to the parameters of  $S(\bar{t}, \bar{r}, \bar{a})$ .

5. BASIC CONSIDERATIONS FOR STATISTICAL ANALYSIS. The nature of the problem under consideration and the number of statistical techniques applicable to the problem make it possible to consider only a few topics in relating statistical methods to the datum within the framework of the load and failure generalized random processes discussed above.

One of the first considerations in applying statistical methods to data defining the processes above is an examination of the way in which the data is measured. There exist four acceptable statistical data measures by which the measure of data is defined<sup>2,3</sup>. Listed in order from least to most powerful they are as follows: nominal, ordinal, interval and ratio. A brief description of each is in order. The nominal measure applied to data implies the data may be categorized according to a set of mutually exclusive conditions. The ordinal data measure applied to data implies there exists an order relationship amongst pieces of the datum. The interval data measure applied to data implies a relationship of the form

$$x - y > 0, x - y = 0 \text{ or } x - y < 0 \quad (4)$$

exists between any two pieces of datum. Finally, the ratio data measure applied to data implies numerical relationships for the datum are available and for  $y \neq 0$ ,  $x/y$  is a meaningful expression between any two pieces of datum.

Although there are a number of ways of dividing statistical methods into categories for purposes of this discussion, perhaps the categories distribution and distribution free will suffice. Distribution related statistical methods in general correlate with instances in which distribution functions with a finite



number of parameters may be utilized in the statistical analysis of the data. Distribution free related statistical methods in general correlate with instances in which lesser restrictions are imposed upon conditions that must be satisfied for application of the method to a given set of data. These statistical methods may be further subdivided into methods concerned with point estimates of parameters, confidence regions for parameters or significance tests for parameters.

In the illustrative example to follow a distribution free statistical method is applied to a piece of load datum. In general distribution related methods apply well to load data because of its tendency to be describable in terms of the ratio data measure and distribution free related statistical methods apply well to structural failure data because of its tendency to be describable in terms of data measures less powerful than the ratio measure.

In work to date emphasis has been placed on consideration of structural failure data. It has become important to consider categorical distribution free statistical techniques for use on parameters of the structural failure random process. Categorical techniques are most applicable because structural failure data is for the most part of a categorical nature. Distribution free techniques are most applicable because of the difficulty in determining the distributions and their related parameters resulting from unavailability of large amounts of data.

It is found useful when considering the structural failure generalized random process to construct a statistical method - process parameter matrix whereby statistical methods applicable to given process parameters are correlated one to another. Table 1 below provides a segment of this matrix.

SM \ FP	1	2	3	4	5	Key:	
						Failure Parameter (FP)	Statistical Method (SM)
6	X	X	X			6 descriptive name	1 binominal test
7	X	X		X		7 construction date	2 chi-square test for goodness of fit
8	X	X		X		8 failure date	3 Wald - Wolfowitz run tes
9						9 structural	4 quantile test

Table 1: Statistical Method - Failure Process Parameter Matrix

The construction of the matrix in Table 1 leads naturally to an assessment of the overall information content of a set of data based upon an evaluation of factors useful in defining the overall characteristics of a statistical method<sup>4</sup>. Table 2 lists factors useful in evaluating the effectiveness of a statistical method along with proposed weights for these factors. The overall information content of a set of data is determined by associating a set of statistical techniques with the data and proceeding to tabulate weight values for the various factors. A relative measure of information content amongst sets of data is obtained.

statistical data measure	(10)
nominal	2
ordinal	4
interval	6
ratio	10
sample size	10
data transformation and restrictions on data parameters	2
level of computational effort	2
extent of use of symmetry	2
sensitivity of procedure to assumptions	4
precision level	(10)
exact	10
theoretical approximate	7
judgment empirical	4
efficiency of method	10
consistency of method	10
sensitivity of procedure to assumptions and difficulty in verifying assumptions	10
population properties and importance amongst other data groups	5

Table 2: Factors for Evaluating the Effectiveness of a Statistical Method with Weights

There exist several major weaknesses in the approach. First, not all statistical methods may be accurately evaluated in terms of these factors. Second, it presumes that one has selected an optimal set of statistical methods to operate on a given set of statistical data. Third, it presumes that data information content is related to abstract measures on the statistical method independent of the data. Finally, it assumes the weighting factors are accurate and constant over the ranges of statistical methods. Despite these weaknesses a matrix relating statistical method versus weighting factor provides for a crude measure of the relative information content of a set of data to which the statistical method may be applied.

6. AN ILLUSTRATIVE EXAMPLE. The example in this section of the paper is illustrative in the sense that (a) it is not based upon all the data that is available and (b) it presents a rather new approach in the reduction of civil engineering data. The first point is a result of the preliminary nature of this work and ability to reduce only a portion of the data available. The second point refers to the use of distribution free statistical techniques on the selected data. In general, measurement distribution oriented statistical techniques are used on numerical data resulting from a well controlled experiment. The results of the statistical analysis are then presented in some concise form. Distribution free statistical techniques are often times related to a statistical hypothesis test that may or may not be associated with parameters describing the data e.g., trend or randomness of data may be under investigation.

It is also well to point out that the conclusions drawn from the illustrative example may seem trivial, however, each example conclusion presents only a minute piece of information extending that which is already known about the case under investigation. That is to say, the effectiveness in use of techniques in this way comes by way of construction of an overall view of the case by means of statistics. This implies application of many statistical techniques in many different ways to the data available. Fortunately, once a data base has been constructed and the statistical techniques selected, this becomes a rather simple and automatic procedure.

The illustrative example presented here concerns investigation of the relationship between the set of values from "collected data" and the set of values assigned by a criteria statement. In the context of the previous discussion, Table 3 provides a statement of structural loading criteria.

Criteria: Following table for average pressure coefficients shall be used for calculating pressures on external surfaces of buildings.

Location of Wall	$C_{pe}$
Windward wall	0.8
Leeward wall, both height-width and height-length ratios $\geq 2.5$	-0.6
Other buildings	-0.5
Side Walls	-0.7

Table 3: Criteria for External Pressure Coefficients for Walls,  $C_p$ <sup>5</sup>

Some of the data related to this criteria acquired from wind tunnel testing is provided in Table 4. In this table the external pressure coefficient on a structures wall is tabulated for two angles of incidence ( $0^\circ$  and  $45^\circ$ ) to the building wall A with the unprimed letters representing data for building sides of  $0^\circ$  of incidence and the primed letters representing data for building sides of  $45^\circ$  of incidence.

h:b:L	$\alpha = 0^\circ$				$\alpha = 45^\circ$			
	A	B	C	D	A'	B'	C'	D'
1:1:1	.9	-.5	-.6	-.6	.5	-.5	.5	-.5
2.5:2:5	.9	-.5	-.7	-.7	.6	-.5	.4	-.5
2.5:2:5	.9	-.5	-.7	-.7	.6	-.5	.4	-.4
2.5:2:5	.9	-.5	-.8	-.8	.6	-.5	.4	-.4
1:4:4	.9	-.3	-.4	-.4	.5	-.4	.5	-.4
1:8:16	.8	-.5	-.5	-.5	.5	-.5	.4	-.3
2.5:1:1	.9	-.6	-.7	-.7	.5	-.5	.5	-.5
2:1:2	.9	-.5	-.8	-.8	.6	-.5	.4	-.4
1:2.4:12	.9	-.5	-.6	-.6	.5	-.6	.4	-.4
1:1:5	.9	-.5	-.6	-.6	.5	-.8	.4	-.5

Table 4: Structural Configuration and External Pressure Coefficient  $C_{pe}$  at Angles of Incidence of  $0^\circ$  and  $45^\circ$

For this illustrative example it is to be determined if there is a significant difference between the numbers representing the criteria and those derived from the small amount of available wind tunnel data. This is perhaps better stated by inquiring of some statistical measure of the representation of the wind tunnel data by the criteria. However, it is important to note here that the numbers of Table 3 and Table 4 do not represent random sample values from a general population. For this illustrative example it is assumed that there exist ten categories of structural configuration defined by the h, b, L ratios of Table 4. In addition it is assumed that initially a number of structures in each category are designed on the basis of the data of Table 4. At a later date the same number of structures in the respective categories are designed on the basis of data of Table 3. There exists then a population of designs  $P_1$  associated with Table 3 and a population of designs  $P_2$  associated with Table 4. Suppose then a random sample of designs is taken from  $P_1$  and  $P_2$  being careful to select one and only one design from each category of the two populations. In effect then the tabulation of design values for  $C_{pe}$  from population  $P_2$  results in Table 4 and to each value of Table 4 corresponds a value of Table 3. From this discussion, one may surmise that the example is quite artificial, however, one must note the objective of the consideration is to determine in some statistical way the difference between a statement of criteria and a small amount of data available for evaluating the criteria. As a matter of fact the small amount of available data may have been used in engendering the criteria.

The "statistical measure" for examining the difference in the artificial constructed populations  $P_1$  and  $P_2$  is the Wilcoxon signed rank test<sup>2,7</sup>. This test is very likely not the most effective test that might be applied in this instance, however, it is easy to apply and should yield some information relative to the question being asked. The test assumes samples of paired replicates with a model defined by

$$Z_i = Y_i - X_i = \theta + e_i \quad i = 1, \dots, n \quad (5)$$

where

- $Y_i$  - sample values from population  $P_2$
- $X_i$  - sample values from population  $P_1$
- $\theta$  - unknown parameter of interest ("treatment" effect)
- $e_i$  - unobservable mutually independent random variables from a continuous population symmetric about 0

The hypothesis to be tested is

$$H_0 : \theta = 0 \text{ against the alternative hypothesis } H_1 : \theta \neq 0 \quad (6)$$

If the hypothesis is accepted at a prescribed level the criteria of Table 3 will be considered an adequate representation for the data of Table 4 and if the hypothesis is rejected the criteria will be considered inadequate for representation of the data. It should be cautioned that (1) a level of significance for the test is somewhat arbitrary at this point and no specific

guidance is available for selection of a level that will provide a solid confidence in acceptance or rejection of  $H_0$  and (2) the data is not complete. Utilizing the test statistic  $T^+$  for small samples and  $T^*$  for large samples where

$$T^+ = \sum_{i=1}^n R_i \psi_i \quad (7)$$

$R_i$  - the rank of  $|Z_i|$   $i = 1, n$   
 $\psi_i = \begin{cases} 1 & \text{if } Z_i > 0 \\ 0 & \text{if } Z_i < 0 \end{cases}$   
 $n$  - the sample size

and

$$T^* = \frac{T^+ - [n(n+1)/4]}{[[n(n+1)(2n+1) - \frac{1}{2} \sum_j^g t_j(t_j-1)(t_j+1)]/24]^{1/2}} \quad (8)$$

$g$  - number of tied groups  
 $t_j$  - size of the tied group  $j$ .

Selecting the level of significance to be 0.01 and considering various combinations of the data of Table 4 matched with the criteria of Table 3 the results are tabulated in Table 5.

Criteria against	n	$T^*$ or $T^+$	Decision
A	9	45	reject $H_0$
B	1	1	no table values
C	7	22	accept $H_0$
D	7	22	accept $H_0$
A'	10	0	reject $H_0$
B'	4	4	accept $H_0$
C'	10	55	reject $H_0$
D'	10	55	reject $H_0$
ABCD	24	3.34	reject $H_0$
A'B'C'D'	34	2.64	reject $H_0$

Table 5: Tabulation of Statistics and Decision for the Wilcoxon Signed Rank Test for  $\alpha = 0.01$  (two tail test) for Criteria and Data on the External Pressure Coefficient.

It will be noted that the criteria is apparently an adequate description for C in three of the nine cases tested. Again some caution needs to be exercised in drawing conclusions from the illustrative example since there is little guidance available on levels of test significance and the limited amount of data.

7. CONCLUSION. The above represents a very preliminary basis for a statistical examination of the load and failure of structures and a rational approach to examining available information related to loading criteria. The next stage in the development will consider construction of a data base of available data along with establishing a broader group of statistical techniques. This should lead to the consideration of mathematical pattern language in the correlation of collected data and in the utilization of appropriate statistical techniques on the collected data. In addition it is anticipated that more advanced mathematical techniques e.g., in the area of combinatorial methods will be used for investigating general relationships amongst the diverse pieces of datum.

The ideas expressed above form a basis for a rationale for the examination and selection of load criteria. The rationale is based upon a consistent and thorough statistical analysis of available load data and failure data. Given the statement S representative of a statement of load criteria the validity of S is deduced from the consistent and thorough statistical analysis of all available data. Work to date described above is a first step in the rationale development.

#### Acknowledgement

The author would like to express his appreciation to Dr. W. E. Fisher of the Structural Mechanics Branch at CERL and CERL for their support during this study.

#### References

1. Merritt, R. G., "A Statistical Approach to Loading and Failure of Structures," CERL Technical Report to be published.
2. Conover, W. J., Practical Nonparametric Statistics, John Wiley and Sons, Inc., 1971.
3. Stevens, S. S., "On the Theory of Scales of Measurements," Science, 103, pp. 677-680.
4. Walsh, J. E., Handbook of Nonparametric Statistics, Vol. I. D. VanNostrand Company, Inc., 1962.
5. "American National Standard Building Code Requirements for Minimum Design Loads in Buildings and Other Structures" ANSI A58.1 - 1972 American National Standards Institute Inc. New York, New York 1972.
6. Wind Forces on Structures, Final Report, Task Committee on Wind Forces Committee on Loads and Stresses, ASCE Paper No. 3269, Transactions of ASCE, Vol. 126, Part II, 1961, pp. 1124-1198.
7. Hollander, M., and Wolfe D., Nonparametric Statistical Methods, John Wiley and Sons Inc. 1973.

## STRAIN GAGE INSTRUMENTATION FOR AMMUNITION TESTING

Paul D. Flynn  
Pitman-Dunn Laboratory  
Frankford Arsenal  
Philadelphia, Pennsylvania

ABSTRACT. In connection with a modernization program on the manufacture of small caliber ammunition, it was recognized that ballistic pressure measurements would have to be automated in order to keep pace with increased rates of production. Copper crusher pressure gages with individual measurements of compressed cylinders would be too slow. This paper deals with a feasibility study on the use of electrical resistance strain gages for quality assurance testing of ammunition.

Although the method of using external strain gages to determine internal ballistic pressures is well known, a new arrangement of strain gages was developed to measure directly the quantity  $(\epsilon_{\theta} + \nu \epsilon_z)$  on the outer surface of a test barrel (where  $\epsilon_{\theta}$ ,  $\epsilon_z$  are the circumferential and longitudinal strains, respectively, and  $\nu$  is Poisson's ratio). From Hooke's law, the combined strain signal was proportional to the circumferential stress in the barrel at the outer surface. Using Lamé's solution, this stress was related to the internal pressure. Thus, the strain gaged test barrel acted as its own pressure transducer.

Experiments were designed to compare the results of ballistic firings with three types of ammunition, two test barrels, and pressures at several locations. It was concluded that the strain gage method is feasible for acceptance testing of ammunition.

NOTE. Published by the Society for Experimental Stress Analysis in its journal on Experimental Mechanics, Volume 15, 1975.

STATISTICAL INVESTIGATION INTO PULSE CHARGING  
OF NICKEL-CADMIUM BATTERIES

Walter Kasian  
Maintenance Directorate  
and  
Erwin Biser  
Avionics Laboratory  
U. S. Army Electronics Command  
Fort Monmouth, New Jersey

ABSTRACT. The common methods of charging vented aircraft nickel-cadmium batteries are constant current, constant potential and modified constant potential (current limited). However, through continuous recharging by these methods, nickel-cadmium batteries develop a "memory effect" caused by passivation of the battery's positive cell plate material (nickel-oxide) and "fadeout" caused by crystal growth of the negative cell plate material (cadmium). These two phenomena gradually and continually lessen battery charge acceptance which in turn lessens the battery output.

Pulse charging, however, has shown a significant effect in eliminating battery "fadeout" and "memory effect". Thus pulse charging can eliminate the required periodic cycling to rejuvenate the batteries and possibly increase the battery cycle life. The pulse charging of nickel-cadmium batteries has been completed on two new and two used batteries in all possible combinations of the following charge variables: three different pulse amplitudes, three different charge rates and two different per-cent overcharge rates.

This investigation entails analysis of the mean response (battery output) and response variability to determine the optimum combination of pulse amplitude, charge rate and per-cent overcharge in charging new and used nickel-cadmium batteries. Similar analysis is performed to determine the optimum combination of the variables for greatest battery efficiency.

1. INTRODUCTION. The Army nickel-cadmium battery, on which this investigation was performed, is nomenclatured as the BB-433()/U, is rechargeable and is rated at 34 ampere-hours; that is, it is capable of supplying 34 amperes of current at a constant rate for 1 hour at a nominal voltage of 24 volts. This is just over 800 watts of power. The battery is used primarily to start Army aircraft and to



supply power to airborne electronics equipment and the Vulcan Air Defense System.

The reason an investigation was performed on this battery is because of its high density, approximately 5,000 of these batteries are deployed and because of the severe maintenance problems encountered with these batteries. After every 100 hours of use, these batteries have to come into maintenance shops for reconditioning which can take anywhere from 20 to 30 hours if the batteries are good. The reason for periodic maintenance is necessitated by the fact that the present recharging techniques, constant current and modified constant potential, whether in a battery operating system or maintenance shop gradually lessen battery charge acceptance which in turn lessens battery output. Pulse charging however eliminates the maladies associated with constant current or constant potential charging, i.e., fadeout (cadmium crystal growth on the battery negative plates) and memory effect (passivation of the nickel-oxide on the battery positive plates).

The three different charging methods are depicted in Figure 1. As constant current implies, a constant current is applied to the battery for a specified time, usually limited to the time that the battery receives its rated capacity. In modified constant potential, the battery draws current until it is charge to a certain specified voltage. The maximum current is usually limited to the battery rating. In pulse charging, the input pulsed current can be of any amplitude with an average input value, as in this case up to the battery rating of 34 ampere-hours.

The pulse charging of the 3B-433()/U is depicted in Figure 2. The average main current ( $I_M$ ) input at any pulse amplitude is applied for a time  $T_A$ . This is the time the battery receives approximately 100% of its capacity. It is then overcharged at one-third the main current by a certain % of the time it underwent its main charge. In this case, at 20% and 40% overcharge. Because the battery is not 100% efficient, overcharging is required so that we can obtain at least 100% of the battery's rated output on discharge. The Automatic Pulse Charger, model 3000A, developed by Utah Research and Development Company specifically for the Army was employed for all the pulse chargings in this investigation.

After charging and a four hour rest period, the batteries were discharged at half their rated capacity,

17 amperes, to a battery end voltage of 19.2 volts, the point at which 100% of the battery's capacity has been removed. All charging and discharging was monitored by external test equipment to provide data accuracy to 1%. The BB-433 discharge characteristic is depicted in Figure 3.

2. STRUCTURE OF THE MODEL. This experiment consisted of the following factors: A = Peak Pulse, B = Charge Current, C = % Topping or Overcharge and D = Battery Type (new or used). The factors and the levels of these factors are described in Figure 4. Since the levels of the factors are at fixed values, the model is thus a fixed model. The values of the output (ampere-hours) and efficiencies obtained from BB-433's of two different manufacturers (batteries #1 and #2 of manufacturer X and batteries #3 and #4 of manufacturer Y) are shown in Figures 5 through 8. Two observations were obtained for each combination of the different levels. Efficiency was calculated as the ampere-hour output divided by the ampere-hour input for each battery charge - discharge cycle.

The mathematical model adopted can be expressed as follows:

$$X_{IJKL(M)} = U + A_I + B_J + C_K + D_L + AB_{IJ} + BC_{JK} + CD_{KL} + AC_{IK} + AD_{IL} + BD_{JL} + ABC_{IJK} + \dots + BCD_{JKL} + E_{IJKL(M)}$$

$$I, J : 0, 1, 2$$

$$K, L : 0, 1$$

where  $X_{IJKL(M)}$  = observed random variable (output or efficiency)

$U$  = grand average or effect due to the mean

$A_I, B_J, C_K, D_L$  = effect due to main effects

$AB_{IJ}, \dots, BCD_{JKL}$  = effect due to interactions

$E_{IJKL(M)}$  = random error

Hypothesis tested:

$$H_1 : A_I = 0 \text{ for all } I$$

$$H_2 : B_J = 0 \text{ for all } J$$

$$H_3 : C_K = 0 \text{ for all } K$$

$$H_4 : D_L = 0 \text{ for all } L$$

$$H_5 : AB_{IJ} = 0 \text{ for all } I \text{ and } J$$

Similarly for the interactions  $BC_{jk}, CD_{KL}, \text{ etc.}$

Consideration was given to confounding the  $3^2 2^2$  design. Since we are limited to two observations per cell, we have, altogether only seventy-two (72) observations. Confounding would introduce unwarranted complications and would be counterproductive. Confounding was thus avoided.

The results of the analysis of variance are shown in Figures 9 through 12. The results indicate that for the output of batteries #1 and #2, the only significant difference exists in the interaction between factors C (% overcharge) and D (battery condition;  $F_{.95(9,40)} = 2.83$ ). While for the efficiency, defined as per cent output divided by input in ampere-hours, times 100, of batteries #1 and #2 the interaction between factors C and D was significant and the main effect C was overwhelmingly significant.

For the output of batteries #3 and #4, significant differences existed in the main effect D, main effect C, and the interaction between effects C and D;  $F_{.95(9,40)} = 2.83$ . For the efficiencies of batteries #3 and #4, main effect C (% overcharge) and the interaction between effects B (charge rate), C (% overcharge) and D (battery type) showed significant differences at the 95% level.

Though the F test performed above may reject the null hypothesis that the means are equal, it does not tell us which means are significantly different from which. Scheffe' proposed a system of procedure for this problem which we shall employ.

### 3. SCHEFFE METHOD FOR MULTIPLE COMPARISON OF MEANS.

Suppose that we have estimates  $\bar{x}_i$  of true means  $\xi_i$ , with variances  $s^2/n_i$ ,  $s^2$  being estimated with  $f$  degrees of freedom. We are interested in contrasts, defined as

$$\theta = \sum_{i=1}^k c_i \xi_i, \quad (3.1)$$

where  $\sum_{i=1}^k c_i = 0$ . The contrast  $\theta$  is estimated as

$$H = \sum_{i=1}^k c_i \bar{x}_i, \quad (3.2)$$

with variance

$$V[H] = \sum_{i=1}^k c_i^2 \frac{\sigma^2}{n_i}.$$

The estimated variance of H is

$$\hat{V}[H] = \sum_{i=1}^k c_i^2 \frac{s^2}{n_i} = s^2 \sum_{i=1}^k \frac{c_i^2}{n_i}. \quad (3.3)$$

Scheffe's result is that we can construct  $(1 - \alpha)$  confidence limits for all possible contrasts  $\theta$ ,

$$P_r\{H - s\sqrt{\hat{V}[H]} < \theta < H + s\sqrt{\hat{V}[H]}\} = 1 - \alpha \quad (3.4)$$

where

$$s^2 = (k - 1)F_{1-\alpha}(k-1, f) \quad (3.5)$$

If for each experiment we perform, we construct confidence limits according to (3.4), then, in a fraction  $(1 - \alpha)$  of these experiments, all the confidence statements will be correct; in a fraction  $\alpha$ , one or more of the statements will be incorrect. The Scheffe method, furthermore, allows for comparisons of means when the number of observations,  $n_i$ , for the means are different.

Example: Let us suppose the following means are obtained:  $x_1 = 24$ ;  $x_2 = 22$ ;  $x_3 = 21$ ;  $x_4 = 17$ ;  $x_5 = 16$  and  $n = 4$  replications;  $k = 5$  treatments,  $s^2 = 4.50$  and number of degrees of freedom = 12. Suppose we wish to test the contrasts  $x_1, x_2, x_3$  versus  $x_4, x_5$ . Therefore;

$$H = \sum c_i \bar{x}_i = 2x_1 + 2x_2 + 2x_3 - 3x_4 - 3x_5 = 35 \quad (\sum c_i = 0)$$

and  $V(H) = (2^2 + 2^2 + 2^2 + (-3)^2 + (-3)^2) s^2/n = (30)(4.5)/4 = 33.75$  and therefore  $\sqrt{V(H)} = 5.81$ . To determine if a contrast is significant, we wish to know if  $|H|/\sqrt{V(H)} > S$  where  $S^2$  is described in equation 3.5. Since  $|H|/\sqrt{V(H)} = 6.02$  and  $S = \sqrt{(k-1)F_{.95}(4, 12)} = 3.61$ ;  $6.02 > 3.61$  and therefore the contrast is significant. The 95% confidence interval for the true value of the contrast,  $\theta$ , can be constructed using equation 3.4. For our example the 95% confidence interval for the true value of the contrast,  $\theta$ , will be  $14.03 < \theta < 55.97$ . Thus the difference between  $x_1, x_2, x_3$  and  $x_4, x_5$  will lie between the interval just calculated, at 95% confidence.

Figures 13 through 16 show the means,  $\bar{x}$ , standard deviations,  $\sigma$ , and the number of observations,  $N$ , of the different levels for both the output and efficiency of batteries #1 through #4. These means are employed in the Scheffe method to evaluate the estimate,  $H$ , of the contrast and construct the 95% confidence limits for several contrasts. The results of the Scheffe method are given in Figure 17 and 18 for batteries #1 and #2 and batteries #3 and #4, respectively. Batteries #1 and #2 were manufactured by General Electric and batteries #3 and #4 were manufactured by Sonotone Inc. The asterisked contrasts,  $H$ , in Figures 17 and 18 indicated significant differences at 95%; also, the 95% confidence limits for the contrasts are given.

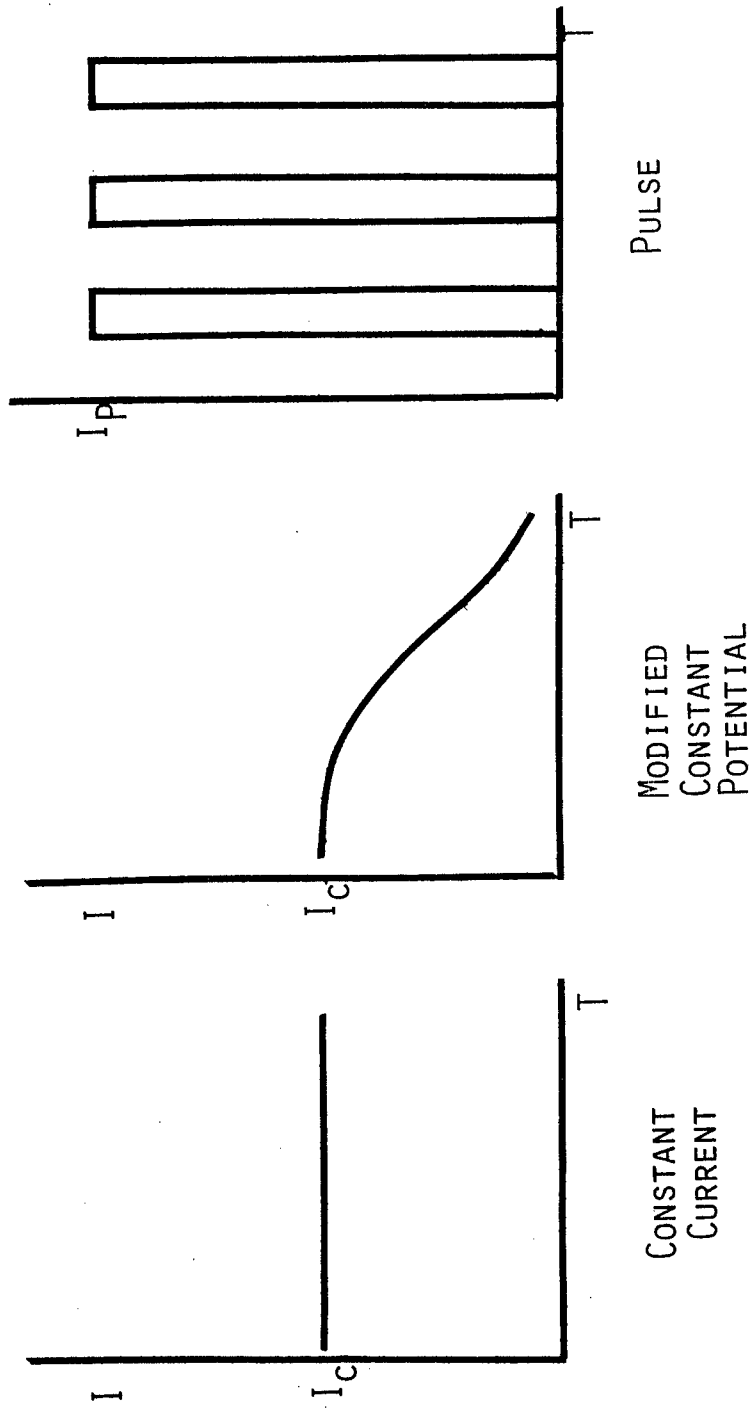
4. CONCLUSIONS. For batteries #1 and #2 (General Electric), the Scheffe results, Figure 17, indicate slight difference, on the average, in output between combinations of contrasts; however, a significant difference exists in the efficiencies as evidenced, in particular, in contrasts 1 and 2. Thus, analyzing the Scheffe results, one can infer that for pulse charging the use of 40% overcharge does not significantly increase battery output but is significantly less efficient than 20% overcharging and thus indicating large charge current losses through conversion of charge energy into heat. No significant effect of factor A (pulse amplitude) or factor B (charge current) is noticed on battery output or efficiency.

For batteries #3 and #4 (Sonotone), the Scheffe results for pulse charging, Figure 18, indicate a significantly higher average output at 40% overcharge than at 20% for identical contrasts as for the General Electric batteries, but still the 40% overcharge was significantly less efficient than 20% overcharge. Also, the new Sonotone battery had a better charge acceptance and therefore greater output than the old battery (contrasts 3,4,5 and 6); yet, the old battery had an average output of 40.70 ampere-hours (Figure 15, level  $d_1$ ). Again, factor A (pulse amplitude) and factor B (charge current) had no significant effect on battery output or efficiency.

In comparison, for the General Electric batteries the grand mean for the output was 38.16 ampere-hours and the efficiency was 76.37%, while for the Sonotone batteries the grand mean for the output was 42.04 ampere-hours and the efficiency was 74.67%. (The nominal rating of these batteries is 34.0 ampere-hours).

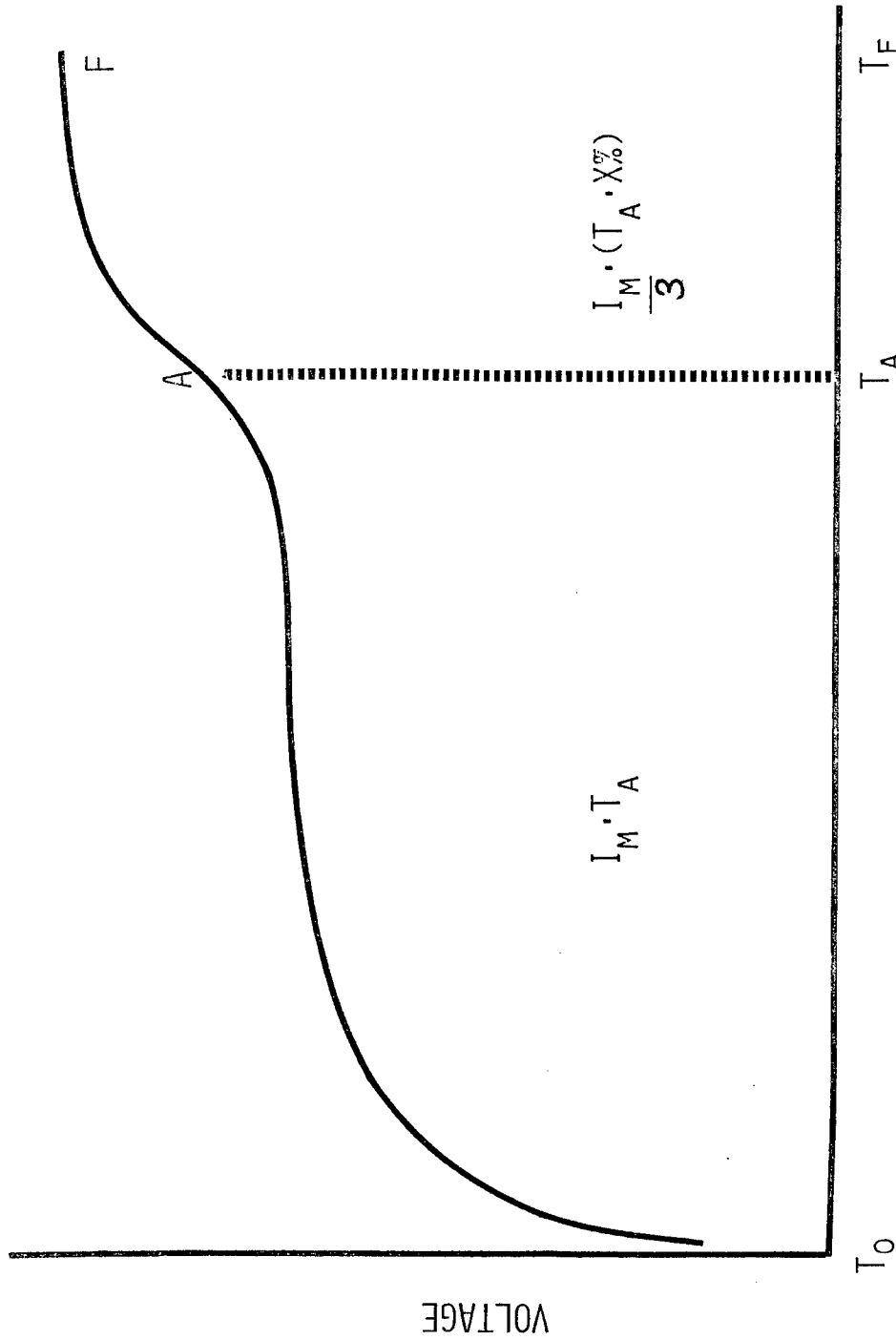
In summary, for pulse charging, the General Electric batteries, on the average, provided 12.2% greater output than its rating, while the Sonotone provided 23.6% greater output. No noticeable battery output degradation was observed as each battery underwent 36 random pulse charge - discharge cycles (Figures 5 and 7). Based on the F test, the Scheffe results, design practicality, the need for a quick battery recharge time, and from the standpoint of energy conservation, the optimum pulse charging levels would be 100 amperes peak pulse, 34 amperes main/11.3 amperes overcharge current at a 20% overcharge rate.

Future tests should be conducted to determine individual recharging effects of these optimum pulse charging levels on BB-433 batteries after they have undergone the present field service recharge conditions (constant current, etc.).



TYPICAL CHARGING METHODS

FIGURE 1



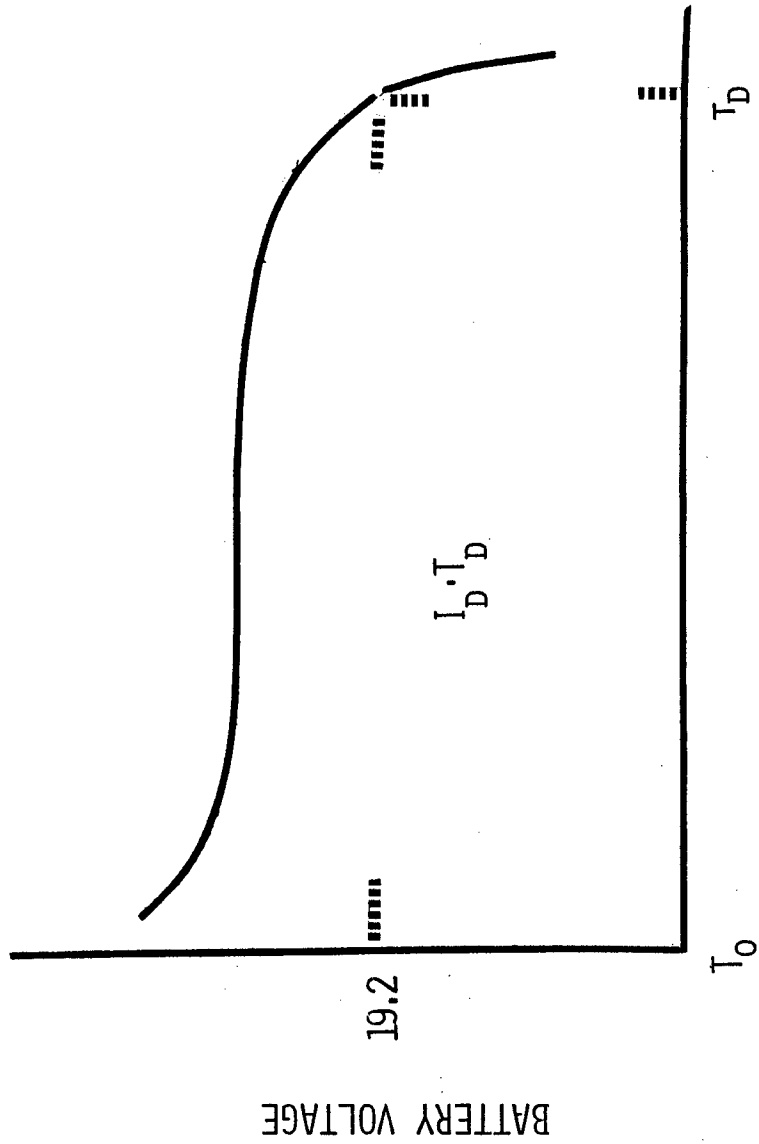
NICKEL-CADMIUM BATTERY CHARGE CHARACTERISTIC

$$\text{INPUT} = I_M \cdot T_A + \frac{I_M \cdot (T_A \cdot X\%)}{3}$$

(AMPERE-HOURS)

WHERE:  $I_M$  = MAIN CHARGE CURRENT  
 $T_A$  = TIME OF MAIN CHARGE  
 $X\%$  = PER CENT TOPPING

FIGURE 2



NICKEL-CADMIIUM BATTERY DISCHARGE CHARACTERISTIC

WHERE: I<sub>D</sub> = DISCHARGE CURRENT ( 17 AMPS )

T<sub>D</sub> = TIME TO 19.2 VOLTS

$$\text{OUTPUT} = I_D \cdot T_D$$

FIGURE 3



Factors and Levels of  
Pulse Charging Experiment

<u>A = Peak Pulse</u>	<u>B = Charge Current (Amps) *</u>
$a_0 = 100$ Amperes	$b_0 = 17/5.7$
$a_1 = 150$ Amperes	$b_1 = 25.5/8.5$
$a_2 = 200$ Amperes	$b_2 = 34/11.3$

<u>C = % Topping</u>	<u>D = Battery Type</u>
$c_0 = 20\%$	$d_0 = \text{New}$
$c_1 = 40\%$	$d_1 = \text{Used}$

\* The charge current is divided into main/overcharge current, e.g.,  $b_0 = 17/5.7$  indicates 17 amperes main charge and 5.7 amperes overcharge current

FIGURE 4

	d <sub>0</sub>						d <sub>1</sub>					
	c <sub>0</sub>			c <sub>1</sub>			c <sub>0</sub>			c <sub>1</sub>		
	b <sub>0</sub>	b <sub>1</sub>	b <sub>2</sub>	b <sub>0</sub>	b <sub>1</sub>	b <sub>2</sub>	b <sub>0</sub>	b <sub>1</sub>	b <sub>2</sub>	b <sub>0</sub>	b <sub>1</sub>	b <sub>2</sub>
a <sub>0</sub>	36.55	36.27	38.53	53.83	60.07	37.97	38.53	41.65	39.95	39.67	37.12	40.80
	35.70	35.70	36.55	35.55	37.40	36.27	37.12	36.55	38.53	38.82	37.40	37.40
a <sub>1</sub>	36.83	35.42	36.27	36.55	35.13	37.12	55.25	38.53	39.10	40.80	41.65	39.10
	36.55	35.98	36.55	36.27	36.27	36.27	37.12	36.83	37.40	35.70	37.68	36.83
a <sub>2</sub>	34.28	34.00	35.98	36.27	36.27	41.93	38.82	41.37	39.67	35.98	37.97	38.25
	35.42	33.15	36.27	37.12	36.55	36.27	39.67	39.67	38.82	36.55	36.83	36.83

Output Table

FACTORS:

A: Peak Pulse

a<sub>0</sub>: 100 amps

a<sub>1</sub>: 150 amps

a<sub>2</sub>: 200 amps

B: Charge Current

b<sub>0</sub>: 17/5.7 amps

b<sub>1</sub>: 25.5/8.5 amps

b<sub>2</sub>: 34/11.3 amps

C: % Topping Charge

c<sub>0</sub>: 20%

c<sub>1</sub>: 40%

D: Battery Type

d<sub>0</sub>: New (#1)

d<sub>1</sub>: Used (#2)

FIGURE 5

	$d_0$						$d_1$					
	$c_0$			$c_1$			$c_0$			$c_1$		
	$b_0$	$b_1$	$b_2$	$b_0$	$b_1$	$b_2$	$b_0$	$b_1$	$b_2$	$b_0$	$b_1$	$b_2$
$a_0$	89.50	88.92	91.52	92.05	85.84	59.89	87.09	88.82	88.54	56.26	65.02	61.95
	83.92	86.61	91.74	67.82	66.83	69.95	89.04	86.28	86.47	64.32	62.41	66.73
$a_1$	87.73	86.81	86.54	68.86	60.93	65.79	126.49	86.06	87.39	58.19	54.04	60.77
	88.97	84.94	88.01	63.89	65.53	63.64	85.73	87.23	86.14	64.17	67.00	67.06
$a_2$	81.12	85.74	91.18	65.20	61.69	50.73	87.20	90.13	85.42	62.03	68.55	64.15
	85.74	79.33	86.15	68.06	66.38	69.88	93.25	89.47	87.49	64.17	65.81	65.93

Efficiency Table

FACTORS:

A: Peak Pulse                      B: Charge Current                      C: % Topping Charge                      D: Battery Type  
 $a_0$ : 100 amps                       $b_0$ : 17/5.7 amps                       $c_0$ : 20%                       $d_0$ : new (#1)  
 $a_1$ : 150 amps                       $b_1$ : 25.5/8.5 amps                       $c_1$ : 40%                       $d_1$ : used (#2)  
 $a_2$ : 200 amps                       $b_2$ : 34/11.3 amps                       $c_2$ : 40%

FIGURE 6

	d <sub>0</sub>						d <sub>1</sub>					
	c <sub>0</sub>			c <sub>1</sub>			c <sub>0</sub>			c <sub>1</sub>		
	b <sub>0</sub>	b <sub>1</sub>	b <sub>2</sub>	b <sub>0</sub>	b <sub>1</sub>	b <sub>2</sub>	b <sub>0</sub>	b <sub>1</sub>	b <sub>2</sub>	b <sub>0</sub>	b <sub>1</sub>	b <sub>2</sub>
a <sub>0</sub>	42.78	43.07	43.15	43.07	47.88	45.62	33.28	58.08	36.44	52.72	41.06	44.91
	43.07	41.65	44.77	40.23	46.18	43.35	31.96	33.86	32.10	49.02	41.23	43.60
a <sub>1</sub>	41.08	45.05	41.08	44.48	43.92	44.77	34.13	35.70	33.98	46.17	47.60	48.88
	40.80	44.77	41.93	43.35	43.35	41.93	36.30	34.85	34.55	44.47	47.46	41.71
a <sub>2</sub>	44.20	43.63	45.05	44.20	50.15	44.20	38.29	37.83	34.93	53.66	41.51	40.58
	43.07	39.95	42.22	42.78	38.25	42.78	34.80	31.17	34.36	44.47	43.07	46.43

Output Table

FACTORS:

A: Peak Pulse      B: Charge Current      C: % Topping Charge      D: Battery Type  
 a<sub>0</sub>: 100 amps      b<sub>0</sub>: 17/5.7 amps      c<sub>0</sub>: 20%      d<sub>0</sub>: New (#3)  
 a<sub>1</sub>: 150 amps      b<sub>1</sub>: 25.5/8.5 amps      c<sub>1</sub>: 40%      d<sub>1</sub>: Used (#4)  
 a<sub>2</sub>: 200 amps      b<sub>2</sub>: 34/11.3 amps

FIGURE 7

	d <sub>0</sub>						d <sub>1</sub>					
	c <sub>0</sub>			c <sub>1</sub>			c <sub>0</sub>			c <sub>1</sub>		
	b <sub>0</sub>	b <sub>1</sub>	b <sub>2</sub>	b <sub>0</sub>	b <sub>1</sub>	b <sub>2</sub>	b <sub>0</sub>	b <sub>1</sub>	b <sub>2</sub>	b <sub>0</sub>	b <sub>1</sub>	b <sub>2</sub>
a <sub>0</sub>	81.80	88.08	84.38	65.86	59.18	61.82	82.58	56.10	78.53	56.97	64.95	66.24
	81.35	88.80	86.30	63.55	66.26	63.10	85.99	86.19	87.38	58.96	80.40	68.23
a <sub>1</sub>	81.83	84.52	88.34	60.85	68.63	69.74	62.02	81.75	84.22	62.59	62.50	60.36
	64.76	87.78	66.34	90.12	66.39	68.40	80.39	87.80	81.19	61.80	60.30	82.19
a <sub>2</sub>	72.21	87.26	87.48	91.51	58.59	64.34	78.44	81.64	84.36	56.50	92.98	71.92
	86.49	84.64	89.83	67.26	58.49	81.80	87.12	88.17	82.46	62.44	65.78	66.52

Efficiency Table

FACTORS:

A: Peak Pulse                      B: Charge Current                      C: % Topping Charge                      D: Battery Type

a<sub>0</sub>: 100 amps                              b<sub>0</sub>: 17/5.7 amps                              c<sub>0</sub>: 20%                              d<sub>0</sub>: New (#3)

a<sub>1</sub>: 150 amps                              b<sub>1</sub>: 25.5/8.5 amps                              c<sub>1</sub>: 40%                              d<sub>1</sub>: Used (#4)

a<sub>2</sub>: 200 amps                              b<sub>2</sub>: 34/11.3 amps

FIGURE 8

Analysis of Variance Table  
 (Batteries #1 and #2, Output)

SOURCE	D.F.	SS	MS	F RATIO
A	2	53.7245	26.8623	1.4902
B	2	5.5787	2.7894	0.1547
C	1	10.8190	10.8190	0.6002
D	1	35.9128	35.9128	1.9922
AxB	4	42.1819	10.5455	0.5850
AxC	2	64.5722	32.2861	1.7910
AxD	2	75.4045	37.7023	2.0915
BxC	2	15.8343	7.9172	0.4392
BxD	2	3.0390	1.5195	0.0843
CxD	1	103.4641	103.4641	5.7396
AxBxC	4	55.4999	13.8750	0.7497
AxBxD	4	61.6004	15.4201	0.8554
AxCxD	2	19.5804	9.7902	0.5431
BxCxD	2	22.2550	11.1275	0.6173
RESIDUAL	40	721.0592	18.0265	
TOTAL	71	1290.6059		

FIGURE 9

Analysis of Variance Table  
(Batteries #1 and #2, Efficiency)

SOURCE	D.F.	SS	MS	F RATIO
A	2	82.4559	41.2280	0.8143
B	2	82.3685	41.1843	0.8134
C	1	9595.5113	9595.5113	203.4924
D	1	5.911	5.9111	0.1254
AxB	4	115.6990	28.9248	0.6134
AxC	2	146.2396	73.1198	1.5507
AxD	2	266.2553	133.1277	2.8232
BxC	2	44.7423	22.3712	0.4744
BxD	2	0.3031	0.1516	0.0032
CxD	1	228.1604	228.1604	4.8386
AxBxC	4	183.2613	45.8153	0.9716
AxBxD	4	132.6138	33.1535	0.7031
AxCxD	2	48.8554	24.4277	0.5180
BxCxD	2	346.9326	173.4663	3.6787
RESIDUAL	40	1886.1666	47.1542	
TOTAL	71	13165.4762		

FIGURE 10

Analysis of Variance Table  
(Batteries #3 and #4, Output)

SOURCE	D.F.	SS	MS	F RATIO
A	2	12.4191	6.2096	0.3571
B	2	16.9933	8.4967	0.4880
C	1	501.2043	507.2643	29.1695
D	1	129.7392	129.7392	7.4605
AxB	4	51.1551	12.7899	0.7354
AxC	2	7.7669	3.8835	0.2233
AxD	2	3.5659	1.7830	0.1025
BxC	2	38.1900	19.0953	1.0982
BxD	2	25.1606	12.5803	0.7234
CxD	1	324.1483	324.1483	18.6397
AxBxC	4	41.3617	10.3404	0.5946
AxBxD	4	17.4804	4.3701	0.2513
AxCxD	2	9.5661	4.7831	0.2750
BxCxD	2	75.1227	37.0615	2.1772
RESIDUAL	40	695.6082	17.3902	
TOTAL	71	1956.1492		

FIGURE 11



Analysis of Variance Table  
(Batteries #3 and #4, Efficiency)

SOURCE	D.F.	SS	MS	F RATIO
A	2	197.5819	98.7940	1.2413
B	2	154.7335	77.3668	0.9721
C	1	3770.0139	3770.0139	47.3698
D	1	50.2002	50.2002	0.6308
AxB	4	20.9902	5.2476	0.0659
AxC	2	117.0239	58.5120	0.7352
AxD	2	1.8071	3.9036	0.0490
BxC	2	56.0922	28.0461	0.3524
BxD	2	168.7832	84.3916	1.0604
CxD	1	1.8688	1.8688	0.0235
AxBxC	4	341.4617	85.3654	1.0726
AxBxD	4	359.2192	89.8048	1.1284
AxCxD	2	162.7353	81.3676	1.0224
BxCxD	2	654.1355	327.0678	4.1096
RESIDUAL	40	3183.4776	79.5869	
TOTAL	71	9246.1302		

FIGURE 12

Mean Output Response  
 (Ampere - Hours)  
 (Batteries #1 and #2)

	$\bar{X}$	$\sigma$	Standard Error of $\bar{X}$	N
a <sub>0</sub>	39.33	5.73	1.17	24
a <sub>1</sub>	37.97	4.01	0.82	24
a <sub>2</sub>	37.25	2.02	0.45	24
b <sub>0</sub>	38.54	5.17	1.06	24
b <sub>1</sub>	38.14	5.15	1.05	24
b <sub>2</sub>	37.86	1.62	0.33	24
c <sub>0</sub>	37.79	3.57	0.60	36
c <sub>1</sub>	38.57	4.88	0.81	36
d <sub>0</sub>	37.48	5.04	0.84	36
d <sub>1</sub>	38.83	3.27	0.55	36

Grand mean = 38.16

FIGURE 13

Mean Efficiency (%) Response  
(Batteries #1 and #2)

	$\bar{X}$	$\sigma$	Standard Error of $\bar{X}$	N
$a_0$	78.23	12.58	2.57	24
$a_1$	16.15	16.11	3.29	24
$a_2$	75.62	12.28	2.51	24
$b_0$	78.37	16.04	3.27	24
$b_1$	76.26	11.98	2.45	24
$b_2$	75.96	12.96	2.65	24
$c_0$	88.41	7.07	1.18	36
$c_1$	65.32	7.22	1.20	36
$d_0$	77.15	11.99	2.00	36
$d_1$	76.58	15.24	2.54	36

Grand mean = 76.87

FIGURE 14

Mean Output Response  
 (Ampere - Hours)  
 (Batteries #3 and #4)

	$\bar{X}$	$\sigma$	Standard Error of $\bar{X}$	N
a <sub>0</sub>	42.63	6.19	1.26	24
a <sub>1</sub>	41.76	4.55	0.93	24
a <sub>2</sub>	41.73	5.05	1.03	24
b <sub>0</sub>	42.18	5.49	1.12	24
b <sub>1</sub>	42.55	5.79	1.18	24
b <sub>2</sub>	41.39	4.55	0.93	24
c <sub>0</sub>	39.39	5.48	0.91	36
c <sub>1</sub>	44.70	3.36	0.56	36
d <sub>0</sub>	43.38	2.20	0.37	36
d <sub>1</sub>	40.10	6.88	1.15	36

Grand mean = 42.04

FIGURE 15

Mean Efficiency (%) Response  
(Batteries #3 and #4)

	$\bar{X}$	$\sigma$	Standard Error of $\bar{X}$	N
a <sub>0</sub>	73.46	11.66	2.33	24
a <sub>1</sub>	73.53	10.87	2.22	24
a <sub>2</sub>	77.01	11.81	2.41	24
b <sub>0</sub>	72.77	11.64	2.38	24
b <sub>1</sub>	75.30	12.61	2.57	24
b <sub>2</sub>	74.69	13.09	2.67	24
c <sub>0</sub>	81.90	8.00	1.33	36
c <sub>1</sub>	67.43	9.61	1.60	36
d <sub>0</sub>	75.50	11.44	1.91	36
d <sub>1</sub>	73.83	11.49	1.91	36

Grand mean = 74.67

FIGURE 16

SCHEFFÉ RESULTS (GENERAL ELECTRIC, BATTERIES #1 and #2)

	OUTPUT						EFFICIENCY							
	$\bar{a}_0$	$\bar{a}_1$	$\bar{a}_2$	$\bar{b}_0$	$\bar{b}_1$	$\bar{b}_2$	$\bar{c}_0$	$\bar{c}_1$	$\bar{d}_0$	$\bar{d}_1$	H	Interval		
1.	1	0	-1	1	0	-1	1	-1	0	0	1.98	-6.86; 10.82	28.11*	19.27; 36.95
2.	1	0	-1	1	0	-1	-1	1	0	0	3.54	-5.30; 12.38	-18.07*	-26.91; -9.23
3.	1	0	-1	1	0	-1	1	-1	1	-1	0.63	-9.25; 10.51	28.68*	18.80; 38.56
4.	1	0	-1	1	0	-1	1	-1	-1	1	3.33	-6.52; 13.21	27.54*	17.66; 37.42
5.	1	0	-1	1	0	-1	-1	1	1	-1	2.19	-7.69; 12.07	5.02	-4.86; 14.90
6.	1	0	-1	1	0	-1	-1	1	-1	1	4.89	-4.99; 14.77	18.64*	-28.53; -8.75
7.	-1	0	1	1	0	-1	1	-1	0	0	-2.18	-11.02; 6.66	22.89*	14.05; 31.73
8.	-1	0	1	1	0	-1	-1	1	0	0	-0.62	-9.46; 8.22	-23.29*	-32.13; -14.45
9.	1	-1	0	1	0	-1	1	-1	0	0	1.25	-7.58; 10.10	26.98*	18.14; 35.82
10.	1	-1	0	1	0	-1	-1	1	0	0	2.82	-6.58; 11.66	-19.20*	-28.04; -10.36
11.	1	-1	0	1	-1	0	1	-1	0	0	0.98	-7.86; 9.82	26.68*	17.84; 35.52
12.	1	-1	0	1	-1	0	-1	1	0	0	2.54	-6.30; 11.38	-19.50*	-28.34; -10.66
13.	0	1	-1	0	1	-1	1	-1	0	0	0.22	-8.62; 9.06	24.52*	15.68; 33.36
14.	0	1	-1	0	1	-1	-1	1	0	0	1.78	-7.06; 10.62	-21.66*	-30.50; -12.82

\* Significant contrast

FIGURE 17

SCHEFFE RESULTS (SONOTONE, BATTERIES #3 and #4)

	OUTPUT						EFFICIENCY					
	$\bar{a}_0$	$\bar{a}_1$	$\bar{a}_2$	$\bar{b}_0$	$\bar{b}_1$	$\bar{b}_2$	$\bar{c}_0$	$\bar{c}_1$	H	Interval		
1.	1	0	-1	1	0	-1	1	-1	-3.62	-12.46; 5.22	9.00*	0.16; 17.67
2.	1	0	-1	1	0	-1	-1	1	7.00	-1.84; 15.84	-19.94*	-28.78; -11.10
3.	1	0	-1	1	0	-1	1	-1	-0.94	-10.82; 8.94	10.67*	0.79; 20.55
4.	1	0	-1	1	0	-1	1	-1	-6.30	-16.18; 3.58	7.33	-2.55; 17.21
5.	1	0	-1	1	0	-1	-1	1	9.68*	-0.20; 19.56	-18.27*	-28.17; -8.39
6.	1	0	-1	1	0	-1	-1	1	4.32	-5.56; 14.20	-21.61*	-31.49; -11.73
7.	-1	0	1	1	0	-1	1	-1	-5.42	-14.26; 3.42	16.10*	7.26; 24.94
8.	-1	0	1	1	0	-1	-1	1	5.20	-3.64; 14.04	-12.84*	-21.68; -3.99
9.	1	-1	0	1	0	-1	1	-1	-3.65	-12.49; 5.19	12.48*	3.64; 21.32
10.	1	-1	0	1	0	-1	-1	1	6.97	-1.87; 15.81	-16.46*	-25.30; -7.62
11.	1	-1	0	1	-1	0	1	-1	-4.81	-13.65; 4.03	11.87*	3.03; 20.71
12.	1	-1	0	1	-1	0	-1	1	5.81	-3.03; 14.65	-17.07*	-25.91; -8.23
13.	0	1	-1	0	1	-1	1	-1	-4.12	-12.96; 4.72	11.60*	2.76; 20.44
14.	0	1	-1	0	1	-1	-1	1	6.50	-2.34; 15.34	-17.34*	-26.18; -8.50

\* Significant contrast

FIGURE 18

## OPTICAL CHARACTERIZATION OF SURFACE ROUGHNESS

Eugene L. Church and John M. Zavada  
Pitman-Dunn Laboratory  
Frankford Arsenal  
Philadelphia, Pennsylvania

**ABSTRACT.** There is considerable Army interest in developing non-contact techniques for quantifying surface roughness. Here we consider light scattering as a tool for deducing statistical properties of surface microtopography with the aid of a suitable electromagnetic scattering formalism. For slightly rough surfaces the solution to the inverse scattering problem may be written in terms of the power spectrum of the surface roughness viewed through a window covering the nominal wavenumber range from the reciprocal wavelength of light on one extreme, to the reciprocal diameter of the probing beam on the other. As illustrations of the method we consider the characterization of two types of residual roughness on laser mirror surfaces: one-dimensional periodic roughness left by single-point diamond turning, and isotropic random roughness left by more conventional polishing techniques.

**1. INTRODUCTION.** The Army manufactures many high-quality optical components for laser and passive systems. The performance and usability of these components depends critically on their surface quality and structure. There is a need for quick and meaningful ways of testing these surfaces during manufacture and before use. Surface microroughness is a very important parameter in determining the quality of such surfaces; and this paper reviews the background and design of experiments to explore light scattering as a tool for measuring such surface microroughness.

Figure 1 indicates this need more fully. There are two principal methods of characterizing the residual microroughness of optical surfaces now in use: visual observation and stylus measurement. However, these methods have limitations as shown. What is needed is a method that is fast and objective, which can be used by unskilled personnel or automated, and which can measure roughnesses in the submicroinch range - down to 10 to 100 Å rms. Light scattering, as we will describe it, offers a possible means for doing this.

Figure 2 shows an artist's conception of how such a light-scattering device might work. It consists of a laser light source on the left, a photomultiplier detector on the right, and the sample under test in between. The laser light reflects and scatters from the sample, but a mask over the detector blocks out the specularly reflected light and only allows the scattered light to reach the sensitive area of the detector. The output of the detector goes to a meter. A good surface will scatter little light and give a low reading; a bad surface will give more scattering and a high reading. In principle, the meter reading can be related quantitatively to the roughness parameters of the surface, such as the surface variance.



Although it is easy to conceive of a device such as this, we do not know enough about the roughness characteristics of real surfaces at this time to make such a device meaningful or reliable.

The purpose of this paper is to describe the design of a series of experiments which we are setting up at Frankford Arsenal to generate the necessary data base on various types of real surfaces, to permit us to design and build and use light-scattering devices for surface test and evaluation.<sup>1</sup>

2. LIGHT SCATTERING. We have chosen light scattering as a technique because it provides a functional test of surface performance; it is an extremely sensitive way of measuring small deviations of an optical medium from its average behavior. The most familiar examples of this is Rayleigh scattering, which results from the scattering of sunlight from microparticles and density fluctuations in the atmosphere, and is responsible for the color of the blue sky and red sunset. The scattering we will consider today differs from simple Rayleigh scattering in two ways: first we consider the random deviations from a plane surface - a two-dimensional mirror - rather than a three-dimensional volume; and second, we include the possibility that the adjacent scattering centers are correlated with each other. In effect, then, we will be examining "opalescent-scattering" effects of the surface layer.<sup>2</sup>

Figure 3 sketches some of the underlying physics involved in the light-scattering process. Consider light incident on a sinusoidal, grating-like surface. In this case the scattered light is bunched into a series of discrete diffraction orders, whose angular positions are determined by the familiar grating equation shown, where  $\theta_i$  is the angle of incidence and  $\theta_s$  is the angle of scattering or diffraction. In the case of normal incidence,  $\theta_i = 0$ , and the grating equation reduces to the form shown on the second line, where the integer  $m = \pm 1, \pm 2$  ---- is the diffraction order.

The positions of the various diffracted orders is independent of the depth of the grating, but their intensities depend strongly on the depth. For a weak grating - one where the depth is much less than the wavelength of light, which is the case of interest here - only the two first-order diffraction lines ( $m = \pm 1$ ) appear with any significant intensity. They appear at the symmetric angles shown, and their intensities relative to the incident intensity - the grating efficiency  $\mathcal{E}$  - is shown below in the Figure.<sup>3</sup> Here  $k$  is the wavenumber of the incident light and  $\sigma^2$  is the variance of the surface roughness.

We now see the shape of things to come - there are two roughness length scales in the scattering problem: vertical and horizontal. The vertical roughness scale determines the intensity of the scattering, while the horizontal roughness scale determines its angular distribution.

Real surfaces are not simple sinusoidal gratings. However, we can generate realistic surfaces by making a Fourier superposition of elemental gratings such as considered here; by summing the scattering due to a large number of gratings with various wavelengths running in various directions over the two-dimensional surface. In the case where the rms depth of the grating is much less than the wavelength of light, the scattering of such a composite surface is simply proportional to the two-dimensional spectral density of the surface roughness. This is true whether the surface is described statistically or deterministically.<sup>3</sup>

Figure 4 sketches the notation we will use in describing an arbitrarily rough surface. The average surface is the x-y plane, and  $\zeta(x,y)$  is the deviation of the real surface from that average, with variance  $\sigma^2$ . The power spectrum,  $W$ , is the average square of the two-dimensional Fourier transform of  $\zeta$ , and is itself the two-dimensional transform of the surface autocorrelation function  $A$ . If the roughness is described as a stationary random function,  $A$  is then a function of the separation parameter,  $\rho$ . Specific examples of  $W$  and  $A$  are given in a later figure.

Figure 5 gives the form for the differential scattering intensity of a rough surface in terms of its power spectrum,  $W$ , for the illustrative case of unpolarized radiation normally incident on a perfect conductor.<sup>3</sup> The scattering intensity is proportional to  $k^4$  - which reflects its relationship to Rayleigh scattering. The factor  $1 + \cos^2 \theta$  is the polarization factor for electric-dipole scattering, which helps honey bees find their way home to the hive in the blue-sky version of this formula. The final factor is the two-dimensional power spectrum of the roughness, which contains all the information about the surface that is necessary to predict the scattering. It is a function of the two wavenumbers,  $p$  and  $q$ . However, for an isotropic surface  $W$  is a function only of the Pythagorean combination of the two wavenumbers  $p$  and  $q$ , which equals  $k \sin \theta$  - which is, in turn, the transverse momentum imparted to the scattered photons by the surface roughness.

The top formula in Figure 5 gives the differential scattering per unit solid angle. The total integrated scatter, or TIS, is the integral of this over the whole hemisphere. In the case where the scattering occurs principally at small angles,  $\theta$ , the TIS can be written in terms of the integral over  $W$  itself, which is just the surface variance,  $\sigma^2$ . In that case the TIS assumes the simple form given on the bottom of the Figure. This well-known formula is often used to estimate the variance of the surface roughness from measurements of the TIS, using an integrating light sphere. In the experiments we are considering, however, we will look at the differential light scattering intensity, which gives information about the form of  $W$  itself and not just its integral.

The expression for the TIS given on the bottom of Figure 5 has another significance in the present context - it is the expansion parameter used in the

perturbation theory which is used to derive the form for the scattering intensity given on the first line. In other words, the TIS must be  $\ll 1$  for this form to be valid. This is the mathematical definition of a slightly-rough or a weakly-rough surface as we use it here. In practice the TIS is of the order of 1% or less, which is one of the reasons we choose to look at the scattered light directly, rather than the corresponding reduction of the specular intensity.

The results shown here are a special case of a more general electromagnetic scattering formalism which was originally derived for radar scattering from the surface of the sea and various terrains. That general formalism includes the dependence of the scattering on the angle of incidence, the initial and final polarizations, and the complex dielectric response of the surface material. The only change that we need make in going from those radar results to our optics problem is to change the wavelength scale from meters to microns, and to use the appropriate optical-frequency dielectric response of the surfaces under study.<sup>4</sup>

3. PARTICULAR SURFACES. Figure 6 gives the power spectra for two idealized optical surfaces: a random, isotropically rough surface, and a deterministic, periodic surface. In the case of the randomly-rough surface we derive the form of  $W$  from the exponential autocorrelation function shown, where  $\ell$  is the transverse autocovariance length. This form is suggested by the Ornstein-Zernike analysis of critical opalescence.  $W$  is then the two-dimensional Lorentzian shown.

For the purpose of designing our experiments, this first form for  $W$  is taken to represent the surface generated by random polishing techniques. It predicts a continuous distribution of scattered intensity peaked about the specularly reflected beam. The longer the correlation length  $\ell$ , the sharper the peaking; until finally, when  $\ell$  becomes of the order of the size of the probing beam spot, the scattered light collapses into the diffraction cone of the specularly reflected beam. Conversely, the shorter the correlation length, the broader the scattering distribution, until in the limit where  $\ell \ll \lambda$ , the results go over into the simple Rayleigh scattering from a layer of independent scattering centers lying on the surface.

The second form of  $W$  shown is a deterministic form representing a periodic, a corrugated, surface; expanded in a Fourier series. The corresponding power spectrum is then a sum of products of various delta functions corresponding to the standing waves of the fundamental and harmonics that make up the corrugations. This type of roughness does not lead to a continuous scattering distribution, but rather, to a series of diffraction peaks - one peak for each harmonic - at the positions determined by the grating equation. In the special case of a single sine-wave component, these results reduce exactly to those of the simple grating already given in Figure 3. For the purpose of designing experiments, this second form of  $W$  is taken to represent the residual roughness on a surface generated by the single-point diamond turning.<sup>3</sup>

One important feature of slightly-rough scattering is illustrated by this second form for the power spectrum  $W$ : the scattering is insensitive to the signs and phases of the original Fourier decomposition. This means that even in the case of a deterministic surface, the most careful measurement of the scattered intensity will still not allow us to solve the inverse scattering problem exactly, and to reconstruct the parent surface uniquely. This is the price paid for exploring surface roughness with a light probe whose wavelength is much greater than the vertical scale of the roughness. Although the power spectrum does not tell us everything about the surface roughness, it does tell us all that we need to know to predict light scattering, and, therefore, it recommends itself as a natural quantity for characterizing the residual roughness of optical surfaces.

Now that we have defined forms of  $W$  corresponding to two types of optical surfaces of practical interest, the next step is to substitute these results into the previous expression for the scattered intensity and to evaluate the net result in cases of interest.

4. ILLUSTRATIVE RESULTS. Figure 7 illustrates typical results for a random surface with an exponential autocorrelation function. The rms roughness is taken to be 50 Å and the correlation length, 20 μm. These are typical values for polished metal mirrors.<sup>5,6</sup> The differential scattering intensity is plotted versus the scattering angle in degrees. There are two curves - one for the HeNe laser wavelength of 0.6328 μm, and one for the CO<sub>2</sub> laser wavelength of 10.6 μm. In this case of normal incidence the HeNe crosssection peaks at zero scattering angle, and falls off essentially as  $1/\theta^3$ . The CO<sub>2</sub> crosssection also peaks at 0° but is generally much smaller in magnitude because of its smaller wavenumber,  $k$ .

Figure 8 illustrates the corresponding results for a corrugated surface - the particular periodic surface shown in the upper corner. The half height is taken to be 87 Å to give the same TIS as the surface in the preceding slide; that is, about 1%. The period is 5 μm, which is typical for micromachined surfaces.<sup>7</sup>

The scattering here is in the form of a series of delta functions, each corresponding to a harmonic of the roughness:  $n = 1, 3, 5, 7$ . Only odd harmonics appear because of the vertical symmetry of the corrugations, and only the first four of these appear in scattering because  $n = 9$  and higher have wavelengths shorter than the HeNe laser, and do not diffract. Only HeNe results are given in this Figure since the CO<sub>2</sub> wavelength is 10.6 μm, which is already larger than the 5 μm fundamental, so that there is no diffraction at that wavelength and the surface appears perfectly smooth.

The intensity of the diffracted peaks falls off rapidly with increasing angle. This is not due to an inherent inefficiency of the diffraction process at large angles, but because the Fourier coefficients of the particular shape we have chosen fall rapidly with  $n$ . In particular, they go as  $1/n^2$ , so that the

diffraction intensity shown here falls off as  $1/n^4$ .

The results shown in Figures 7 and 8 have a double value; they can be used as a basis for designing specific experiments, and they illustrate the types of data that we hope to extract about real surfaces. To repeat, differential light scattering gives us information about the two-dimensional power spectrum of the residual roughness. These power spectra may be more complicated for real surfaces. However, for ease in comparison they are usually described by two length parameters -  $\sigma$  and  $\ell$ , in Figure 7, or  $h$  and  $d$  in Figure 8 - which represent the vertical and horizontal structure of the roughness.

As a final result, we consider the nominal ranges of these two length parameters that are spanned by the light-scattering experiments. These are shown in Figure 9. The shaded area is for the HeNe-wavelength laser and the dashed area for the  $\text{CO}_2$ . The squares represent - in effect - the windows through which light scattering allows us to view the surface roughness parameters; a kind of transfer function for the scattering process. The dot and the cross represent the two particular examples we considered before: the isotropically rough and periodic surfaces, respectively. As shown, they fall nicely in the HeNe window.

The limits of  $\sigma$  are determined from the intensity of the scattering; here, somewhat arbitrarily, by taking  $\text{TIS} = 10^{-4}$  and  $10^0$ . The limits on  $\ell$  are determined by angular considerations. A maximum scattering angle of  $90^\circ$  determines the minimum value of  $\ell = \lambda$ . A minimum angle of 10 milliradians, or  $\sim \frac{1}{2}^\circ$ , determines the maximum of  $\ell = 100\lambda$ . This minimum angle of  $\sim \frac{1}{2}^\circ$  is typical detector resolution for the experiments we have in mind. If we had a detector with infinitely good resolution, the upper limit for  $\ell$  would be limited by the diameter of the probing beam spot.

5. CONCLUSION. We are now setting up an experimental light-scattering facility at Frankford Arsenal based on the principles and results described above. This facility will be used to measure the scattering from a variety of real optical surfaces - metal mirrors and the metalized surfaces of transmissive optics - obtained from the Frankford Arsenal Optical Shops, industry, and other government laboratories. We plan to use the data generated by these experiments as a base for developing specific test and evaluation devices to satisfy the Army needs.

#### 6. REFERENCES AND FOOTNOTES.

1. Details are given in: The Design of Experiments for the Characterization of the Microroughness of Polished Surfaces by Light Scattering, E. L. Church and H. A. Jenkinson, Frankford Arsenal Report (to be published).
2. See, for example, L. Rosenfeld, Theory of Electrons, North Holland Publishing Company, 1951.

3. Paper presented at the Machining of Optics Workshop held at Boulder, Colorado, 22 May 1974 (proceedings to be published in Applied Optics): E. L. Church and J. M. Zavada, Characterization of the Residual Surface Roughness of Diamond-Turned Optics.
4. D. E. Barrick, Chapter 9 in Radar Cross Section Handbook, Plenum Press, 1970.
5. J. M. Bennett, private communication, 9 May 1974. See also the **proceedings** of the Workshop mentioned in ref. 3.
6. After the presentation of this paper we learned of the work of J. M. Eastman and P. W. Baumeister, J. Opt. Soc. Am. 64, 1369A and Opt. Comm. 12 418 (1974), which report measurements similar to those proposed here.
7. J. C. Stover and R. L. Gordon, private communications, May 1974. See also the proceedings of the Workshop mentioned in ref. 3.

BENCH CHARACTERIZATION OF THE  
RESIDUAL MICROROUGHNESS  
OF OPTICAL SURFACES

<u>METHOD</u>	<u>LIMITATIONS</u>	<u>DESIRED</u>
VISUAL	SLOW SUBJECTIVE/QUALITATIVE REQUIRES SKILLED PERSONNEL NOT ADAPTABLE	FAST  OBJECTIVE/ QUANTITATIVE
	SLOW LIMITED RANGE REQUIRES SKILLED PERSONNEL CONTACT/DESTRUCTIVE	UNSKILLED/ AUTOMATED  SUBMICROINCH (10-100 Å)

Figure 1. Methods of characterizing the residual roughness of optical surfaces

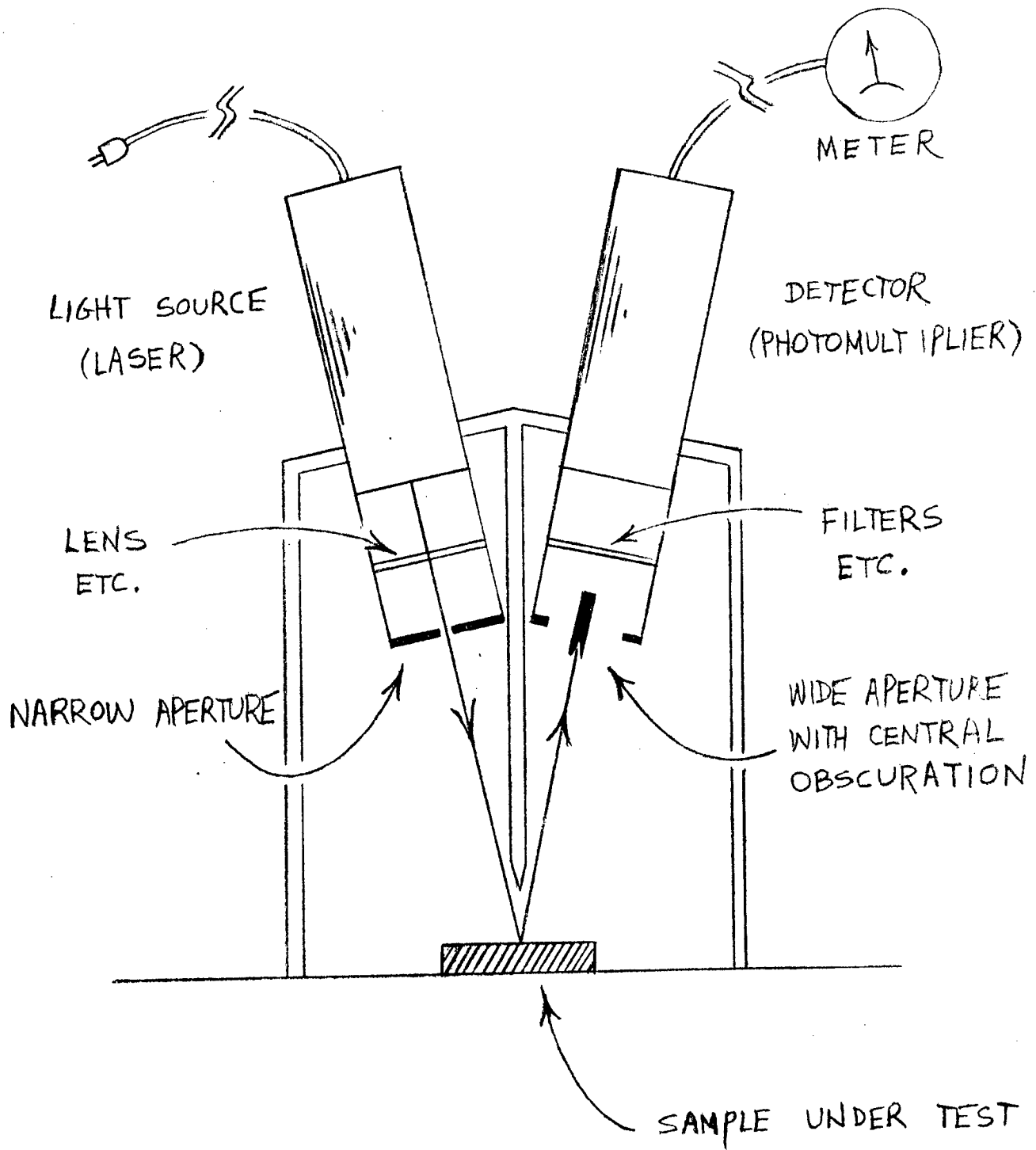
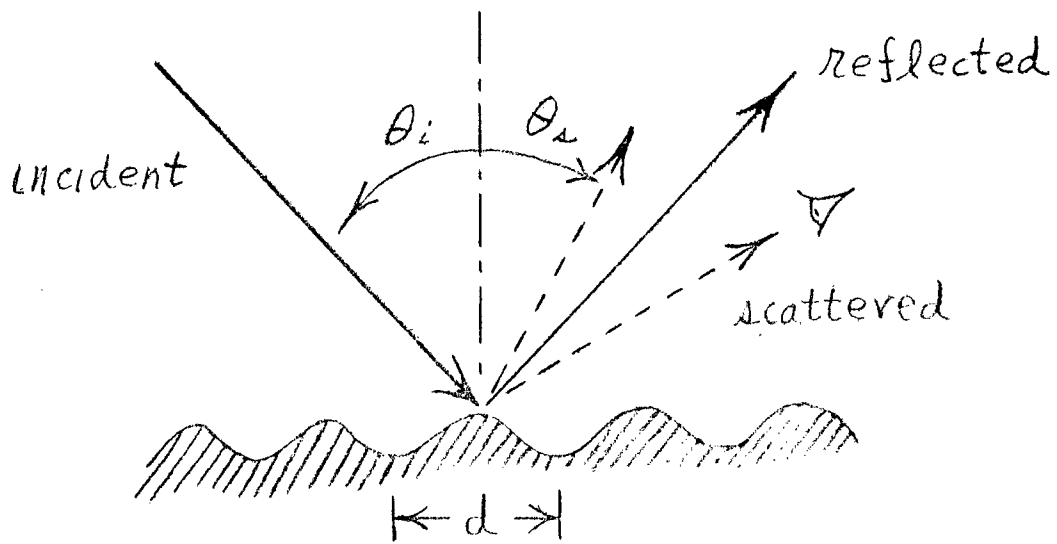


Figure 2. Schematic of possible scattering apparatus





Grating Equation:

$$\sin \theta_s = \sin \theta_i + m \frac{\lambda}{d}$$

Normal Incidence:

$$\sin \theta_s = m \frac{\lambda}{d} \quad ; \quad m = \pm 1, \pm 2, \dots$$

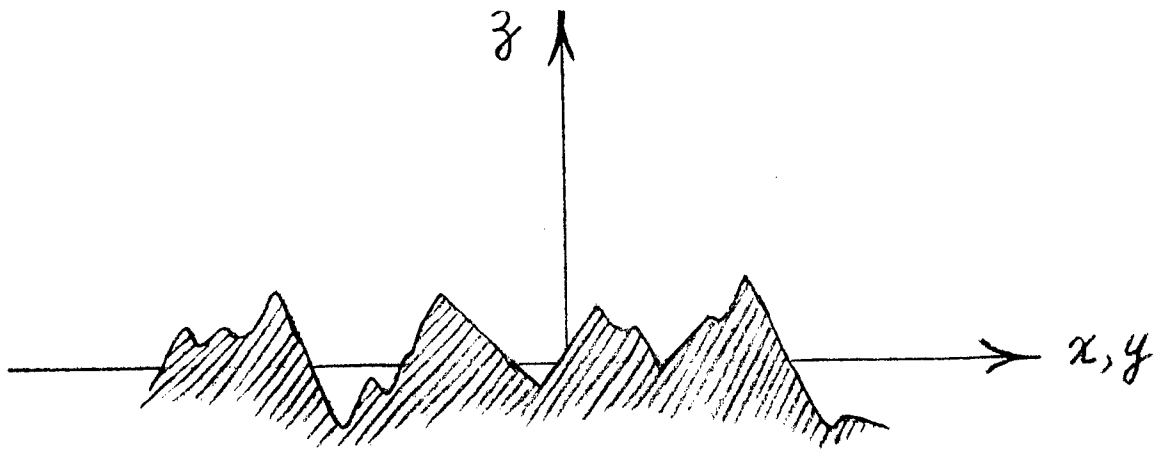
Weak Grating:

$$\sin \theta_s = \pm \frac{\lambda}{d}$$

$$\mathcal{C} = (k\sigma)^2 \left( \cos \theta_s + \frac{1}{\cos \theta_s} \right)$$

$$k = 2\pi/\lambda \quad ; \quad \sigma^2 = \text{variance}$$

Figure 3. Electromagnetic scattering from a sinusoidally rough surface



$$z = \zeta(x, y) ; \langle \zeta \rangle = 0 ; \langle \zeta^2 \rangle = \sigma^2$$

Power spectrum:

$$W(\rho, \theta) = \langle |\mathcal{F}^{(2)}\{\zeta(x, y)\}|^2 \rangle$$

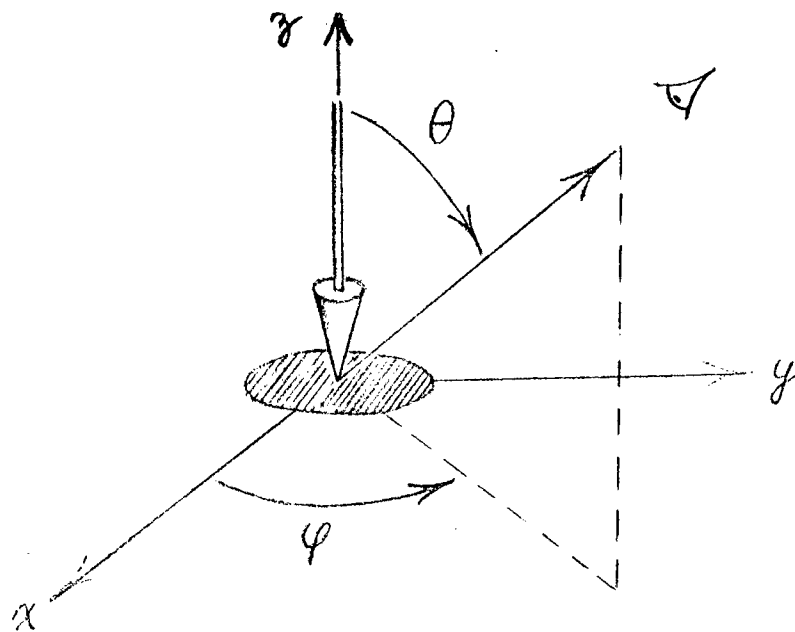
$$= \mathcal{F}^{(2)}\{A(\rho)\}$$

Autocovariance function:

$$A(\rho) = \langle \zeta(x, y)\zeta(x', y') \rangle$$

$$\rho = \sqrt{(x-x')^2 + (y-y')^2}$$

Figure 4. Notation describing an arbitrarily rough surface



$$\frac{dI}{d\Omega} = 2k^4 (1 + \cos^2 \theta) W(p, q)$$

$$p = k \sin \theta \cos \varphi$$

$$q = k \sin \theta \sin \varphi$$

$$r = \sqrt{p^2 + q^2} = k \sin \theta$$

Total Integrated Scatter:

$$TIS = \int \frac{dI}{d\Omega} d\Omega \approx 4k^2 \int dp \int dq W(p, q)$$

$$= 4k^2 \sigma^2 \ll 1$$

Figure 5. Electromagnetic scattering from an arbitrarily rough surface

### Isotropic Surface

$$A(\rho) = \sigma^2 e^{-\rho/l}$$

$$W(\rho, \rho) = \frac{1}{2\pi} \frac{\sigma^2 l^2}{[1 + (l\rho)^2]}^{3/2}$$

### Periodic Surface

$$\zeta(x, y) = \sum_{m=1} a_m \cos(2\pi m x/d + \varphi_m)$$

$$W(\rho, \rho) = \frac{1}{4} \sum_{m=1} a_m^2 \left[ \delta\left(\rho - \frac{2\pi m}{d}\right) + \delta\left(\rho + \frac{2\pi m}{d}\right) \right] \cdot \delta(\rho)$$

Figure 6. Expressions describing isotropic and periodic surface roughness

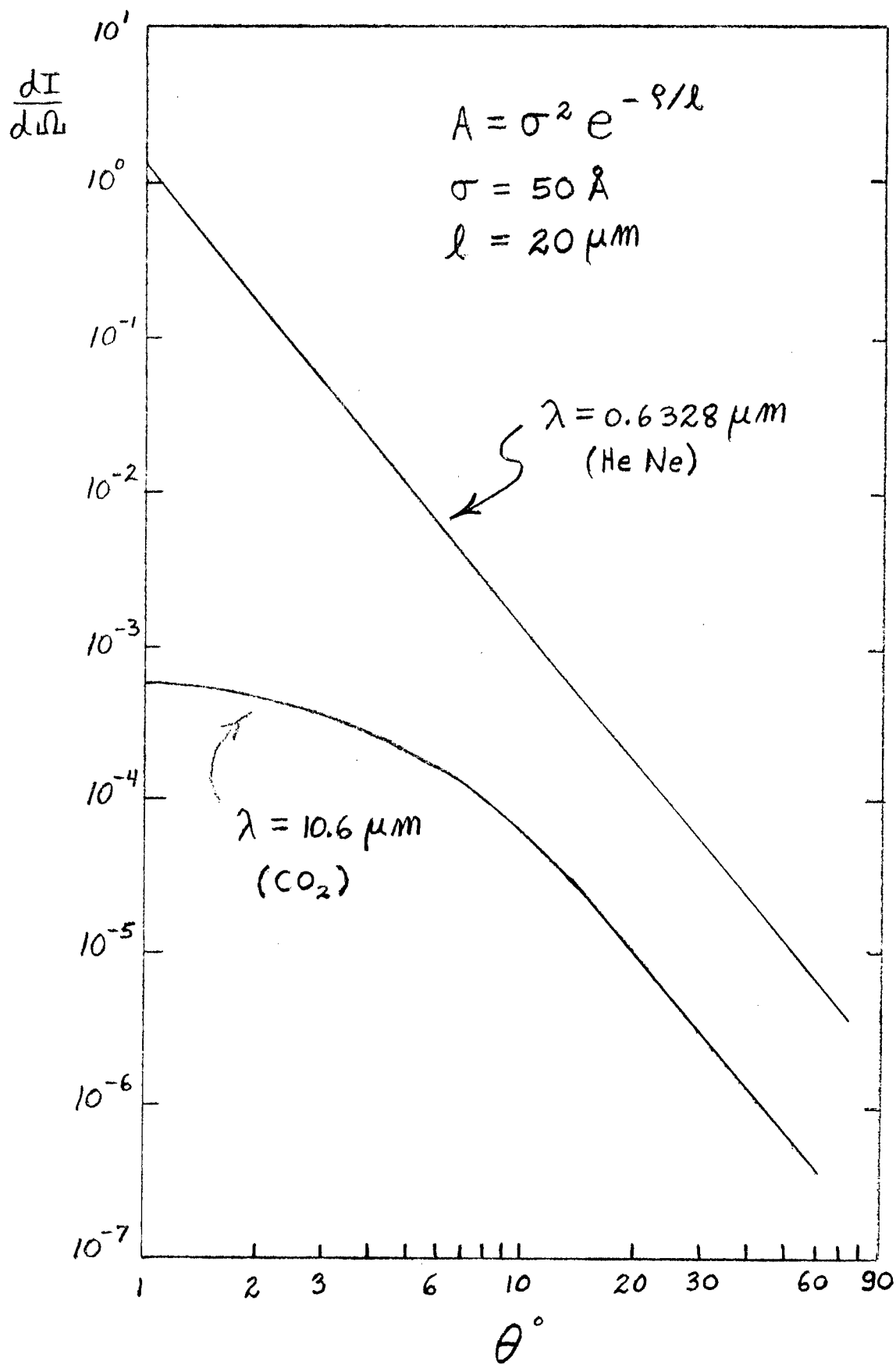


Figure 7. Predicted scattering crosssections for an isotropically rough surface

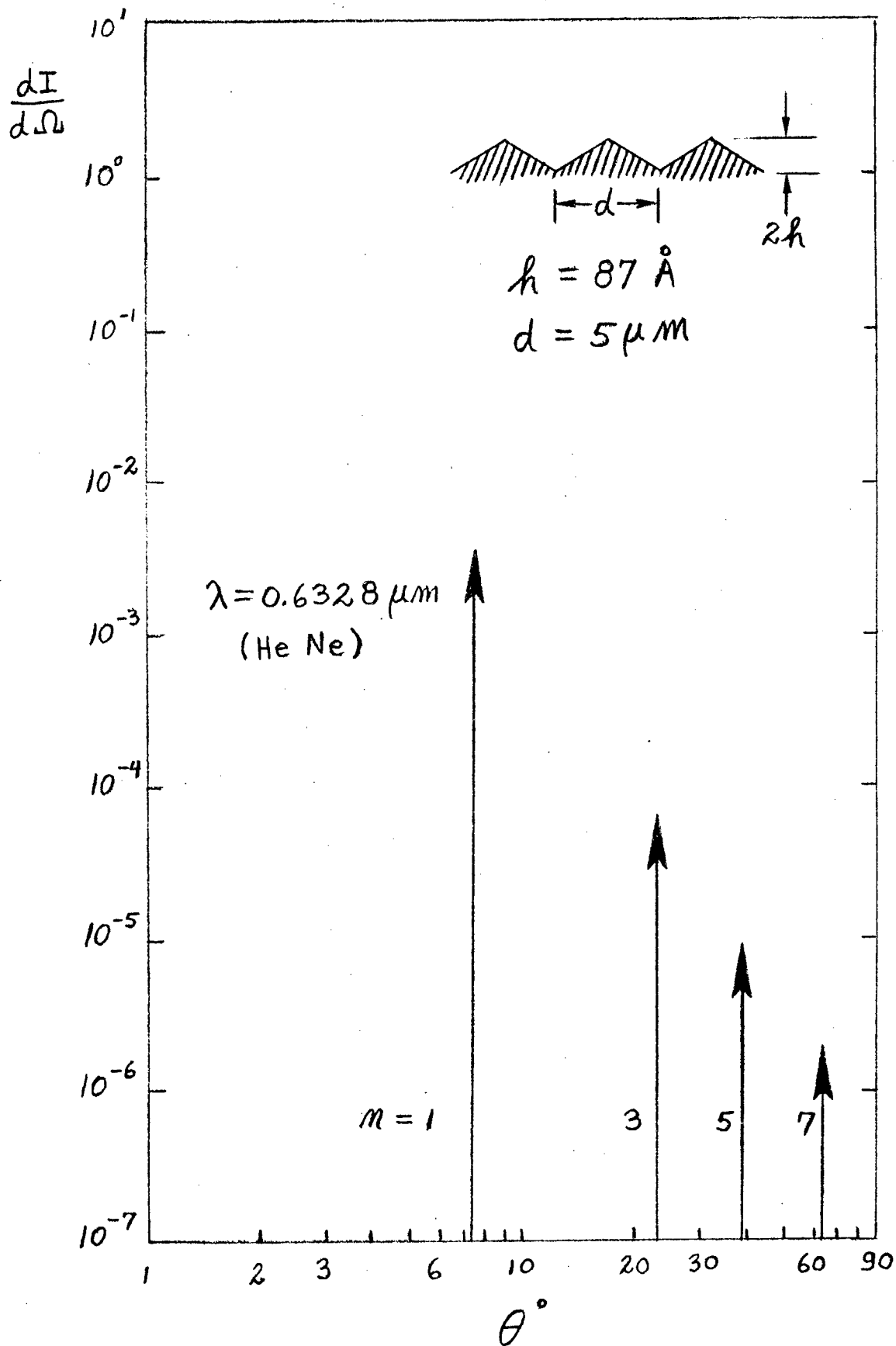


Figure 8. Predicted scattering cross section for a periodically rough surface

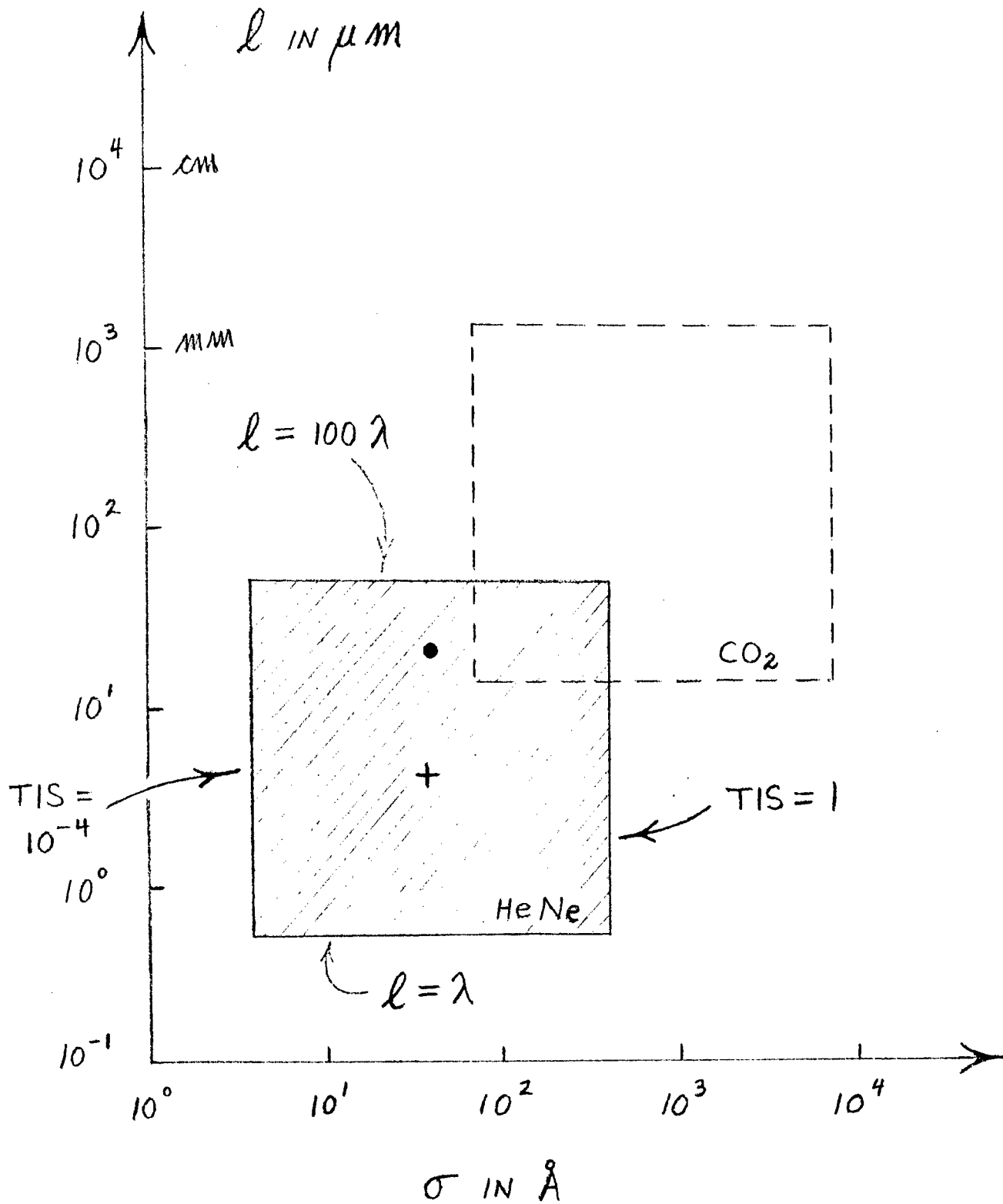


Figure 9. Ranges of surface parameters spanned by scattering experiments.

## RANKING AND SELECTION PROCEDURES\*

Robert E. Bechhofer  
Department of Operations Research  
Cornell University  
Ithaca, New York 14853

### 1. Introduction

In recent years statisticians have become increasingly concerned with the meaningful formulation and solution of certain multiple-decision problems which arise in experimentation. Thus, for example, when an experimenter conducts tests to compare the performances of several competing categories of items, his ultimate objective often is to select the category (or categories) which is (are) best, goodness being measured in terms of a particular parameter (e.g., the population mean or the population variance) associated with the random variable being observed. To accomplish this the experimenter requires a statistical decision procedure which will tell him how many observations to take, how to take these observations, and based on these observations which population(s) to choose; the decision procedure should have the property that the probability of an incorrect selection (or more generally, the risk or expected loss) is controlled at some specified level.

In response to the need for such decision procedures, research statisticians have been studying various possible appropriate formulations of these problems, and have developed a body of statistical methodology to cope with them. The procedures have come to be referred to as ranking and selection procedures. The purpose of this paper is to introduce the reader to these procedures, to describe some of them and the philosophy underlying their use, and to discuss their properties.

In Section 2 we will pose the normal means problem, and use it as a vehicle for motivating some of the basic ideas. The two most commonly adopted formulations of ranking and selection problems, namely the so-called indifference-zone approach and the subset approach, will be described. The attributes of single-stage, two-stage, and sequential procedures devised for the normal means problem, under different assumptions concerning the population variances, will be assessed. In Section 3 we sketch some analogous results for the normal variances problem, and in Section 4 we mention results for parameters of other distributions.

---

\* This research was supported in part by the U.S. Army Research Office-Durham under Contract DAHC04-73-C-0008 and by the Office of Naval Research under Contract N00014-67-A-0077-0020.



The number of research papers written on subjects in this field is now vast; it is hoped that this brief introduction will stimulate the reader to explore the literature, and to apply the procedures where appropriate.

## 2. The normal means problem

A very important problem which arises frequently in applications is that of selecting the normal population which has the largest population mean. Thus, for example, the ordnance engineer might be conducting firing programs to compare the ballistic performance of different types of projectiles (in which case his objective might be to select that type which, on the average, travels the greatest distance), or the medical research worker might be studying the response of patients to different kinds of analgesic drugs (in which case his interest might lie in selecting that drug which produces, on the average, the longest period of time without pain), or the agronomist might be conducting field trials with different varieties of grain (in which case his purpose might be to select that variety which produces, on the average, the largest yield per acre). In all of these cases large values of the means are deemed to be desirable; however, in other cases small values of the means might be considered desirable. The procedures that we will describe can, with minor modifications, handle these latter cases as well.

In Sections 2.1 and 2.3.1 we shall state the statistical assumptions which underlie the procedures that have been developed. Then we shall describe several approaches to the selection problem.

### 2.1 Statistical assumptions

We shall assume that we have  $k$  sources  $\Pi_i$  ( $1 \leq i \leq k$ ) of normally distributed data, the  $i$ th source having population mean  $\mu_i$  and population variance  $\sigma_i^2$ ; population  $\Pi_i$  ( $1 \leq i \leq k$ ) should be thought of as being associated with the  $i$ th category. The  $\mu_i$  are assumed to be unknown. Let  $\mu_{[1]} \leq \mu_{[2]} \leq \dots \leq \mu_{[k]}$  denote the ranked values of the  $\mu_i$ ; it is assumed that the pairing of the  $\Pi_i$  with the  $\mu_{[j]}$  ( $1 \leq i, j \leq k$ ) is completely unknown. Possible assumptions concerning the  $\sigma_i^2$  ( $1 \leq i \leq k$ ) will be discussed in Section 2.3.1. Throughout this paper  $X_{ij}$  ( $1 \leq i \leq k, j=1, 2, \dots$ ) will denote the  $j$ th observation from  $\Pi_i$ , all observations being assumed independent.

## 2.2 Some formulations

The two most commonly used formulations of the selection problem are due to Bechhofer [1954] and Gupta [1956], [1965]; these are referred to as the indifference-zone approach and the subset approach, respectively. The approaches are described below.

### 2.2.1 The indifference-zone approach

The goal and probability requirement associated with the indifference-zone approach are:

Goal: "To select the population associated with  $\mu_{[k]}$ ." (2.1)

It is assumed that prior to the start of experimentation the experimenter can specify two constants  $\{\delta^*, P^*\}$  ( $0 < \delta^* < \infty, 1/k < P^* < 1$ ) which are then incorporated into the following probability requirement:

Probability requirement:

Prob{Selecting the population associated with  $\mu_{[k]}$ }  $\geq P^*$  (2.2)  
whenever  $\mu_{[k]} - \mu_{[k-1]} \geq \delta^*$ .

The experimenter then restricts consideration to procedures which guarantee (2.2). (In (2.2) the specified quantity  $\delta^*$  can be thought of as the smallest difference "worth detecting" between the population mean of the "best" and "second best" population;  $P^*$  is specified strictly greater than  $1/k$  since a probability of  $1/k$  can be achieved by choosing one of the  $k$  populations at random.)

### 2.2.2 The subset approach

The goal and probability requirement associated with the subset approach are:

Goal: "To select a (non-empty) subset of the populations (2.3)  
which contains the population associated with  $\mu_{[k]}$ ."

It is assumed that prior to the start of experimentation the experimenter can specify a constant  $\{P^*\}$  ( $1/k < P^* < 1$ ) which is then incorporated into the following probability requirement:

Probability requirement:

$$\text{Prob}\{\text{Selected subset contains the population associated with } \mu_{[k]}\} \geq P^* \\ \text{regardless of the values of the } \mu_i \quad (1 \leq i \leq k). \quad (2.4)$$

The experimenter then restricts consideration to procedures which guarantee (2.4).

Remark 1: It is to be noted that the experimenter plans his experiment assuming that the population means are not all equal; this is a very reasonable assumption in almost all real-life situations. He is interested in identifying the "best" population -- in this case the population with the largest population mean. Goal (2.1) leads to a k-decision problem since the experimenter must choose one of the  $k$  populations based on the outcome of his experiment (i.e., his possible decisions are:  $\Pi_1$  is best, or  $\Pi_2$  is best, or ..., or  $\Pi_k$  is best). Similarly, goal (2.3) leads to a  $(2^k-1)$ -decision problem since the experimenter must choose one of the  $2^k-1$  non-empty subsets of the  $k$  populations based on the outcome of his experiment (e.g., for  $k=3$  his possible decisions are: only  $\Pi_1$  is in the subset, only  $\Pi_2$  is in the subset, only  $\Pi_3$  is in the subset,  $\Pi_1$  and  $\Pi_2$  are in the subset,  $\Pi_1$  and  $\Pi_3$  are in the subset,  $\Pi_2$  and  $\Pi_3$  are in the subset,  $\Pi_1$  and  $\Pi_2$  and  $\Pi_3$  are in the subset). These multi-decision approaches are in marked contrast to the classical 2-decision test-of-homogeneity approach afforded by the Analysis of Variance; in that approach the experimenter tests the (usually completely unrealistic) hypothesis that the  $k$  population means are equal, and decides based on the outcome of the experiment either to accept the hypothesis or to reject the hypothesis.

Remark 2: As noted above, goal (2.1) leads to a  $k$ -decision problem. However, depending on the practical situation under consideration, the experimenter can, using the indifference-zone approach, pose more general goals. For example, he may wish to select the  $t$  ( $1 \leq t \leq k-1$ ) best populations with regard to order, or he may wish to select the  $t$  ( $1 \leq t \leq k-1$ ) best populations without regard to order,  $t$  being fixed before the start of experimentation. (Both goals reduce to (2.1) when  $t=1$ .) These more general goals lead to a  $[k!/(k-t)!]$ -decision problem and a  $[k!/t!(k-t)!]$ -decision problem, respectively. Such general goals and others are discussed in Bechhofer [1954] and Mahamunulu [1967].

Remark 3: For goal (2.1) and the indifference-zone approach, the experimenter always ends up by selecting a single population. For goal (2.3) and the subset approach, the experimenter ends up by selecting 1 or 2 or ... or k populations, depending on the outcome of the experiment; thus for this latter approach the number of populations in the selected subset is a random variable.

### 2.2.3 Other approaches

Santner [1975] has proposed a restricted subset approach in which the experimenter selects 1 or 2 or ... or c populations, depending on the outcome of the experiment, where c ( $1 \leq c \leq k$ ) is decided on and fixed before the start of experimentation; his approach can be regarded as bridging the indifference-zone and subset approaches since if  $c=1$  his approach reduces to the indifference-zone approach while if  $c=k$  it reduces to the subset approach. Other approaches in which more general "loss functions" are used have been proposed by Somerville [1954] and Fairweather [1968]. An approach in which the  $\mu_i$  are assumed to have prior distributions has been considered by Dunnett [1960] while a similar idea from a Bayesian point of view has been proposed by Raiffa and Schlaiffer [1961] and Deely and Gupta [1968]. However, for brevity we will not discuss these or other approaches.

## 2.3 Assumptions concerning the variances

### 2.3.1 Possible assumptions

In order to devise procedures which will guarantee (2.2) or (2.4) for the normal means problem, it is necessary to make an assumption concerning the values of the  $\sigma_i^2$  ( $1 \leq i \leq k$ ). Which assumption it is appropriate for the experimenter to make in any particular practical situation depends on the information available to him at the time that he plans his experiment. The four most common assumptions are that:

a) The values of the  $\sigma_i^2$  ( $1 \leq i \leq k$ ) are known, and all are equal to  $\sigma^2$  (say). (2.5a)

b) The values of the  $\sigma_i^2$  ( $1 \leq i \leq k$ ) are known, but not all are equal. (2.5b)

c) The values of the  $\sigma_i^2$  ( $1 \leq i \leq k$ ) are unknown, but it is known that they have a common value  $\sigma^2$  (say). (2.5c)

d) The values of the  $\sigma_i^2$  ( $1 \leq i \leq k$ ) are completely unknown. (2.5d)

### 2.3.2 The variance assumption and associated procedures

Once the experimenter has adopted one of these assumptions he then must choose a selection procedure which was derived under that particular assumption.

Thus, for example, if he wishes to guarantee (2.2) and adopts assumption (2.5a) or (2.5b), then he can use a single-stage procedure (Bechhofer [1954]), a two-stage procedure (Alam [1970] or (Tamhane [1975])), an open sequential procedure without elimination (Bechhofer, Kiefer, Sobel [1968]), or a closed sequential procedure with elimination (Paulson [1964]). If he wishes to guarantee (2.2) and adopts assumption (2.5c), then he cannot use a single-stage procedure (see Dudewicz [1971]) although he can use a two-stage procedure (Bechhofer, Dunnett, Sobel [1954]) or a sequential procedure (Paulson [1964]); similarly, if he wishes to guarantee (2.2) and adopts assumption (2.5d), then he cannot use a single-stage procedure although he can use a two-stage procedure (Dudewicz and Dalal [1971] or Rinott [1974]). Finally, if the experimenter wishes to guarantee (2.4), and he adopts assumption (2.5a) or (2.5c), then he can use a single-stage procedure (Gupta [1956], [1965]).

When the experimenter has adopted a particular assumption and as a consequence has the option of choosing among several competing procedures, each one of which will guarantee his probability requirement, he then chooses one of these procedures on the basis of various possible operational or cost criteria. An indication of such criteria will be given in our later discussion. In the next section we shall describe certain selection procedures. Our emphasis will be on procedures which can be used with the indifference-zone approach to guarantee (2.2).

### 2.4 Procedures for use with the indifference-zone approach under the assumption of common known variance

In this section we shall describe three procedures, each one of which will guarantee (2.2) when assumption (2.5a) is made; minor modifications of these procedures will guarantee (2.2) when assumption (2.5b) is made. The procedures will be introduced in the order of their historical development, each being designed to afford different options to the experimenter.

### 2.4.1 Single-stage procedure

The easiest type of procedure to implement is a single-stage one. The following single-stage procedure was proposed by Bechhofer [1954]; constants  $c_{k,P^*}$  (see a), below) necessary to implement this procedure are given in Table I.

- "a) Take a common number  $N$  of observations from each of the  $k$  populations where  $N$  is the smallest integer greater than or equal to  $(c_{k,P^*}\sigma/\delta^*)^2$ .
- b) Calculate  $\bar{X}_i = \sum_{j=1}^N X_{ij}/N$  ( $1 \leq i \leq k$ ), and let  $\bar{X}_{[1]} < \bar{X}_{[2]} < \dots < \bar{X}_{[k]}$  denote the ranked values of the  $\bar{X}_i$ . (2.6)
- c) Select the population which yielded  $\bar{X}_{[k]}$  as the one associated with  $\mu_{[k]}$ ."

Note: The constants  $c_{k,P^*}$  are computed under the assumption that the  $\mu_i$  ( $1 \leq i \leq k$ ) are in the so-called least-favorable (LF) - configuration, i.e.,  $\mu_{[1]} = \mu_{[k-1]} = \mu_{[k]} - \delta^*$ .

Table I  
Values of  $c_{k,P^*}$

P*	k					
	2	3	4	5	7	10
0.99	3.2900	3.6173	3.7970	3.9196	4.0861	4.2456
0.95	2.3262	2.7101	2.9162	3.0552	3.2417	3.4182
0.90	1.8124	2.2302	2.4516	2.5997	2.7972	2.9829
0.80	1.1902	1.6524	1.8932	2.0528	2.2639	2.4608
0.60	0.3583	0.8852	1.1532	1.3287	1.5583	1.7700

The values in this table are abstracted from Table I of Bechhofer [1954] where values for other  $k$  and  $P^*$  are also given. Additional values for  $k = n+1 = 2(1)51$  and  $P^* = 0.99, 0.975, 0.95, 0.90, 0.75$  are contained in Table I of Gupta [1963]; Gupta's values must be multiplied by  $\sqrt{2}$  in order to obtain the  $c_{k,P^*}$  - values required in (2.6).

### 2.4.2 Open-ended sequential procedure without elimination

The single-stage procedure of Section 2.4.1 is conservative in the sense that the constants  $c_{k,P^*}$  necessary to implement it are computed under the assumption that the population means are in the LF-configuration; however, it has been shown (Hall [1959]) that the probability requirement (2.2) cannot be guaranteed with a smaller  $N$  if the experimenter restricts consideration to single-stage procedures. If this restriction is eliminated, and multistage procedures are permitted, then certain gains can be achieved. What is desired is a multi-stage procedure which not only will guarantee the probability requirement (2.2) when the population means are in the LF-configuration, but also will require a smaller number of observations per population, on the average, than the  $N$  of (2.6) when the population means are in very favorable configurations--in particular when  $(\mu_{[k]} - \mu_{[k-1]})/\sigma$  is large. The following sequential procedure, which possesses these attributes, was proposed by Bechhofer, Kiefer, and Sobel [1968], pp. 258-9, 264-7.

"a) Take one observation from each of the  $k$  populations at

each stage of experimentation. Let  $\sum_{j=1}^m X_{ij}$  denote the cumulative sum from  $\Pi_i$  ( $1 \leq i \leq k$ ) at the mth stage of experimentation, and let  $\sum_{j=1}^m X_{[1]j} < \sum_{j=1}^m X_{[2]j} < \dots < \sum_{j=1}^m X_{[k]j}$  denote the ranked values of the  $\sum_{j=1}^m X_{ij}$ .

b) At the  $m$ th stage of experimentation ( $m=1,2,\dots$ ) compute (2.7)

$$Z_m = \sum_{i=1}^{k-1} \exp \left\{ -\frac{\delta^*}{\sigma} \frac{\sum_{j=1}^m X_{[k]j} - \sum_{j=1}^m X_{[i]j}}{\sigma} \right\}.$$

Then proceed as follows:

i) If  $Z_m \leq (1-P^*)/P^*$ , stop experimentation and select the population which yielded  $\sum_{j=1}^m X_{[k]j}$  as the one associated with  $\mu_{[k]}$ .

ii) If  $Z_m > (1-P^*)/P^*$ , take another observation from each of the  $k$  populations and compute  $Z_{m+1}$ .

Continue in this manner until the rule calls for stopping."

Remark 4: For (2.7) the observations are taken in vectors, each vector constituting a stage, there being one observation from each population in every vector. The number of stages (i.e., number of observations per population) necessary to terminate experimentation is a random variable. The expected number of stages to terminate experimentation has been shown (B-K-S [1968], Tables 12.8.2 and 12.8.3) to be less than  $N$  for many configurations of the  $\mu_i$  ( $1 \leq i \leq k$ ); in particular, if  $(\mu_{[k]} - \mu_{[k-1]})/\sigma$  is large, then with high probability experimentation will cease after only a small number of stages. Regardless of the configuration of the  $\mu_i$  ( $1 \leq i \leq k$ ) experimentation will cease with probability one after a finite number of stages.

#### 2.4.3 Closed sequential procedure with elimination

The sequential procedure of Section 2.4.2 has two possible drawbacks:

i) It is opened, i.e., before the start of experimentation it is not possible to give a finite upper bound on the number of stages to terminate experimentation, and ii) It does not eliminate "non-contending" populations, i.e., it continues to sample from populations which, based on observations obtained in the early stages of experimentation, would appear to be out of contention for being selected as "best." The following sequential procedure, which overcomes these drawbacks of (2.7), was proposed by Paulson [1964]; like (2.7) it guarantees the probability requirement (2.2) when the population means are in the LF-configuration, and also tends to cease experimentation early when the population means are in very favorable configurations:

For fixed  $\lambda$  ( $0 < \lambda \leq \delta^*/2$ ) let  $a_\lambda = [\sigma^2/(\delta^* - \lambda)] \log[(k-1)/(1-P^*)]$ , and let  $W_\lambda =$  the largest integer less than  $a_\lambda/\lambda$ . Paulson's procedure is actually a family of procedures which depend on the choice of  $\lambda$ ; in Remark 9, below, we shall make some comments on the role of  $\lambda$ .

"Take one observation from each of the  $k$  populations at the first stage of experimentation. Eliminate from further consideration any population  $\Pi_i$  for which  $a_\lambda - \lambda < \max_{1 \leq s \leq k} X_{s1} - X_{i1}$ . If



all but one population is eliminated after the first stage, stop experimentation and select the remaining population as the one associated with  $\mu_{[k]}$ . Otherwise, go on to the second stage and take one observation from each population not yet eliminated. At stage  $m$  ( $2 \leq m \leq W_\lambda$ ) take one observation from each population not eliminated after the (m-1)st stage, and then eliminate from further consideration any remaining population  $\Pi_i$  for which

(2.8)

$$a_\lambda - m\lambda < \max_s \left\{ \sum_{j=1}^m X_{sj} \right\} - \sum_{j=1}^m X_{ij}$$

where the sums are only for populations left after the (m-1)st stage. If all but one population is eliminated after the mth stage, stop experimentation and select the remaining population as the one associated with  $\mu_{[k]}$ ; otherwise go on to the (m+1)st stage. If more than one population remains after stage  $W_\lambda$ , terminate experimentation at the  $(W_\lambda+1)$ st stage by selecting the remaining population with the largest sum of the  $(W_\lambda+1)$  observations as the one associated with  $\mu_{[k]}$ ."

Remark 5: The procedure (2.8) never requires more than  $W_\lambda+1$  stages to terminate experimentation.

Remark 6: The procedure (2.8) permanently eliminates apparently non-contending populations; thus the number of observations taken at the mth stage of experimentation is less than or equal to the number of observations taken at the (m-1)st stage of experimentation.

Remark 7: The cost of experimentation using procedures (2.7) and (2.8) can be measured in terms of expected number of stages to terminate experimentation and/or expected total number of observations to terminate experimentation. Which one is an appropriate measure will depend on the practical situation at hand.

Remark 8: Ramberg [1966] has demonstrated using Monte Carlo sampling methods that

$$\max_{\mu_1, \mu_2, \dots, \mu_k} E\{\text{Number of stages to terminate experimentation}\}$$

and

$$\max_{\mu_1, \mu_2, \dots, \mu_k} E\{\text{Total number of observations to terminate experimentation}\}$$

are less for (2.8) than for (2.7) when  $P^*$  is high (i.e., close to unity) but the inequality is reversed if  $P^*$  is sufficiently small; Perng [1969] has studied that question analytically. This result is of practical interest since it compares the performance of (2.7) and (2.8) when  $\mu_{[1]} = \mu_{[k]}$ , i.e., when, unknown to the experimenter, all of the population means are equal and thus the expected number of stages and the expected total number of observations are at their maxima.

Remark 9: Fabian [1974] pointed out the advantage of choosing  $\lambda = \delta^*/2$ , and recommended for that choice of  $\lambda$  that  $1-P^*$  in  $a_\lambda$  be replaced by  $2(1-P^*)$  yielding  $a'_{\delta^*/2} = [2\sigma^2/\delta^*]\log[(k-1)/2(1-P^*)] = b$  (say); then  $b$  replaces  $a_\lambda$  and  $\delta^*/2$  replaces  $\lambda$  in (2.8). This modified procedure still guarantees the probability requirement (2.2) when the population means are in the LF-configuration. It uniformly (in the  $\mu_i$ ) reduces the expected number of stages and expected total number of observations relative to the ones that would have been obtained with the unmodified procedure employing  $\lambda = \delta^*/2$ ; in addition, in either the family of unmodified Paulson procedures or in the family of modified Paulson procedures the choice  $\lambda = \delta^*/2$  has the property that

$$\max_{\mu_1, \mu_2, \dots, \mu_k} E\{\text{Total number of observations to terminate experimentation}\}$$

is approximately minimized for  $P^*$  close to unity.

#### 2.4.4 Two-stage procedure

The sequential procedures (2.7) and (2.8) have the drawbacks that they may not be appropriate for use in certain types of experimentation. For example, in agricultural experimentation where yields can be obtained only once per year (or per growing season), and thus only one vector of observations can be obtained per time period, multi-stage experimentation is impractical.

In such situations two-stage experimentation would appear to be appropriate. Alam [1970] and Tamhane [1975] have developed two-stage procedures which guarantee the probability requirement (2.2) when the population means are in the LF-configuration; their procedures screen out the apparently non-contending populations in the first stage, and concentrate sampling on the remaining populations in the second (terminal) stage. Tamhane's procedure has the added virtue of possessing a minimax property similar to that achieved by Fabian's modification of (2.8) when  $\lambda = \delta^*/2$ .

2.5 Procedures for use with the indifference-zone approach under the assumption of common unknown or completely unknown variances

As was mentioned in Section 2.3.2, if the experimenter wishes to guarantee (2.2) and adopts assumption (2.5c) or (2.5d) then he cannot use a single-stage procedure. In this section we shall consider two-stage procedures which accomplish these objectives.

2.5.1 Two-stage procedure for the common unknown variance case

The following two-stage procedure for the common unknown variance case was proposed by Bechhofer, Dunnett, and Sobel [1954]; constants  $h_{k,P^*,n}$  (see c), below) necessary to implement this procedure for  $P^* = 0.95$  are given in Table II.

"a) In the first stage take an arbitrary common number  $N_0 > 1$  of observations from each of the  $k$  populations.

b) Calculate  $S^2 = \sum_{i=1}^k \sum_{j=1}^{N_0} (X_{ij} - \sum_{j=1}^{N_0} X_{ij}/N_0)^2/n$  which is an unbiased estimate of  $\sigma^2$  based on  $n = k(N_0-1)$  degrees of freedom.

c) Enter the appropriate table (e.g., Table II, below, for  $P^* = 0.95$ ) with  $n = k(N_0-1)$  and the specified  $P^*$ , and obtain a constant  $h_{k,P^*,n} = h$  (say).

d) In the second stage, take a common number  $N-N_0$  of additional observations from each of the  $k$  populations where

$$N = N_0 \quad \text{if } 2(hS/\delta^*)^2 < N_0$$

$$N = [2(hS/\delta^*)^2] \quad \text{if } 2(hS/\delta^*)^2 > N_0,$$

(2.9)

and  $[y]$  denotes the smallest integer equal to or greater than  $y$ .

e) Calculate the  $k$  over-all (first-stage plus second stage) sample

sums  $\sum_{j=1}^N X_{ij}$  ( $1 \leq i \leq k$ ), and let  $\sum_{j=1}^N X_{[1]j} < \sum_{j=1}^N X_{[2]j} < \dots <$

$\sum_{j=1}^N X_{[k]j}$  denote the ranked values of the  $\sum_{j=1}^N X_{ij}$ .

f) Select the population which yielded  $\sum_{j=1}^N X_{[k]j}$  as the one associated with  $\mu_{[k]}$ .

Note: The constants  $h_{k,P^*,n}$  are computed under the assumption that the  $\mu_i$  ( $1 \leq i \leq k$ ) are in the LF-configuration.

Table II

Values of  $h_{k,P^*,n}$  for  $P^* = 0.95$

n	k					
	2	3	4	5	7	10
5	2.02	2.44	2.68	2.85	3.08	3.30
6	1.94	2.34	2.56	2.71	2.92	3.12
7	1.89	2.27	2.48	2.62	2.82	3.01
8	1.86	2.22	2.42	2.55	2.74	2.92
9	1.83	2.18	2.37	2.50	2.68	2.86
10	1.81	2.15	2.34	2.47	2.64	2.81
15	1.75	2.07	2.24	2.36	2.51	2.67
20	1.72	2.03	2.19	2.30	2.46	2.60
30	1.70	1.99	2.15	2.25	2.40	2.54
60	1.67	1.95	2.10	2.21	2.35	2.48
$\infty$	1.64	1.92	2.06	2.16	2.29	2.42

The values in this table are abstracted from Table 1a of Dunnett [1955]; Table 1b of Dunnett [1955] gives corresponding values for  $P^* = 0.99$ ; Dunnett's  $p$  equals our  $k-1$ .

Note: The value of  $h_{k,P^*,n}$  given for the  $n = \infty$  row of Dunnett [1955], Table 1a, is the same as the value given by Gupta [1963], Table I, for the same  $k-1 = p = n$  and  $P^* = 0.95 = 1-\alpha$ .

Remark 10: The total number of observations  $N$  required by the two-stage procedure is a random variable since its value depends on the value of  $S^2$ ; no additional observations are taken in the second stage if  $S^2$  is sufficiently small.

Remark 11: Paulson [1964], Section 5, proposed an open-ended sequential procedure which permanently eliminates non-contending populations; his procedure is applicable in situations in which the common variance is unknown.

#### 2.5.2 Two-stage procedures for the completely unknown variance case

Dudewicz and Dalal [1971], and also Rinott [1974], proposed two-stage procedures for the completely unknown variance case. Like (2.9), the common number of observations in the first stage for each of these procedures is arbitrary ( $>1$ ), while the total number of observations per population is a random variable.

#### 2.6 Procedure for use with the subset approach under the assumption of common (known or unknown) variance

As was mentioned in Section 2.3.2, if the experimenter wishes to guarantee (2.4) and adopts assumption 2.5a) or 2.5c), then he can use a single-stage procedure. The following single-stage procedure was proposed by Gupta [1956], [1965] for use under assumption 2.5c); constants  $d_{k,P^*,n}$  (see c), below) necessary to implement this procedure are given in Table III. (Under assumption 2.5a, the random variable  $S$  in d) of (2.10) is replaced by  $\sigma$ , and the value of  $d_{k,P^*,n}$  for  $n = \infty$  is used.)

a) Take a common arbitrary number  $N > 1$  of observations from each of the  $k$  populations.

b) Calculate  $\bar{X}_i = \sum_{j=1}^N X_{ij}/N$  ( $1 \leq i \leq k$ ) and let  $\bar{X}_{[1]} < \bar{X}_{[2]} < \dots < \bar{X}_{[k]}$

denote the ranked values of the  $\bar{X}_i$ ; also calculate

$$S^2 = \sum_{i=1}^k \sum_{j=1}^N (X_{ij} - \sum_{j=1}^N X_{ij}/N)^2/n$$

which is an unbiased estimate

of  $\sigma^2$  based on  $n = k(N-1)$  degrees of freedom.

(2.10)

c) Enter the appropriate table (e.g., Table III, below, for  $P^* = 0.95$ ) with  $n = k(N-1)$  and the specified  $P^*$ , and obtain a constant  $d_{k,P^*,n} = d$  (say).

d) Retain the population  $\Pi_i$  ( $1 \leq i \leq k$ ) in the selected subset if and only if  $\bar{X}_i \geq \bar{X}_{[k]} - dS/\sqrt{N}$ .

Table III

Values of  $d_{k,P^*,n}$  for  $P^* = 0.95$

n	k		
	2	5	10
15	2.48	3.34	3.78
20	2.44	3.25	3.67
30	2.40	3.19	3.59
60	2.36	3.12	3.50

The values in this table are abstracted from Table I of Gupta and Sobel [1957] which gives many additional  $d$ -values for  $P^* = 0.75, 0.90, 0.95, 0.975, 0.99$ .

Note:  $d_{k,P^*,n} = \sqrt{2} h_{k,P^*,n}$  where  $h_{k,P^*,n}$  is given in Table II.

Remark 12: The width of the "yardstick" in d) of (2.10) is  $dS/\sqrt{N}$  which decreases with  $N$ ; thus the larger the value of  $N$ , the smaller the expected number of populations that will be included in the selected subset. Also, for fixed  $N$

the more favorable the configuration of the population means (e.g., the larger the value of  $(\mu_{[k]} - \mu_{[k-1]})/\sigma$ ), the smaller the expected number of populations that will be included in the selected subset. (This expected number always lies between unity and  $kP^*$ .)

Remark 13: In practice the subset approach is often used for screening purposes, since it tends to eliminate "non-contending" populations (i.e., those with small  $\mu$ -values) from the selected subset. The populations retained in the subset can then be subjected to further study in an independent follow-up experiment in which the indifference-zone approach (say) is used.

### 2.7 Factorial experiments involving means

The statistical model given in Section 2.1 is appropriate for single-factor experiments. In a two-factor experiment we have  $rc$  normal populations  $\Pi_{ij}$  ( $1 \leq i \leq r, 1 \leq j \leq c$ ) with population means  $\mu_{ij}$  and population variances  $\sigma_{ij}^2$ . It is sometimes appropriate to assume that  $\mu_{ij} = \mu + \alpha_i + \beta_j$  ( $\sum_{i=1}^r \alpha_i = \sum_{j=1}^c \beta_j = 0$ ), i.e., that there is no interaction between the factors, and that  $\sigma_{ij}^2 = \sigma^2$  ( $1 \leq i \leq r, 1 \leq j \leq c$ ). Here the  $\alpha_i$  and the  $\beta_j$  are referred to as the "effects" of the first and second factor, respectively. It is assumed that  $\mu$ , the  $\alpha_i$ , the  $\beta_j$ , and  $\sigma^2$  are unknown. Let  $\alpha_{[1]} \leq \alpha_{[2]} \leq \dots \leq \alpha_{[r]}$  and  $\beta_{[1]} \leq \beta_{[2]} \leq \dots \leq \beta_{[c]}$  denote the ranked values of the  $\alpha_i$  and the  $\beta_j$ ; it is assumed that the pairing of the  $\Pi_{ij}$  with the  $\alpha_{[i]}$  and  $\beta_{[j]}$  ( $1 \leq i \leq r, 1 \leq j \leq c$ ) is completely unknown.

In the above setup it is possible to consider goals such as

Goal: "To select the 'level' of the first factor associated with  $\alpha_{[r]}$ , and simultaneously to select the 'level' of the second factor associated with  $\beta_{[c]}$ ," (2.11)

with associated probability requirements. Such problems are treated for the indifference-zone approach in Section 4 of Bechhofer [1954]. The virtue of conducting factorial experiments in this situation is discussed by Bawa [1972]. The indifference-zone selection procedures of Sections 2.4 and 2.5 can be used in multi-factor experiment; it is only necessary to make appropriate modifications in the procedures.

It is also possible to conduct single-factor or multi-factor ranking and selection experiments using the standard experimental designs such as randomized blocks and Latin squares, and these designs play the same type of role here as they do in classical hypothesis-testing situations.

### 2.8 Means vs. a fixed known standard

In Section 2.4.1-2.4.4 and 2.5.1-2.5.2 the selection procedures proposed were devised to select the category associated with the largest  $\mu$ -value. However, in certain classes of experiments even the "best" one of the competing categories, i.e., the category with the largest  $\mu$ -value, may not be good enough to warrant the experimenter's selecting it. For example, if the competing categories are drugs, the best one may not be worthy of consideration unless the expected period of immunity obtained with that drug is at least some specified period of time; or if the competing categories are types of heat treatment of steel, the best one may not be deemed satisfactory unless the expected tensile strength resulting from that type of treatment is at least some specified minimum value. Such types of problems involving comparisons of means with a fixed known standard are considered by Bechhofer and Turnbull [1974], [1975a]; in the first paper a single-stage procedure is proposed under assumption (2.5a), and in the second a two-stage procedure is proposed under assumption (2.5c). These procedures are generalizations of Bechhofer [1954] and Bechhofer, Dunnett, and Sobel [1954]. Gupta and Sobel [1958] proposed a single-stage procedure for this problem using the subset approach.

### 3. The normal variances problem

Section 2 dealt with the normal means problem. Corresponding procedures exist for the normal variances problem. Ranking and selection problems involving variances arise, for example, when the ordnance engineer is interested in selecting that type of projectile which yields the smallest dispersion of range, or when the laboratory technician is interested in selecting that measuring instrument which has the highest precision (e.g., that scale which has the greatest reproducibility). An analogue of the single-stage procedure given in Bechhofer [1954] for normal means is given in Bechhofer and Sobel [1954] for normal variances; factorial experiments involving variances are treated in Bechhofer [1968a] and [1968b] using a model proposed in Bechhofer [1960].



Bechhofer and Turnbull [1975b] is the counterpart for variances of Bechhofer and Turnbull [1974]. An analogue of the procedure given in Gupta [1956] for normal means is given in Gupta and Sobel [1962] for normal variances.

#### 4. The Bernoulli p problem, and other problems

Ranking and selection problems involving Bernoulli p's (i.e., probabilities of "success" on a single trial) arise, for example, when a consumer is interested in selecting that producer whose product has the smallest fraction defective. An analogue of the procedure given in Bechhofer [1954] for normal means is given in Huyett and Sobel [1957] for Bernoulli p's, while the counterpart of the procedure given in Gupta [1956] for normal means is given in Gupta and Sobel [1960] for Bernoulli p's.

Sobel [1954] proposed a sequential procedure for selecting the exponential population with the largest mean; his results have applicability in reliability studies. Bechhofer, Kiefer, and Sobel [1968], p. 63 considered sequential procedures for ranking parameters of certain stochastic processes such as the Poisson process and the Wiener process. Various research workers have proposed procedures for many other ranking and selection problems involving parameters of distributions arising in practice.

#### 5. Closing remarks

The ranking and selection formulation of statistical problems involving inferences concerning  $k \geq 2$  categories has wide applicability in the solution of problems arising in experimentation. In this paper we have sketched only a small number of the relevant ideas and procedures. The interested reader is referred to Bechhofer, Kiefer, and Sobel [1968] for references up to that date, and to Gupta and Panchapakesan [1972] for references to the latter date concerning the subset approach. Additional and more recent references are given by Wetherill and Ofosu [1974]. The writer would appreciate learning of experimental situations in which some of the procedures described herein have proved helpful.

#### 6. Acknowledgment

The writer would like to express his appreciation to the Army Research Office-Durham and the Office of Naval Research which have generously supported his research and that of his colleagues at Cornell who have been working with him on this program.

## 7. References

- Alam, K. (1970): "A two-sample procedure for selecting the population with the largest mean from  $k$  normal populations," Annals of the Institute of Statistical Mathematics (Tokyo), Vol. 22, pp. 127-136.
- Bawa, V. S. (1972): "Asymptotic efficiency of one R-factor experiment relative to R one-factor experiments for selecting the best normal population," Journal of the American Statistical Association, Vol. 67, No. 339, pp. 660-661.
- Bechhofer, R. E. (1954): "A single-sample multiple-decision procedure for ranking means of normal populations with known variances," Annals of Mathematical Statistics, Vol. 25, No. 1, pp. 16-39.
- Bechhofer, R. E. (1960): "A multiplicative model for analyzing variances which are affected by several factors," Journal of the American Statistical Association, Vol. 55, No. 290, pp. 245-264.
- Bechhofer, R. E. (1968a): "Single-stage procedures for ranking multiply-classified variances of normal populations," Technometrics, Vol. 10, No. 40, pp. 693-714.
- Bechhofer, R. E. (1968b): "Designing factorial experiments to rank variances," Transactions of the Twenty-Second Annual Conference of the American Society for Quality Control, pp. 69-73.
- Bechhofer, R. E., Dunnett, C. W. and Sobel, M. (1954): "A two-sample multiple decision procedure for ranking means of normal populations with a common unknown variance," Biometrika, Vol. 41, Parts 1 and 2, pp. 170-176.
- Bechhofer, R. E., Kiefer, J. and Sobel, M. (1965): Sequential Identification and Ranking Procedures (with special reference to Koopman-Darmois populations). University of Chicago Press.
- Bechhofer, R. E. and Sobel M. (1954): "A single-sample multiple-decision procedure for ranking variances of normal populations," Annals of Mathematical Statistics, Vol. 25, No. 2, pp. 273-289.
- Bechhofer, R. E. and Turnbull, B. W. (1974): "A  $(k+1)$ -decision single-stage selection procedure for comparing  $k$  normal means with a fixed known standard: the case of common known variance," Technical Report No. 242, Department of Operations Research, Cornell University. Submitted for publication.
- Bechhofer, R. E. and Turnbull, B. W. (1975a): "A  $(k+1)$ -decision two-stage selection procedure for comparing  $k$  normal means with a fixed known standard: the case of common unknown variance." In preparation.
- Bechhofer, R. E. and Turnbull, B. W. (1975b): "A  $(k+1)$ -decision single-stage selection procedure for comparing  $k$  normal variances with a fixed known standard." In preparation.
- Deely, J. J. and Gupta (1968): "On the properties of subset selection procedures," Sankhyā, A, Vol. 30, Part 1, pp. 37-49.

- Dudewicz, E. J. (1971): "Nonexistence of a single-sample selection procedure whose  $P(CS)$  is independent of the variances," South African Statistical Journal, Vol. 5, pp. 37-39.
- Dudewicz, E. J. and Dalal, S. R. (1971): "Allocation of observations in ranking and selection with unequal variances," a paper presented at the Symposium on Optimizing Methods in Statistics held at the Ohio State University, June 14-16, 1971. Accepted for publication in Sankhyā.
- Dunnett, C. W. (1955): "A multiple comparison procedure for comparing several treatments with a control," Journal of the American Statistical Association, Vol. 50, No. 272, pp. 1096-1121.
- Dunnett, C. W. (1960): "On selecting the largest of  $k$  normal population means," Journal of the Royal Statistical Society, B, Vol. 22, No. 1, pp. 1-40.
- Fabian, V. (1974): "Note on Anderson's sequential procedures with triangular boundary," Annals of Statistics, Vol. 2, No. 1, pp. 170-176.
- Fairweather, W. R. (1968): "Some extensions of Somerville's procedure for ranking means of normal populations," Biometrika, Vol. 55, No. 2, pp. 411-418.
- Gupta, S. S. (1956): "On a decision rule for a problem in ranking means," Institute of Statistics Mimeograph Series No. 150, University of North Carolina, Chapel Hill, N.C.
- Gupta, S. S. (1963): "Probability integrals of multivariate normal and multivariate  $t$ ," Annals of Mathematical Statistics, Vol. 34, No. 3, pp. 792-828.
- Gupta, S. S. (1965): "On some multiple decision (selection and ranking) rules," Technometrics, Vol. 7, No. 25, pp. 225-245.
- Gupta, S. S. and Panchapakesan, S. (1972): "On multiple decision procedures," Journal of Mathematical and Physical Sciences, Vol. VI, No. 1, pp. 1-72.
- Gupta, S. S. and Sobel, M. (1957): "On a statistic which arises in selection and ranking problems," Annals of Mathematical Statistics, Vol. 28, No. 4, pp. 957-967.
- Gupta, S. S. and Sobel, M. (1958): "On selecting a subset which contains all populations better than a standard," Annals of Mathematical Statistics, Vol. 29, No. 1, pp. 235-244.
- Gupta, S. S. and Sobel, M. (1960): "Selecting a subset containing the best of several binomial populations," Contributions to Probability and Statistics (ed. by Olkin et al), Stanford University Press, Stanford, California, pp. 1-25.
- Gupta, S. S. and Sobel, M. (1962): "On selecting a subset containing the population with the smallest variance," Biometrika, Vol. 49, Parts 3 and 4, pp. 495-507.

- Hall, W. J. (1959): "The most economical character of some Bechhofer and Sobel decision rules," Annals of Mathematical Statistics, Vol. 30, No. 4, pp. 964-969.
- Huyett, M. J. and Sobel, M. (1957): "Selecting the best one of several binomial populations," The Bell System Technical Journal, Vol. 36, pp. 537-576.
- Mahamunulu, D. M. (1967): "Some fixed-sample ranking and selection problems," Annals of Mathematical Statistics, Vol. 38, No. 4, pp. 1079-1091.
- Paulson, E. (1964): "A sequential procedure for selecting the population with the largest mean from k normal populations," Annals of Mathematical Statistics, Vol. 35, No. 1, pp. 174-180.
- Perng, S. K. (1969): "A comparison of the asymptotic expected sample sizes of two sequential procedures for ranking problem," Annals of Mathematical Statistics, Vol. 40, No. 6, pp. 619-632.
- Raiffa, H. and Schlaifer, R. (1961): "Selection of the best of several processes," Chapter 5B of Applied Statistical Decision Theory, Graduate School of Business Administration, Harvard University.
- Ramberg, J. S. (1966): "A comparison of the performance characteristics of two sequential procedures for ranking the means of normal populations," Technical Report No. 4, Department of Operations Research, Cornell University.
- Rinott, Y. (1974): "On two stage procedures for selecting the population with the largest mean from several normal populations with unknown variances," Report, Department of Mathematics, Cornell University. Submitted for publication.
- Santner, T. J. (1975): "A restricted subset selection approach to ranking and selection problems." Accepted for publication in the Annals of Statistics.
- Sobel, M. (1954-5): "Sequential procedures for selecting the best exponential population," Proceedings of the Third Berkeley Symposium on Mathematical Statistics and Probability, Vol. 5, pp. 99-110.
- Somerville, P. N. (1954): "Some problems of optimum sampling," Biometrika, Vol. 41, Parts 3 and 4, pp. 420-429.
- Tamhane, A. (1975): "A two-stage minimax procedure for selecting the population with the largest mean from k normal populations." Ph.D. dissertation (in preparation), Department of Operations Research, Cornell University.
- Wetherill, G.B. and Ofosu, J.B. (1974): "Selection of the best of k normal populations," Journal of the Royal Statistical Society, C, Vol. 23, No. 3, pp. 253-277.

MAXIMUM INFORMATION FROM  
FIELD EXPERIMENTS

Marion R. Bryson

US Army Combat Developments  
Experimentation Command  
Fort Ord, California 93941

ABSTRACT. The constraints of limited time, limited resources, and large inherent sample variance characterize army field experimentation. For these reasons the significance level, the power, or both, of tests of hypotheses are usually not as high as one would desire. The decision must be made as to whether low power or low significance is less undesirable-- or, perhaps, we can eat our cake and have it, too.

This paper briefly describes the US Army Combat Developments Experimentation Command and its mission to perform field experiments. It then discusses a typical example which brings out the major problems in this type experimentation. Methods of dealing with a large number of sources of variation are discussed.

1. INTRODUCTION. The process known as combat developments includes the planning of the future army; how it will be equipped, how it will be organized, how it will fight. The specific products which are produced to address these topics are materiel need documents, tables of organization and equipment, and field manuals. Often in the development of these products, a concept or a piece of equipment must be tested with troops. It is the mission of the Combat Developments Experimentation Command (CDEC) to design and conduct field experiments in these areas. The players in these experiments are trained army troops, the equipment is operational or prototype hardware, the environment is a realistic combat environment. CDEC deals in small unit experimentation, usually smaller than company size elements on each side.

The sources of variation in field experimentation are more difficult to handle than in many types of experimental situations. This is caused by the necessary freedom given the players to behave as if they were in a combat environment. Dealing with this variation is the major subject of the paper.

2. THE CDEC MISSION. It is quite appropriate that representatives of CDEC should participate in the Army Design of Experiments Conference. We are one of only two organizations in the army with the word experiment (in some form) in their title. CDEC is unique in the Army, DOD, and probably in the world. Its sole mission is to perform field experiments in which the equipment is put in the hands of the troops to be used in an operationally relevant environment. This is as distinguished from field tests, engineering tests, and operational tests in which the major concern is the operation of the equipment rather than the interaction of the equipment with the personnel and the environment.

CDEC is a service organization. With rare exceptions the requirements for experimental data comes from an organization outside of CDEC. This organization tasks CDEC through its higher headquarters, the Training and Doctrine Command (TRADOC); and acts as proponent for the experiment. The major customers for the CDEC product are the TRADOC schools and centers -- the Combined Arms Center, Armor, Infantry, Artillery, Aviation, and Air Defense schools. CDEC provides data to satisfy one of three requirements. The first is to compare two or more alternatives. These alternatives may be hardware systems, strategies, or organizations. The second is to compare one or more alternatives with a standard system. The third is to provide data for use in computer models, simulations, or war games. The data may be used for model validation or for data input.

CDEC is a subordinate command of TRADOC. The staff section in TRADOC responsible for CDEC is the Deputy Chief of Staff for Combat Developments. The Operational Test and Evaluation Agency (OTEA) monitors the work of CDEC as well as all operational tests throughout the army. The Commander of OTEA chairs the Test Schedule and Review Committee (TSARC) which meets twice yearly to review the army test program. The TSARC, a general officer committee, manages the Five Year Test Program. This program consists of all army operational tests, joint tests, and force development tests and experiments.

Within CDEC, the experimentation mission is performed by three major divisions. The first is responsible for developing the overall CDEC program, working with the proponents in identifying the problems, and designing the experiment. The second division performs the experiment, analyzes the data and writes the report. The third division maintains and operates the highly complex system of instrumentation necessary to collect the data.

The instrumentation system at CDEC consists of five major categories of hardware.

a. Instrumentation Control. This is a system of computers which include a GE M605, an XDS 930, and two XDS 910's. CDEC is currently in the process of changing over to a new computer control system.

b. Position Location System. This system consists of a series of movable transmission towers which can be located anywhere on the range, a series of small transponders which automatically send and receive messages, and two relay stations which interface with the computer. The computer, by sending messages to and receiving messages from the transponders via the transmission towers, can compute the location of the transponders on a second by second basis. Each player element carries a uniquely coded transponder to identify his location to the computer. A continuous location record is kept of all players by the computer.

c. Simulated Fire. The simulated fire system consists of 60 small laser generators. These eye safe lasers can be bore sighted with a weapon and wired so that when the trigger is pulled a coded laser beam is emitted rather than a projectile. When a laser beam is emitted, a message to that effect is sent to the computer through the transponder, automatically. If the laser beam strikes a target, a laser sensor on the target is activated. This message is sent to the computer through the transponder on the target. This "hit" does not necessarily mean the target was "damaged" or "killed" by the exchange. The computer now possesses the following knowledge from the engagement: who fired, the weapon type, the location of the firer, who was the target, and the location of the target. The computer then determines the range of engagement and the aspect and speed of the target. Then using probability of kill functions resident in memory, the actual probability of kill is computed. A random number is drawn by the computer to determine whether damage or a kill has been inflicted by the engagement. If the target is assessed as a casualty it is sent a message to that effect and the laser weapon of that player is deactivated by the computer so he can't shoot any more. The target also detonates a smoke grenade and displays a distinctive panel to inform the other players in the game of his status.

d. Live Fire. There are two computer controlled live fire ranges, one offensive and one defensive. The man-sized targets can be programmed

to come up in an exposed position on any preassigned schedule, to fire blanks, to duck for a programmed time if a bullet comes close, and to fall down and stay down if hit.

e. Support Instrumentation. The systems represented in the support instrumentation are additional data gathering and storage systems and control systems. There are two radar systems for target tracking, there are cameras to record, manually or automatically, what is taking place, there are several multiple channel voice recording systems to record by radio or telephone all that goes on in a trial, and there is a master timing system. This timing system simultaneously time tags all records kept of the experiment for the purpose of cross checking redundant data records.

The geographic area used in CDEC experiments is Hunter Liggett Military Reservation at Jolon, California. This reservation has 166,000 acres consisting of all terrain types from flat treeless plains areas to heavily forested rugged mountains. The weather is mild and rainy in the winter, hot and dry in the summer. CDEC controls the air space over Hunter Liggett to an altitude of 10,000 feet.

3. LEVELS OF DATA REFINEMENT. CDEC recognizes six levels of data refinement. The hierarchy represented in these levels is valuable in discussing the form and nature of experimental results desired by the proponent. The six levels are defined here:

a. Level 1 - Raw Data. Data at Level 1 are data in their original form. This includes data on:

- (1) Data collection forms used by a controller or data collector.
- (2) Magnetic tape. This refers to the original tape used during the conduct of the experiment.
- (3) Camera film, unedited.
- (4) Voice Recording System tape (VRS), unedited.
- (5) Punch cards or hard copy print-outs of the contents of (2).

At this level no data purification has taken place except the elimination of data which are obviously invalid, such as that caused by an instrumentation malfunction.



b. Level 2 - Reduced Data.

Data at Level 2 have been taken from the raw data form and consolidated for evaluation of data quality. This first level of data refinement is performed soon after the data are collected, usually within one day.

c. Level 3 - Ordered Data. Data at Level 3 have been checked for accuracy and placed in logical order. Data at this level may be produced in one or more of the following forms:

- (1) Ordered computer print-out.
- (2) Typed listing.
- (3) Purified and ordered tape.
- (4) Edited camera film.
- (5) Edited VRS tape.
- (6) Punch cards.

Data in this form will have been thoroughly purified. Invalid data will have been identified and eliminated. The data may be ordered on any of several dimensions such as:

- (1) Measurement taken, e.g., time to detect, total exposure time, range to target, or crossing velocity.
- (2) Trials.
- (3) Player elements.
- (4) Time of day.

No arithmetic operations, with the possible exception of counting, are applied to data at this level. Data at Level 3 are distinguished from data at Level 2 by the terms "edited" and "ordered."

d. Level 4 - Descriptive Data. Data at Level 4 have been subjected to any of several elementary statistical and mathematical operations. Data in this form will usually consist of:

- (1) Frequency distributions. Such distributions may be in tabular form, histograms, or curves smoothed by eye.
- (2) Computed means, variances and standard deviations of distributions.
- (3) Computed medians, modes, ranges, quartiles, deciles, etc.
- (4) Computed percentages.
- (5) Computed correlation coefficients.

Processing of data to Level 4 does not include drawing inferences. Significance of the difference between any of the measurements is not given. Data at this level differ from those at Level 3 in that they are summarized and combined into more concise measures. Data at this level should not go beyond what may be called "data descriptive of what happened in the experiment."

e. Level 5 - Inferred Data. Data at Level 5 have undergone statistical tests of hypothesis and/or interval estimation. The design of the experiment is constructed so that the specific planned tests and estimates can be made. Although there are many tests of hypothesis in the literature, those techniques which will most often be used at this level of data refinement are:

- (1) "Student's" t test.
- (2) Chi square test.
- (3) Snedecor's F test.
- (4) Analysis of variance.
- (5) Regression analysis.
- (6) Any of several standard non-parametric tests.

Hypotheses to be tested will include testing whether:

- (1) An observed sample represents a sample from a standard or known distribution.
- (2) Two (or more) observed samples are both (all) samples from the same, perhaps unknown distribution.
- (3) A sample parametric estimate such as a mean, median, standard deviation, or regression coefficient differs from a given fixed value.
- (4) Two or more independent sample parametric estimates differ from each other.

Data at this level do not include statistical inferences on ex post facto questions generated either from an outside source or by the results themselves. Level 5 data are limited to preplanned statistical analysis of the data generated in the experiment.

f. Level 6 - Analyzed Data. Data at Level 6 have received a more thorough and detailed analysis than at Level 5. Analysis at this level is characterized by two features:

- (1) It answers questions or investigates areas not planned for in the original experiment or,
- (2) It combines the results of the experiment with data obtained elsewhere in order to generalize the conclusions which may be drawn.

A classic example of Level 6 analysis is the insertion of experimentally derived data into a combat model to generate new information to help answer force mix questions. A second example is the use of experimentally derived intervisibility data to determine the probability that a target is available when a tube launched guided projectile arrives. Another way to distinguish analyses at Level 5 and Level 6 is that data at Level 5 are pure data, are derived by deductive reasoning, and concern themselves solely with the quantitative nature of the population from which the experimental sample was drawn. Data at Level 6, on the other hand, answer operational questions, require inductive reasoning, and use the experimental results to assist in shedding light on the key military issues.

Although CDEC reports to the proponent on data at Level 3, the subject of the remainder of this paper concerns analyses at Levels 4 and 5. Analysis at Level 6 is generally done by an analytic organization rather than an experimentation organization.

4. A TYPICAL EXPERIMENT. In this example will be described some design problems which are characteristic of the type of experiments conducted at CDEC. A general solution to most of these problems will be indicated. The following paper by Dr. Mallios will discuss some specific techniques that have been used to solve some of the more troublesome problems.

This example is hypothetical (barely). Barely, only because it has been simplified to its basic important elements. It is very typical. Let us say there are two helicopter mounted target acquisition devices the proponent wants to compare. He also wants to compare the devices at two ranges, i.e., he suspects a device range interaction. (Generally there are many other independent variables he is interested in such as the size of the target, is the target moving or stationary, is the target hot or cold (IR emissions), is the helicopter hovering or moving, etc.) Let us say further in our 2 x 2 experiment that we have time, money, fuel, etc., for exactly 48 trials. The dependent variable is "time to detect." One would likely propose such a design and model as is shown in Table 1.

TABLE 1 - BASIC DESIGN

		DEVICE	
		A	B
RANGE	1.	12	12
	2.	12	12

MODEL:  $y = m + d + r + dr + e$  (1)

ANALYSIS OF VARIANCE

	d.f.
Devices (d)	1
Range (r)	1
Interaction (dr)	1
Error (e)	44

Fine--it will work. But we must have players. How many players? Certainly at least 1 and at most 48. Let's look at those two extremes. A proposed model for the case of one player would be,

$$y = m + d + r + dr + t + e \quad (2)$$

where  $t$  is the learning effect. Certainly he wouldn't have the same expected behavior on the first trial as on the 48th trial. This learning effect is neither linear nor random. Dealing with it presents a significant problem. Moreover, one must keep in mind the population about which we are making inferences. In terms of people, that population is the group of people who may use the device to detect targets in combat. Certainly, making inferences about that population with a sample of one player is poor procedure.

The 48 player proposition does not suffer from either of these shortcomings. It is shown in many experiments that the greatest single cause of variation in experimental results is the difference between players. The postulated model for this case is,

$$y = m + d + r + dr + p + e \quad (3)$$

The player effect ( $p$ ), is confounded with the error. It occurs as a term in the expected mean square of all four sources of variation shown in the ANOVA of Table 1. Since the player variance is so large, it overpowers the  $F$  ratio and nothing but the most obvious treatment effects show up as significant. (This is apart from the logistical problem of finding and training that many qualified players.)

Now that we have disposed of those two options let us look at another and a more reasonable player option. Let us use four players, each one playing in three trials in each of the cells of the design in Table 1. Since each player plays in 12 trials, each of the cells can contain one of each of the player orders: 1, 2, . . . 12. A model for this design is,

$$y = m + d + r + dr + p + t + e \quad (4)$$

where all interactions except the device X range interaction are assumed away. This design is better. We can isolate the player and learning effects, but there is still the question of sample size. Is a sample of 4 from all possible soldiers an adequate representation?

A final, and best alternative we will consider is one which uses 12 players, each one playing once in each of the four cells. Again we can balance the order effect within the cells. The postulated model is the same as in equation (4), however, the analysis of variance would have re-distributed degrees of freedom and different coefficients in the expected mean squares. The analysis of variance is shown in Table 2.

TABLE 2  
ANALYSIS OF VARIANCE

Source of variation	d.f.
Devices	1
Range	1
Interaction	1
Players	11
Order	3
Error	30

Since "Players" would normally be a random factor, more correctly the error term for the main effects of range and device would be their interaction with player. We have assumed this to be zero which makes "error" the denominator of all F ratios. If one is unwilling to assume zero interactions, the player interactions can be computed and used as error terms. In this case, the player X device X range interaction is confounded with order so no legitimate test exists for the range X device interaction.

All of the foregoing is merely the peak of the iceberg. The real problems in field experimentation center around dealing with such factors as:

a. Carry over effect. This effect is that influence the treatment combination experienced by the player in trial  $i$  has upon his performance in trial  $i + 1$ .

b. Environmental factors.

(1) Dust.

(2) Wind.

(3) Atmospheric attenuation.

(4) Light level.

(5) Sun angle.

c. Target location factors.

(1) Target to background contrast.

(2) Background clutter.

(3) Shape contrast.

It is clearly impossible to control all of these sources of variation. Each one may have an effect on the measurement of interest in a given trial. One solution is to balance on these factors, i.e., assure in the design that whatever the level of these factors is, that level occurs with equal frequency in each of the four cells in Table 1. This can be achieved physically by having a single target and four observers, two at each range with one of the devices at each range. Perform the detection task simultaneously. Then, as nearly as possible, we can say that the differences in detection time are due to the difference in the main effects and their interaction (plus random error). We perform a sequence of 12 such games with the proper player and order design. Now the analysis shown in Table 2 is valid, or is it? When the main effect mean squares are computed, to be sure, the variance caused by the above mentioned sources is absent. But when the error mean square is computed it shows up in all of its glory. What happens, then, is that the expected mean square of the denominator of the F ratio contains terms not found in the numerator. This leads to small, inappropriate F ratios.

This brings us to the last straw. To avoid the problem of inappropriate F ratios and still have degrees of freedom left for error, we can randomize the assignment of treatment combinations to target locations, days, and times of day. The terms mentioned above then occur in all expected mean squares and the result is valid F ratios.

5. COUP DE GRACE. In real life, do we really randomize? This only leads to tests of very low power. Which is more important, to get the very best estimates possible of the behavior of a system, or to get estimates of the behavior of a system which can be subjected to valid statistical tests? We think the former. It is for this reason that we favor balancing rather than randomizing. We still do tests of hypotheses but recognize clearly that these tests are often very conservative. In other words, we are more interested in obtaining the most accurate data possible at level 4 of refinement at the expense of doing rigorous level 5 analyses.

SAMPLE SIZE TRADE-OFFS  
AND  
THE CONSTRAINED MAXIMIZATION OF INFORMATION

William S. Mallios  
The BDM Corporation  
Monterey, California

ABSTRACT. Cost effectiveness is applied to sample size determination for field trial experimentation. Compound distributions are used in establishing trade-offs between sample size combinations and expected information. These trade-offs are used in maximizing information under cost constraints.

1. INTRODUCTION. This writing illustrates the use of sample size trade-offs in the design of field trials. Trade-offs are possible when sample size has more than one dimension. For example, a two dimensional sample size occurs when responses are to be drawn from each of a number ( $n$ ) of experimental units in each of a number ( $N$ ) of trials per fixed environment\*--units are nested in trials, and trials are nested in environments. Since a number of ( $n, N$ ) selections can give rise to approximately the same level of information, an appropriate selection is one which costs least, assuming other constraints have not been violated.

Sample size trade-offs provide a basis for answering the following questions regarding the design of field trials.

How was prior knowledge used in the design of the proposed experiment?

How much information is to be gained for a given expenditure? (1.1)

What is the loss (gain) in information as the expenditure is decreased (increased)?

Experimental objectives and information level (I.L.) are related as follows. Model specification is dependent on the objectives, while I.L. is inversely proportional to the variability associated with the model. Key to this relation is the model which reflects the objectives and dictates the design and method of analysis. In turn, variability can be quantified in terms of a variance, a generalized variance (the determinant of a covariance matrix associated with the model), or other appropriate measures.

Our use of I.L. is directed at quantifying information on the state of knowledge, not the state of uncertainty as in the Shannon formulation of information; see Pierce (1961). Thus, I.L. is more attuned to the definition of intrinsic accuracy (see Fisher (1950)) in describing the amount of information yielded by each member of a sample regarding a

---

\* When environments are random, sample size becomes three dimensional.



distributional parameter. However, with the diversity of definitions of "information", I.L. is left in general terms so as to allow for flexibility and further experimentation in applying the quantity. For example, a generalized variance (as the reciprocal of I.L.) is proportional to the square of the volume of the concentration ellipsoid (see Cramer(1946)), the geometrical representation of a distribution about its center of gravity. Or, if the objectives are formulated in terms of a linear combination of variables, the covariance matrix is reduced to a single variance as the inverse of the I.L. required, say, to attain a confidence interval of a certain width or to test for a certain difference between expectations. Regarding our loose definition of I.L., it should be recalled that Fisher (1950) tempered his definition as follows: "I am more inclined to examine the quantity (information) as it emerges from mathematical investigations and to judge of its utility by the free use of common sense, rather to impose it by formal definition".

Sample sizes should be based on the model, but oftentimes this is no easy matter. Consider, for example, a proposed field experiment where a yes or no response is to be measured from each of  $n$  units in each of  $N$  trials per environment. In addition, trials are to be quantified, if possible, on an ad hoc basis through measures of prevailing meteorological (met) conditions, and it is anticipated that the probability of response will vary between trials within environments. Our recourse to this problem involves, firstly, utilizing distributions which account for varying probability of response, secondly, getting prior estimates of the distribution's parameters, and thirdly, establishing trade-offs between sample sizes. Regarding the varying probabilities, compound distributions are applied. As to prior estimates, these can be obtained through analyses of data from exploratory trials, from past experiments of a similar nature, from computer simulation studies, from combinations thereof, or, as a last resort, through a good guess.

Section 2 contains background material on data collected in previous field trials in one particular environment. In Section 3, these data are used in establishing sample size trade-offs in maximizing I.L. under cost constraints. The aspects of model derivation, parameter estimation, and goodness of fit are considered in the appendices.

2. RESULTS OF DATA ANALYSIS FOR AN AIR POLLUTION EXPERIMENT. Consider an environment with an inversion occurring at a few hundred meters in height, the inversion defined as an atmospheric layer, of limited vertical extent, in which temperature increases with height. Beneath the inversion windflow is light and variable, with pollutant plumes emanating continuously from a fixed point source (say, a smokestack). The pollutant does not penetrate the inversion so that the plumes are dispersed by the winds and turbulence. These conditions can lead to large concentrations of ground level pollution, all of which mandate useful predictions of concentrations from proposed or existing sources in such environments.

Prior to proposed field experimentation, data were analyzed from an experiment in a similar environment. Therein, air samplers were located near ground level within an area of size 1200 meters by 1000 meters -- concentrations at varying heights above ground level were not considered. Dissemination of a pollutant simulant was from a fixed point source located at the center of the grid with responses drawn from  $n=35$  samplers, arranged in a uniform pattern, in each of  $N=22$  trials. The response from each sampler was concentration or the number of particles cumulated over a fixed span following dissemination.

Better known models, based largely on the normal distribution, are aimed at predicting concentration at given grid coordinates; e.g., under the Gaussian plume model, the effluent is assumed to expand normally in the horizontal and vertical directions as it moves downwind with a prevailing wind; see Panofsky (1969). However, these models are known to be inadequate when eddy sizes are sufficiently large to move the effluent along a meandering path, as was the case in these previous trials. Instead of predictions at given grid coordinates (see Mallios (1969)), alternative consideration was given to models which predict percentages of the grid area subjected to given ranges of concentration and which account for between trial variation in these percentages. Accordingly, based on compliance with experimental objectives, sampler responses were categorized, on a per trial basis, to one of the four particle number ranges

$$C_1:(0,99), C_2:(100,999), C_3:(1000,9999), C_4:(\geq 10,000); \quad (2.1)$$

e.g., samplers with particle counts between 100 and 999 were assigned to category  $C_2$ . With  $x_{ij}$  denoting the number of sampler responses assigned to category  $C_i$  in the  $j$ -th trial, we have  $\sum_{i=1}^4 x_{ij} = 35$ . The data are presented in Table 1.

Subjecting these data to a contingency table analysis leads to the obvious result that the multinomial distribution does not account for the between trial variation of  $\underline{x}_j = (x_{1j}, \dots, x_{4j})'$ ; i.e., assuming  $\underline{x}_j$  follows the multinomial distribution with probability  $\underline{p}_j = (p_{1j}, \dots, p_{4j})'$ ;

and setting 
$$\hat{p}_i = \frac{\sum_{j=1}^{22} x_{ij}}{\sum_{j=1}^{22} 35}$$

the hypothesis  $H: p_{ij} = \hat{p}_i$  is rejected in view of the value of

$$\sum_{i,j} (x_{ij} - n\hat{p}_i)^2 / n\hat{p}_i = 175.4,$$

which, under  $H$ , follows the  $\chi^2$  distribution with 63 degrees of freedom.

Readings of meteorological (met) instrumentation, operational during these trials, were evaluated in attempting to classify trials into met regimes within which the multinomial probabilities were approximately constant. It was found that the instrumentation could not identify differing

Table 1. A per trial grouping of sampler responses.

Trial	Categories							
	C <sub>1</sub> : (0,99)		C <sub>2</sub> : (100,999)		C <sub>3</sub> : (1000,9999)		C <sub>4</sub> : (>10,000)	
	%	(No.)	%	(No.)	%	(No.)	%	(No.)
1	67	(23)	11	( 4)	11	( 4)	11	( 4)
2	49	(17)	23	( 8)	14	( 5)	14	( 5)
3	74	(26)	14	( 5)	6	( 2)	6	( 2)
4	37	(13)	20	( 7)	32	(11)	11	( 4)
5	66	(23)	23	( 8)	8	( 3)	3	( 1)
6	63	(22)	11	( 4)	6	( 2)	20	( 7)
7	34	(12)	14	( 5)	34	(12)	18	( 6)
8	60	(21)	18	( 6)	11	( 4)	11	( 4)
9	14	( 5)	34	(12)	29	(10)	23	( 8)
10	37	(13)	43	(15)	6	( 2)	14	( 5)
11	29	(10)	52	(18)	8	( 3)	11	( 4)
12	37	(13)	34	(12)	11	( 4)	18	( 6)
13	37	(13)	41	(14)	8	( 3)	14	( 5)
14	43	(15)	29	(10)	14	( 5)	14	( 5)
15	18	( 6)	18	( 6)	33	(12)	31	(11)
16	57	(20)	0	( 0)	40	(14)	3	( 1)
17	34	(12)	18	( 6)	34	(12)	14	( 5)
18	37	(13)	17	( 6)	23	( 8)	23	( 8)
19	49	(17)	26	( 9)	8	( 3)	17	( 6)
20	11	( 4)	52	(18)	23	( 8)	14	( 5)
21	40	(14)	17	( 6)	23	( 8)	20	( 7)
22	43	(15)	14	( 5)	26	( 9)	17	( 6)
Totals		(327)		(184)		(144)		(115)
Average	42.5%		23.9%		18.7%		14.9%	

regimes under these conditions, so that the 22 trials were taken as characteristic of one met regime. An area-coverage distribution applicable to this regime is obtained by compounding the multinomial and multivariate beta distributions. The result, given by

$$h(\underline{x}; n, \underline{\alpha}) = n! \beta(\alpha_1 + x_1, \alpha_2 + x_2, \alpha_3 + x_3, \alpha_4 + x_4) / \beta(\alpha_1, \alpha_2, \alpha_3, \alpha_4) \prod_{i=1}^4 x_i!, \quad (2.2)$$

is termed the multinomial-multivariate beta (MMB) distribution, where the  $\alpha_i > 1$  are parameters of the quadrivariate beta distribution; see Appendix 1 for the moments of (2.2), Appendix 2 for estimation of the  $\alpha_i$ , and Appendix 3 for goodness of fit of (2.2) the data in Table 1.

It should be noted that (2.2) is a conglomerate distribution in that it should account for the between trial variation in  $\underline{x}$  even if the pollutant source were varied between trials and/or if there were substantial measurement error and/or if trials could be classified into distinct met regimes and/or if samplers were positioned varying heights above ground level. However, the more the sources of unidentified variation, the greater the variability and the less the I.L., so that one should always isolate sources of variation when possible.

3. INFORMATION CONTOURS AND OPTIMAL SAMPLE SIZE SELECTIONS. Before addressing the questions in (1.1), we first quantify the change in I.L. as the sample size is varied. Thereupon, an optimal  $(n, N)$  combination, say  $(n_0, N_0)$ , is that which maximizes I.L. under constraints of fixed costs.

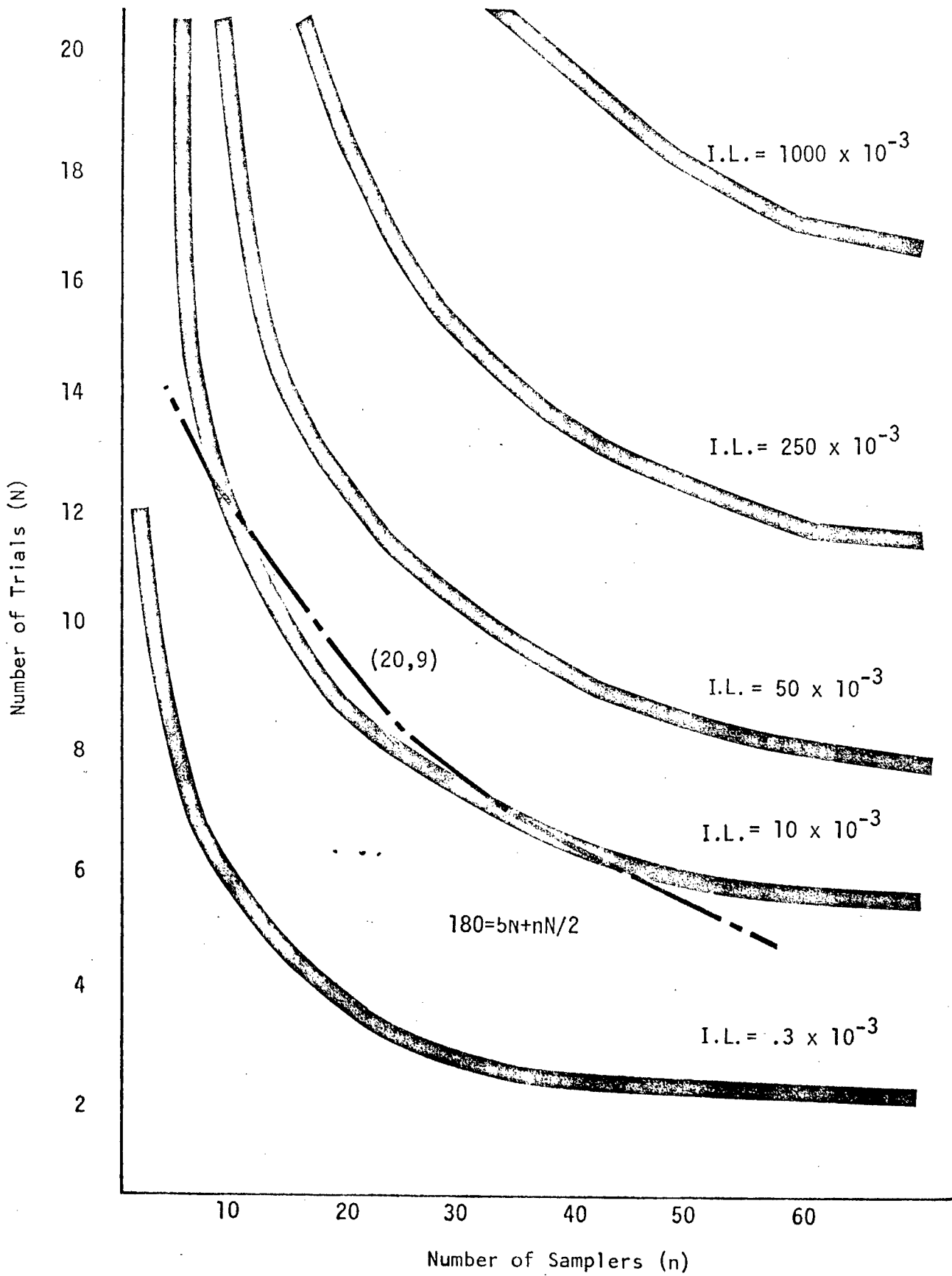
In this problem, I.L. could be taken as the inverse of the generalized variance of  $\underline{a}$ , the maximum likelihood estimate of  $\underline{\alpha}$ ; i.e., under fairly general conditions, it is known that variance  $\underline{a} = \phi^{-1}/N$ , where

$$\phi = -E(\partial^2 \log h / \partial \alpha_i \partial \alpha_j)$$

and  $h$  denotes MMB distribution. I.L. is then estimated by  $N|\phi|$  after  $\underline{a}$  is substituted for  $\underline{\alpha}$ . Alternatively, I.L. could be taken as the inverse of variance  $(\underline{\ell}'\underline{x}) = \underline{\ell}'V\underline{\ell}$ , where  $V$  = variance  $(\underline{x})$  and  $\underline{\ell}'\underline{x}$  is an appropriate linear combination of the  $x_i$ ; e.g., the  $\ell_i$  might be defined as the mid-points of the four categories given in (2.1). As a matter of illustration, we take the former as the measure of I.L.

Figure 1 contains contours of fixed I.L. =  $N|\phi(\underline{a} = \underline{\alpha})|$  values, ranging from  $.3 \times 10^{-3}$  to  $1000 \times 10^{-3}$ , for varying values of  $n$  and  $N$ . If, for example,  $n = 30$  and  $N$  is increased from 6 to 10, the I.L. is increased, roughly, from  $5 \times 10^{-3}$  to  $50 \times 10^{-3}$ , a 900% increase in I.L. For this application, this is to illustrate the  $N$  should be increased at the expense of  $n$  and that large  $n$  adds little to I.L. when  $N$  is held constant; e.g., if the area of interest were saturated with samplers and trials were few in number, then a great deal would be known about these few trials, but

Figure 1. Information (I.L.) contours for varying values of  $n$  and  $N$ , and the selection of an optimal  $(N, N)$  combination



little would be known about trials in general (which form a major source of variation).

To maximize I.L. subject to fixed costs, we employ the simple cost model

$$C = C_B + C_L + NC_T + nNC_S, \quad (3.1)$$

where  $C$  denotes total funds available;  $C_B$  is the base cost;  $C_L$  is the expected loss in funds due to materialized risks;  $C_S$  is the cost per sampler and  $C_T$  the cost per trial. Substitution of

$C = 200$ ,  $C_B = 15$ ,  $C_L = 5$ ,  $C_T = 10$ , and  $C_S = 1/2$  into (5.1) yields

$$180 = 10N + nN/2. \quad (3.2)$$

We could introduce a Lagrangian multiplier,  $\lambda$ , and differentiate  $N|\phi| - \lambda(180 - 10N - nN/2)$  with respect to  $N$ ,  $n$ , and  $\lambda$  in determining  $(n_o, N_o)$ . However, a graphical approach is the easiest recourse, i.e., superimposing (3.2) onto the contours in Figure 1, we choose  $(n_o, N_o)$  as that combination corresponding to that maximum value of I.L. on the curve (3.2). From the plot of (3.2), given in Figure 1, it is seen that (20,9) is an adequate approximation to  $(n_o, N_o)$ .

**4. CONCLUDING REMARKS.** Now we are in a position to answer the questions in (1.1). Firstly, prior knowledge has been utilized in the form of the depiction in Figure 1. Regarding the second question, an I.L. of approximately  $15 \times 10^{-3}$  is to be gained for a fixed expenditure of  $C = 200$ . Relating I.L. to center of gravity (see Section 1) means that I.L. =  $15 \times 10^{-3}$  is to be interpreted on a relative basis. Had I.L. been equated to the inverse of  $\underline{\ell}^T V \underline{\ell}$  (as discussed in Section 3), absolute interpretations could have been given; e.g., in this case, the expenditure of  $C = 200$  would give rise to an I.L. which, say, would lead to a confidence interval of a certain width.

The third question in (1.1) is answered by varying the value of  $C$  in (3.1) which, in turn, shifts the cost curve in Figure 1 up or down. In this manner, one can determine the loss or gain in I.L. as the budget is increased or decreased. If, for example, the budget is decreased to the extent that I.L. is deemed insufficient to answer the experimental objectives, thought should be given to whether the experiment should be conducted.

APPENDIX 1  
THE MMB DISTRIBUTION

Let the multinomial distribution,

$$f(\underline{x}; n, \underline{p}) = n! \prod_{i=1}^r (p_i^{x_i} / x_i!), \quad E(\underline{x}) = n \underline{p}, \quad \sum_{i=1}^r x_{ij} = n, \quad \sum_{i=1}^r p_i = 1,$$

describe the within trial variation of  $\underline{x} = (x_1, \dots, x_r)'$ . If  $\underline{p}$  is constant between trials, then this distribution also accounts for the between trial variation in  $\underline{x}$ . However,  $\underline{p}$  may vary between trials, even when environmental conditions are closely monitored and the scheduling of trials is arranged such that these conditions are as homogenous as possible. Such variation in  $\underline{p}$  might be described by the multivariate beta distribution,

$$g(\underline{p}; \underline{\alpha}) = \frac{1}{\pi} \prod_{i=1}^r p_i^{\alpha_i - 1} / \beta(\underline{\alpha}), \quad \underline{\alpha} = (\alpha_1, \dots, \alpha_r)' > \underline{0},$$

where

$$\beta(\underline{\alpha}) = \frac{1}{\pi} \frac{\Gamma(\alpha_1) \dots \Gamma(\alpha_r)}{\Gamma(\sum_{i=1}^r \alpha_i)}.$$

Compounding  $f(\underline{x}; n, \underline{p})$  and  $g(\underline{p}; \underline{\alpha})$  (see Feller (1957)) and letting  $r=4$  for the application in Section 2, we have

$$h(\underline{x}; n, \underline{\alpha}) = \int_0^1 \int_0^{1-p_1} \int_0^{1-p_1-p_2} \int_0^{1-p_1-p_2-p_3} f(\underline{x}; n, \underline{p}) g(\underline{p}; \underline{\alpha}) dp_4,$$

which, after integration, reduces to (2.2). This is an extension of a result of Skellam (1948) who compounded the binomial and beta distributions. From the general case (given by Moiseman (1962)), it follows that the  $(k_1, k_2, k_3)$ -th factorial moment of  $h(\underline{x}; n, \underline{\alpha})$  for  $r = 4$  is

$$\mu\{k_1, k_2, k_3\} = n^{\sum_{i=1}^3 k_i} \beta(k_1 + \alpha_1, k_2 + \alpha_2, k_3 + \alpha_3, \alpha_4) / \beta(\alpha_1, \alpha_2, \alpha_3, \alpha_4).$$

Hence,

$$E(x_i/n) = \alpha_i / \sum_{\ell=1}^4 \alpha_\ell$$

$$\text{var}(x_i/n) = \alpha_i (\sum_{\ell=1}^4 \alpha_\ell - \alpha_i) (n + \sum_{\ell=1}^4 \alpha_\ell)^2 / (1 + \sum_{\ell=1}^4 \alpha_\ell) n \quad (\text{A.1.1})$$

$$\text{cov}(x_i/n, x_{i'}/n) = -\alpha_i \alpha_{i'} (\sum_{\ell=1}^4 \alpha_\ell + n) / (\sum_{\ell=1}^4 \alpha_\ell)^2 (1 + \sum_{\ell=1}^4 \alpha_\ell) n$$

In summary,  $h(\underline{x}; n, \underline{\alpha})$  is intended to account for the between trial variation in  $\underline{x}$  when  $\underline{p}$  varies between trials. In general, when a contingency table with mixed borders (see Cramer (1946)) leads to a significant  $\chi^2$  result and when an alternative to the multinomial distribution is desired, application of the MMB distribution is a natural recourse.

APPENDIX 2

MAXIMUM LIKELIHOOD ESTIMATION OF PARAMETERS OF THE MMB DISTRIBUTION

In fitting the MMB distribution to the data in Table 1 through maximum likelihood (m.l.) estimation, the log likelihood function is given by

$$\log L = \text{constant} +$$

$$\sum_{i,j}^{4,22} \log \Gamma(\alpha_i + x_{ij}) - 22 \log \Gamma(\sum_{i=1}^4 \alpha_i + 35) + 22 \log \Gamma(\sum_{i=1}^4 \alpha_i) - N \sum_{i=1}^4 \log \Gamma(\alpha_i)$$

The function  $\log \Gamma(\theta)$  is approximated by  $(\frac{1}{2}) \log(2\pi) + (\theta - \frac{1}{2}) \log \theta - \theta + 1/12\theta - 1/360\theta^3 + 1/1260\theta^5 - 1/1680\theta^7$  for  $\theta \geq 5$ . Repeated use of  $\Gamma(\theta) = (\theta - 1)\Gamma(\theta - 1)$  is made when  $\theta < 5$  (see Caratheodory (1958), page 297). The m.l. estimate of  $\alpha_i$ , say,  $\underline{a}_i$ , is obtained by taking partials of  $\log L$ , equating  $\partial \log L / \partial \alpha_i$  to zero, and solving for that value which maximizes  $\log L$ . To calculate  $\underline{a}_i$  by iterative methods, an initial value, say  $\underline{a}_i^{(0)}$ , is required and can be obtained through method of moments estimation as follows. From (A.1.1) we have

$$R_{1ii'} = E(x_i) / E(x_{i'}) = \alpha_i / \alpha_{i'} \tag{A.2.1}$$

$$R_{2ii'} = \{E(x_i^2) - E(x_i)\} / \{E(x_{i'}^2) - E(x_{i'})\} = (\alpha_i^2 + \alpha_i) / (\alpha_{i'}^2 + \alpha_{i'})$$

These two relations can be used in identifying four equations in the four unknown  $\alpha_i$  after

$$\hat{R}_{1ii'} = \sum_{j=1}^{22} x_{ij} / \sum_{j=1}^{22} x_{i'j} \tag{A.2.2}$$

$$\hat{R}_{2ii'} = \left\{ \sum_{j=1}^{22} x_{ij}^2 - \sum_{j=1}^{22} x_{ij} \right\} / \left\{ \sum_{j=1}^{22} x_{i'j}^2 - \sum_{j=1}^{22} x_{i'j} \right\}$$

are substituted for  $R_{1ii'}$  and  $R_{2ii'}$ .

Except for the case  $r=2$ , a number of  $\underline{a}_i^{(0)}$  values may have to be considered, since repeated application has shown that many of these moment estimators lie nowhere in the neighborhood of  $\underline{a}_i$  -- in which case, non-convergence or coverage to a relative maximum may result. Among several possible values for  $\underline{a}_i^{(0)}$ , the appropriate one is that which minimizes



$\sum_{i=1}^r H_i^2(0)$ , where  $H_i(0) = \partial \log L / \partial \alpha_i |_{\underline{\alpha} = \underline{a}^{(0)}}$ . Additionally, it is anticipated that the MMB distribution, as it relates to the data in Table 1, will have a unique mode, in which case,  $\underline{a}^{(0)} > \underline{1}$ . Using these criteria to evaluate differing values of  $\underline{a}^{(0)}$  as defined by (A.2.2), we choose  $\underline{a}^{(0)} = (10.648, 5.993, 4.072, 3.804)'$ . For this value,  $H_1 = -.262$ ,  $H_2 = -.255$ ,  $H_3 = -.608$ ,  $H_4 = -.349$ , so that  $\underline{a}^{(0)}$  appears to lie in the neighborhood of  $\underline{a}$ .

Convergence to  $\underline{a}$  utilizes a modified Newton-Raphson procedure as follows. The correction to  $\underline{a}^{(t)}$ , the value obtained in the  $t$ -th iterative cycle, is  $c \underline{d}^{(t)}$ , where  $\underline{d}^{(t)} = G_{(t-1)}^{-1} \underline{g}_{(t-1)}$ ,  $G_{(t)}$  is an  $r \times r$  matrix with typical element  $\partial^2 \log L / \partial \alpha_i \partial \alpha_j |_{\underline{\alpha} = \underline{a}^{(t)}}$ , and  $\underline{g}_{(t)}$  is an  $r \times 1$  vector with typical element  $-H_i(t)$ ;  $c$  takes the values .1, .2, ..., 1.0 with the selected value of  $\underline{a}^{(t)}$  taken as that for which  $\sum_{i=1}^r H_i^2(t)$  is minimized.

Values of  $\underline{a}^{(t)}$  through six iterative cycles are as follows:

$$\begin{aligned}
 \underline{a}^{(1)} &= (7.73646, 4.35829, 3.46059, 2.95983) \\
 \underline{a}^{(2)} &= (7.90812, 4.45444, 3.54099, 3.05283) \\
 \underline{a}^{(3)} &= (7.89936, 4.44951, 3.53670, 3.04752) \\
 \underline{a}^{(4)} &= (7.90126, 4.45056, 3.53759, 3.04854) \\
 \underline{a}^{(5)} &= (7.90155, 4.45074, 3.53774, 3.04876) \\
 \underline{a}^{(6)} &= (7.90148, 4.45071, 3.53773, 3.04877)
 \end{aligned}$$

Substitution of  $\underline{a}^{(6)} = \underline{a}$  for  $\underline{\alpha}$  and 35 for  $n$  in (A.1.1) leads to (.417, .235, .187, .161) as the estimate of  $E[(1/n)\underline{x}]$  and

$$\begin{bmatrix}
 .0187, & -.0075, & -.0052, & -.0060 \\
 & .0138, & -.0034, & -.0029 \\
 & & .0117, & -.0023 \\
 & & & .0104
 \end{bmatrix}$$

as the estimate of variance  $[(1/n)\underline{x}]$ .

APPENDIX 3.  
GOODNESS OF FIT

Goodness of fit is illustrated through the distribution of

$$y_i = \sum_{j \neq i}^4 x_{ij}, \text{ where}$$

$$h(y_i) = n! \beta(\sum_{j \neq i}^4 \alpha_{ij} + y_i, n - \alpha - y_i) / y_i! (n - y_i)! \beta(\sum_{j \neq i}^4 \alpha_{ij}, \alpha_i)$$

and

$$f(y_i) = n! (1 - p_i)^{y_i} p_i^{n - y_i} / y_i! (n - y_i)!$$

for the MMB and multinomial distributions, respectively. Table 2 presents groupings of observed and expected  $y_i$ ,  $i = 1, \dots, 4$ , for  $f$  and  $h$ . Ranges for each  $y_i$  were selected for demonstrating the greater spread of the MMB distribution, so that the goodness of fit statistic is applied loosely. For, not only are most observed cell frequencies quite small, but in three cases there are no degrees of freedom, i.e., for the MMB distribution, there is a loss of five degrees of freedom, four for the estimation of the  $\alpha_i$  and one due to the restriction that  $\sum_i x_{ij} = 35$ ; for the multinomial distribution, four degrees of freedom are lost, three for estimating  $p_1, p_2, p_3$ , and one due to  $\sum_i x_{ij} = 35$ .

Table 2. Goodness of fit of the MMB and Multinomial (M) distributions to the data in Table 1.

Ranges for $y_1$	Observed	Expected		Ranges for $y_2$	Observed	Expected	
		MMB	M			MMB	M
0-11	1	.576	.036	0-19	2	.785	.084
12-17	5	5.378	3.997	20-22	2	1.988	1.132
18-21	5	7.384	10.855	23-25	3	4.446	5.748
22-26	8	7.049	6.831	26-29	9	8.934	12.279
27-30	2	1.501	.279	30-32	5	4.787	2.647
31-35	1	.112	.002	33-35	1	1.060	.110
	<u>22</u>	<u>22.000</u>	<u>22.000</u>		<u>22</u>	<u>22.000</u>	<u>22.000</u>
$\chi^2$ value		8.476	538.042			2.364	56.078
Degrees of Freedom		1	2			1	2

Ranges for $y_3$	Observed	Expected		Ranges for $y_4$	Observed	Expected	
		MMB	M			MMB	M
0-21	1	.748	.061	0-24	1	1.365	.234
22-24	4	2.044	1.028	25-29	8	7.627	9.156
25-28	5	7.199	9.677	30-33	11	10.830	12.063
29-32	9	9.596	10.598	34-35	2	2.178	.547
33-35	3	2.413	.636				
	<u>22</u>	<u>22.000</u>	<u>22.000</u>		<u>22</u>	<u>22.000</u>	<u>22.000</u>
$\chi^2$ value		2.809	343.340			.144	6.608
Degrees of Freedom		0	1			-	0

## REFERENCES

- C. Caratheodory (1958). Theory of Functions. Chelsea Publishing Co., N.Y.
- H. Cramer (1946). Mathematical Methods of Statistics, Princeton University Press, Princeton, N.J.
- W. Feller (1957). An Introduction to Probability Theory and Its Applications. Volume 1. Wiley, N.Y.
- R. A. Fisher (1950). Contributions to Mathematical Statistics. Wiley, N.Y.
- W. S. Mallios (1969). A Monte Carlo Study of Small Sample Properties of Estimates of Parameters in Certain Non-Linear Regression Models. Under DOD Contract No. DAAD 09-68-C-0023.
- J. Mosimann (1962). On the Compound Multinomial Distribution, the Multivariate B-Distribution, and Correlations Among Proportions. *Biometrika* 49, 65-82.
- H. A. Panofsky (1969). Air Pollution Meteorology. *American Scientist* 57, 269-285.
- J. R. Pierce (1961). Symbols, Signals, and Noise. Harper, N.Y.
- J. G. Skellam (1948). A Probability Distribution Derived from the Binomial Distribution by Regarding the Probability of Success as a Variable Between Sets of Trials. *Journal of the Royal Statistical Society, Series B*, 10(2), 257-261.

LIST OF ATTENDEES  
TWENTIETH DESIGN CONFERENCE  
FORT BELVOIR, VIRGINIA

Commander  
ATTN: David L. Arp  
Naval Weapons Center  
Code 12  
China Lake, CA 93555

John Atkinson  
Food and Drug Admin  
200 C St SW  
Washington, DC 20204

Commander  
ATTN: Carl B. Bates  
US Army Concepts Anal Agcy  
8120 Woodmont Avenue  
Bethesda, MD 20014

Commander  
ATTN: John R. Baumgarten  
USAOTEA  
ATTN: DACS-TED-T  
Ft. Belvoir, VA 22060

Mr. R. J. Bartyczak  
Internal Revenue Svc  
1111 Const Ave, NW  
Washington, DC 20224

A. Stuart Baldwin  
ITT Research Institute  
1825 K St NW  
Washington, DC 20006

Prof. R. E. Bechhofer  
Dept. Operations Research  
Cornell University  
Ithaca, NY 14850

Mr. Kenneth Beane  
N.S.A. R-21  
Ft. Meade, MD 20755

Commander  
ATTN: Bob O. Benn  
Waterways Exper Sta  
P. O. Box 631  
Vicksburg, Miss. 39180

Commander  
USAMASAA  
ATTN: Alan W. Benton  
Aberdeen Proving Ground, MD 21005

Commander  
USAMSSA  
ATTN: Mary C. Berwanger  
Washington, DC 20301

Commander  
Picatinny Arsenal  
ATTN: SARPA-MI-M  
James G. Bevelock  
Dover, New Jersey 07801

Narayan Rangnath Bhalerao  
Mathematics Research Center  
610 Walnut St  
Madison, WIS 53706

Commander  
USAECOM  
ATTN: Avionics Lab  
Edwin Biser  
Ft. Monmouth, NJ 07703

Commander  
ARMCOM  
ATTN: AMSAR-QAA  
Richard M. Brugger  
Rock Island, ILL 61201

Commander  
USA CDEC  
ATTN: Dr. Marion Bryson  
Ft. Ord, CA 93941

Commander  
USAOTEA  
ATTN: DACS-TEZ-S  
Max Bunyard  
Ft. Belvoir, VA 22060

Commander  
WRAMC/WRAIR  
ATTN: Bob Burge  
Washington, DC 20012

Commander  
USAMSSA  
ATTN: Kenneth L. Busch  
Washington, DC 20210

Dr. Jagdish Chandra  
US Army Research Office  
Box CM, Duke Station  
Durham, NC 27706

Eugene Church (address on last page of list)

Commander  
Harry Diamond Laboratories  
ATTN: J. Michael Clodfelter  
Washington, DC 20438

Dr. Eugene A. Cogan  
HUMRRO  
300 N. Washington St.  
Alex, VA 22314

A. Clifford Cohen  
Dept. of Statistics  
University of GA  
Athens, GA 30602

Commander  
Naval Mat'l Command (Mat 03015)  
ATTN: Jacob L. Cohn  
Navy Dept  
Washington, DC 20360

Jerome Cornfield  
George Washington Univ.  
Washington, DC 20006

Commander  
WSMR  
ATTN: STEWS-QA  
Paul C. Cox  
WSMR, New Mexico 88002

John R. Crigler  
NSWC  
Code KCM  
Dahlgren, VA 22448

Commander  
USAMSAA  
ATTN: Dr. Larry A. Crow  
Aberdeen Proving Ground, MD 21005

Commander  
US Army Log. Ctr.  
ATTN: Jim Cunningham  
Ft. Lee, VA 23801

Commander  
USAECOM  
ATTN: AMSEL-NL-0  
Richard J. D'Accardi  
Ft. Monmouth, NJ 07703

Commander  
WSMR  
ATTN: NR-AM-I  
Oren N. Dalton  
WSMR, New Mexico 88002

Mr. Cuthbert Daniel  
RD 2  
Rhinebeck, NY 12572

Prof. H. A. David  
Dept of Statistics  
Iowa St University  
Ames, Iowa 50010

Commander  
USA MSL RD&E Lab  
ATTN: AMSMI-REO  
Joseph A. De Blaquiére  
Redstone Arsenal, AL 35809

Barbara De Florio  
System Planning Copr  
1500 Wilson Blvd  
Arlington, VA 22209

President  
USAIB  
ATTN: STEBC-TE-T  
Jimmie Deloach  
Ft. Benning, GA 31905

Commander  
TECOM  
ATTN: Gerard T. Dobrindt  
Aberdeen Proving Ground, MD 21005

Dr. Francis Dressel  
Army Research Office  
Box CM, Duke Sta  
Durham, NC 27706

L. A. Dye  
BDM Services Co.  
1920 Aline Ave  
Vienna, VA 22180

Commander  
Picatinny Arsenal  
ATTN: Dr. Seymore K. Einbinder  
Dover, NJ 07801

Dr. Churchill Eisenhart  
National Bureau of Standards  
Washington, DC 20230

Commander  
USA Missile Cmd  
ATTN: AMSMI-RRR  
Oskar M. Essenwanger  
Redstone Arsenal, AL 35809

Commander  
US Naval Ship R&D Ctr  
ATTN: Harry Feingold  
Bethesda, MD 20084

Commander  
USAOTEA  
ATTN: DACS-TET-S  
J. K. Felker  
Ft. Belvoir, VA 22060

Commander  
Frankford Arsenal  
ATTN: SARFA-PDR-B  
Paul D. Flynn  
Philadelphia, PA 19137

Walter D. Foster  
AFIP  
Washington, DC 20306

Commander  
Picatinny Arsenal  
ATTN: Burton Frank  
Dover, NJ 07801

Dr. Fred Frishman  
Internal Revenue Svc  
1111 Constitution Ave  
Washington, DC 20224

Phil D. Gilliland  
Internal Revenue Svc  
1201 E Street NW  
Washington, DC 20004

Commander  
Edgewood Arsenal  
ATTN: Biomed Lab  
Henry Goldstein  
Aberdeen Proving Ground, MD 21010

Thomas N. E. Greville  
Apt L-23  
Univ of Wisconsin-Math Res Ctr  
2022 Baltimore Road  
Rockville, MD 20853

Commander  
USA Ballistic Res Lab  
ATTN: Frank E. Grubbs  
Aberdeen Proving Ground, MD 21005

Dr. Richard Gibbons  
System Planning Corporation  
1500 Wilson Blvd.  
Arlington, VA 22209

Mr. R. L. Haines  
Canadian Def Lno Staff  
2450 Massachusetts Ave  
Washington, DC 20008

Commander  
Research Institute USAETL  
ATTN: J. Hannigan  
Ft. Belvoir, VA 22060

Mr. Bernard Harris  
Univ of Wis  
610 Walnut St  
Madison, WI 53706

Mr. Boyd Harshbarger  
Dept of Statistics  
VA Polytechnic Inst.  
Blacksburg, VA 24061

Mr. Anton Hauschild  
1126 Oriole Dr  
Corwells Heights, PA 19020

James L. Heigl, Jr  
Litton Industries  
490 L'Enfant Plaze  
Washington, DC 20024

Commander  
USA MERDC  
STSTFB-ZSG  
John Hennessy  
Ft. Belvoir, VA 22060

HQDA (DAMA-ARZ-D)  
ATTN: Dr. Hershner  
Washington, DC 20310

Commander  
USAOTEA  
ATTN: DACS-TET  
Robert Hertl  
Ft. Belvoir, VA 22060

Director  
NSA  
ATTN: Thomas N. Herzog  
Ft. Meade, MD 20755

Commander  
USAMRIID  
ATTN: Glen A. Higbee  
Ft. Detrick, MD

Commander  
USA MERDC  
ATTN: STS-FB-HM  
Paul Hopley  
Ft. Belvoir, VA 22060

Dr. Theodore Horner  
Suite 1104  
7479 Old Georgetown RD  
Bethesda, MD 20014

Mr. David Howes  
US Consumer Products Safety  
4501 West Bard  
Bethesda, MD 20207

Commander  
Harry Diamond Labs  
ATTN: J. C. Ingram  
Washington, DC 20438

Edwin Inselman (address on last page of  
list)

Professor J. S. Hunter  
School of Engineering and  
Applied Science  
Princeton University  
Princeton, NJ 08540

Commander  
USAOTEA  
ATTN: DACS-TED-T  
Daryl Jaschen  
Ft. Belvoir, VA 22060

Commander  
William P. Johnson  
ATTN: AMXBR-CAL  
Aberdeen Proving Ground, MD 21005

Dr. Ralph W. Jollensten  
Dept of Defense  
Ft. Meade, ME 20755

Commander  
Edgewood Arsenal  
ATTN: SAREA-CL-PO  
Robert V. Jolliffe  
Aberdeen Proving Ground, MD 21010

Commander  
Watervliet Arsenal  
ATTN: SARWV-RDD-SE  
Donald E. Jones  
Watervliet, NY 12189

Commander  
USAOTEA  
ATTN: DACS-TED-T  
Michael D. Jones  
Ft. Belvoir, VA 22060

Commander  
USAECOM  
AMSEO-MA-DM  
Walter Kasian  
Ft. Monmouth, NJ 07703

Commander  
Frankford Arsenal  
ATTN: SARFA-FCD-P  
Thomas Kelley  
Philadelphia, PA 19137

Mrs. Victoria Kojcsich  
Internal Revenue Svc  
1201 E St NW  
Washington, DC 20004

Mr. Dennis Koutras  
Poly Inst of New York  
333 Jay St  
Brooklyn, NY 11201

Commander  
Frankford Arsenal  
ATTN: SARFA-PDR-M  
June A. Kryst  
Philadelphia, PA 19137

Harry H. Ku  
National Bureau of Standards  
Washington, DC 20234



Commander  
USA MSL RD&E Lab  
ATTN: AMSMI-REO  
Christopher E. Kulas  
Redstone Arsenal, AL 35809

Prof. Solomon Kullback  
Dept of Statistics  
The Florida State Univ  
Tallahassee, Fl 32306

Dr. B. Kurkjian  
AMCRD-R  
US Army Materiel Command  
5001 Eisenhower Ave  
Alexandria, VA 22333

Commander  
USA Log Mgmt Ctr  
ATTN: Proc Res Ofc  
Robert Launer  
Ft. Lee, VA 23801

James A. Lechner  
National Bureau of Standards  
Washington, DC 20234

Commander  
USAOTEA  
ATTN: DACS-TET-A  
Larry Leiby  
Ft. Belvoir, VA 22060

Director  
NSA-R 21  
Charles T. Lempke  
Ft. Meade, MD 20755

Gerald J. Lieberman  
Dept. of Operations Research  
Stanford University  
Stanford, CA 94305

Director  
National Security Agency  
ATTN: R51  
James R. Maar  
Ft. Meade, MD 20755

Dale Madden, HFP 30  
Food and Drug Admin  
5600 Fishersa Lane  
Rockville, MD 20852

Dr. William Mallios  
Braddock, Dunn & McDonald Svc Co  
C/O USA CDEC  
Ft. Ord, CA 93941

Dr. Clifford J. Maloney  
Food & Drug Admin  
8000 Rockville Pike  
Bethesda, MD 20014

Commander  
Picatinny Arsenal  
Bldg 92  
John Mardo  
Dover, NJ 07801

Commander  
Frankford Arsenal  
ATTN: SARFA-PCD-P  
Nicholas Marasco  
Philadelphia, PA 19137

Commander  
Harry Diamond Labs  
ATTN: HDL-WRF  
Egon Marx  
Washington, DC 20438

Beulah Mathis  
Internal Revenue Svc  
1201 E St NW  
Washington, DC 20004

James M. Maynard  
105 Brookside Ave  
Hershey, PA 17033

Commander  
USAOTEA  
ATTN: DACS-TED-M  
Fred K. McCoy  
Ft. Belvoir, VA 22060

US Army Security Agency  
ATTN: IARD-D  
Bruce J. McDonald  
Arlington, VA 22212

Commander  
TECOM  
ATTN: AMSTE-RA  
Richard M. McGauley  
Aberdeen Proving Ground, MD 21005

Commander  
USA Yuma Proving Ground  
ATTN: Math & Instr  
Thomas O. McIntire  
Yuma, AZ 85364

Commander  
TECOM  
ATTN: AMSTE-RA  
William BL McIntosh  
Aberdeen Proving Ground, MD 21005

Director  
Armed Forces Inst Pathology  
ATTN: I. McLean  
Washington, DC 20305

Director  
Army Research Inst  
ATTN: J. J. Mellinger  
1300 Wilson Blvd  
Arlington, VA 22209

Ronald G. Merritt  
Constr Engr Res Lab  
P. O. Box 4005  
Champaign, IL 61820

Director  
Army Research Inst  
ATTN: Mary Marion  
1300 Wilson Blvd  
Arlington, VA 22209

Commander  
USA MERDC  
ATTN: STES-FB-BF  
Genevieve Meyer  
Ft. Belvoir, VA 22060

Commander  
Rock Island Arsenal  
ATTN: SARRI-LE-R  
Vaughn Meehan  
Rock Island, IL 61201

Commander  
USAOTEA  
ATTN: DACS-TED-T  
Jerome Miller  
Ft. Belvoir, VA 22060

Mr. Nash Monsour  
Stat Res Div  
Census Bureau  
Washington, DC 20233

Director  
Ballistic Research Labs  
ATTN: J. Richard Moore  
Aberdeen Proving Ground, MD 21005

V. N. Murty  
Penn State Univ.  
Capitol Campus-RM E355  
Middletown, PA 17057

Mr. A. Musco  
Potomac Research Inc.  
7655 Old Springhouse Road  
McLean, VA 22101

Mary G. Natrella  
National Bureau of Standards  
Washington, DC 20234

Commander  
AMMRC  
ATTN: Donald Neal  
Watertown, MA 02172

Commander  
MASSTER  
ATTN: Dr. Charles Nystrom  
Ft. Hood, TX 76544

Ms. Donna L. Newman  
Internal Rev Ser  
1111 Constitution Ave NW  
Washington, DC 20024

Michael J. O'Brien  
NSA-DOD  
Ft. Meade, MD 20755

Michael W. O'Donnell, Jr.  
Dept. of Defense  
Ft. Meade, MD 20755

Naval Sea Sys Cmd  
ATTN: Beatrice S. Orleans  
Code C-03F  
Washington, DC 20262

Director  
USAMSAA  
ATTN: AMRSY-RW  
Harold C. Pasini, Jr.  
Aberdeen Proving Ground, MD 21005

Commander  
USA Electronics Command  
ATTN: AMSEL-VL-F (Avionics Lab)  
Charles A. Pleckaitis  
Ft. Monmouth, NJ 07703

Commander  
Harry Diamond Labs  
ATTN: H. W. Price  
Washington, DC 20438

Commander  
Watervliet Arsenal  
Benet Wpns Lab  
ATTN: Ronald L. Racicot  
Watervliet, NY 12189

Commander  
USAOTEA  
ATTN: DACS-TED-T  
Stephen C. Reynolds  
Ft. Belvoir, VA 22060

Joan R. Rosenblatt  
National Bureau of Standards  
Washington, DC 20234

Director  
US Army Natick Labs  
ATTN: E. W. Ross  
Natick, MA 01760

Arthur D. Salomon  
IRS PR:S:MS  
1201 E St NW  
Washington, DC 20004

Office of Naval Research  
ATTN: S. M. Selig  
Ballston Tower #1  
Arlington, VA 22217

Commander  
WSMR  
ATTN: ID-R  
William L. Shepherd  
WSMR, NM 88002

John Sjoberg (address on last page of list)

Commander  
MERDC  
ATTN: Tim Small  
Ft. Belvoir, VA 22060

Dr. Stephen Smeach  
Univ. of So. Fla  
Dept of Math  
Tampa, Fla 33620

Commander  
Edgewood Arsenal  
ATTN: SAREA-CL-PO  
Arthur K. Stuempfle  
Aberdeen Proving Ground, MD 21010

Captain Rolf Stutzmann  
Embassy of Switzerland  
2900 Cathedral Ave., NW  
Washington, DC 20008

Commander  
USAOTEA  
ATTN: DACS-TED  
Roy Schmidt  
Ft. Belvoir, VA 22060

Commander  
USAMERDC  
ATTN: NVL (J. Swistak)  
Ft. Belvoir, VA 22060

Director  
WRAMC  
ATTN: D. Tang  
Washington, DC 20012

Director  
Ballistic Research Labs  
ATTN: M.S. Taylor  
Aberdeen Proving Ground, MD 21005

Marlin A. Thomas  
NSWC  
Code KCM  
Dahlgren, BA 22448

Ramie H. Thompson  
The Franklin Institute  
20th and the Parkway  
Philadelphia, PA 19046

Robert M. Thrall  
Dept of Math Sci  
Rice Univ  
Houston, TX 77001

Naval Ship R&D Ctr  
Code 184.1  
Edward J. Timko  
Bethesda, MD 20084

Bruce E. Trumbo  
National Sci Found  
1800 G St NW  
Washington, Dc 20550

Prof. Chris P. Tsokos  
Univ of So Fla  
Dept of Math  
Tampa, Fla 33620

Commander  
USACAA (Dr. E. Virene)  
8120 Woodmont Avenue  
Bethesda, MD 20014

John Van Ryzen  
Math Res Ctr  
Univ. Wis-Madison  
Madison, WI 53706

Commander  
USAOTEA  
ATTN: DACS-TED-T  
Michael Volpe  
Ft. Belvoir, VA 22060

Kenneth T. Wallenius  
Math Dept  
Clemson Univ  
Clemson, SC 29631

Steve Webb  
McDonnell Douglas Corp  
5301 Bols Ave  
Huntington Beach, CA 92647

Commander  
USAMERDC  
ATTN: STSFB-HM  
Samuel Wehr  
Ft. Belvoir, VA 22060

Commander  
Frankford Arsenal  
ATTN: E. Weigand  
Philadelphia, PA 19137

Dr. M. A. Weinberger  
National Defence Orae  
Cartier Sq MSB  
Ottawa, Ontario, Canada

Ms. Gertrude Weintraub  
Ammo Dev & Eng Directorate  
Picatinny Arsenal  
Dover, NJ 07801

Commander  
USA Tecom  
ATTN: AMSTE-RA  
Larry West  
Aberdeen Proving Ground, MD 21005

Commander  
Frankford Arsenal  
ATTN: G. C. White  
Philadelphia, PA 19137

Commander  
USA Electronic Proving Ground  
ATTN: STEEP-MI-I  
John Bart Wilburn, Jr.  
Ft. Huachuca, AZ 85613

Director  
USAMSAA  
ATTN: RAM DIV  
Paul E. Williams  
Aberdeen Proving Ground, MD 21005

Commander  
USAOTEA  
ATTN: DACS-TET-A  
Lang Withers  
Ft. Belvoir, VA 22060

Commander  
USACAA  
ATTN: Agatha S. Wolman  
8120 Woodmont Ave  
Bethesda, MD 20014

Dr. William W. Wolman  
US Dept of Transportation  
Federal Highway Administration  
Washington, DC 20590

Commander  
USA Missile Command  
ATTN: AMSMI-RER  
James W. Wright  
Redstone Arsenal, AL 35809

Mrs. P. A. Young  
Department of Defense  
Ft. Meade, MD 20755

Commander  
USAOTEA  
ATTN: DACS-TET-A  
Thomas Zeberlein  
Ft. Belvoir, VA 22060

Mr. Theodore G. Zeh, Jr.  
OASD (INL)WR  
RM 2B 323  
Pentagon, Washington, DC 20301

Commander  
Frankford Arsenal  
ATTN: PDR-P  
E. L. Church  
Philadelphia, PA 19137

Dr. Edwin Inselman  
AMCRD-R  
US Army Materiel Command  
5001 Eisenhower Avenue  
Alexandria, VA 22333

Dr. John C. Sjoberg  
Office of the Deputy Chief  
of Staff for Logistics  
US Army Logistics Evaluation  
Agency  
New Cumberland Army Depot  
New Cumberland, PA 17070

Unclassified

SECURITY CLASSIFICATION OF THIS PAGE (When Data Entered)

REPORT DOCUMENTATION PAGE		READ INSTRUCTIONS BEFORE COMPLETING FORM
1. REPORT NUMBER	2. GOVT ACCESSION NO.	3. RECIPIENT'S CATALOG NUMBER
ARO Report 75-2		
4. TITLE (and Subtitle)		5. TYPE OF REPORT & PERIOD COVERED
PROCEEDINGS OF THE TWENTIETH CONFERENCE ON THE DESIGN OF EXPERIMENTS IN ARMY RESEARCH, DEVELOPMENT AND TESTING		Interim Technical Report
7. AUTHOR(s)		6. PERFORMING ORG. REPORT NUMBER
9. PERFORMING ORGANIZATION NAME AND ADDRESS		8. CONTRACT OR GRANT NUMBER(s)
11. CONTROLLING OFFICE NAME AND ADDRESS		10. PROGRAM ELEMENT, PROJECT, TASK AREA & WORK UNIT NUMBERS
Army Mathematics Steering Committee on Behalf of the Chief of Research and Development and Acquisition.		
14. MONITORING AGENCY NAME & ADDRESS (if different from Controlling Office)		12. REPORT DATE
Army Research Office AMXRO P. O. Box 12211 Research Triangle Park, N.C. 27709		June 1975
		13. NUMBER OF PAGES
		985
		15. SECURITY CLASS. (of this report)
		Unclassified
		15a. DECLASSIFICATION, DOWNGRADING SCHEDULE
16. DISTRIBUTION STATEMENT (of this Report)		
Approved for public release; distribution unlimited. The findings in this report are not to be construed as an official Department of the Army position, unless so designated by other authorized documents.		
17. DISTRIBUTION STATEMENT (of the abstract entered in Block 20, if different from Report)		
18. SUPPLEMENTARY NOTES		
This is a technical report resulting from the Twentieth Conference on the Design of Experiments in Army Research, Development and Testing. It contains most papers presented at that meeting. These treat various Army statistical and design problems.		
19. KEY WORDS (Continue on reverse side if necessary and identify by block number)		
contingency tables	discriminant functions	
random processes	forecasting	
electroexplosives	curve fitting	
Weibull distribution	sensitivity analysis	
decision theory	multivariant data analysis	
reliability	Markov chains	
Bayesian statistics	motor case rupture	
computer simulation	incomplete block designs	
buffers	order statistics	
air traffic	least squares	
covariance computer program	structure failures	
log Rayleigh distribution	nickelcadmium batteries	
volcanic eruptions	surface roughness	
optimization	ranking and selection procedures	